

# COATS®

## RC-45 A/E, RC-55 A/E

### Rim Clamp® Tire Changers

For servicing single piece automotive and most light truck tire/wheel assemblies.



Model RC-45



Model RC-55

See  
**RIM Safety** page iv  
★ **Operating  
Instructions**  
on page 4.

## Safety Instructions Set-up Instructions Operation Instructions Maintenance Instructions

READ these instructions before placing unit in service. KEEP these and other materials delivered with the unit in a binder near the machine for ease of reference by supervisors and operators.

**HENNESSY INDUSTRIES, INC.**

1601 J. P. Hennessy Drive, LaVergne, TN USA 37086 615/641-7533 800/688/6359 www.ammcoats.com  
HENNESSY INDUSTRIES INC. Manufacturer of AMMCO®, COATS® and BADA® Automotive Service Equipment and Tools.

Manual Part No.: 85609956 00  
Revision: 01/15

# Tire Specifications Diagram

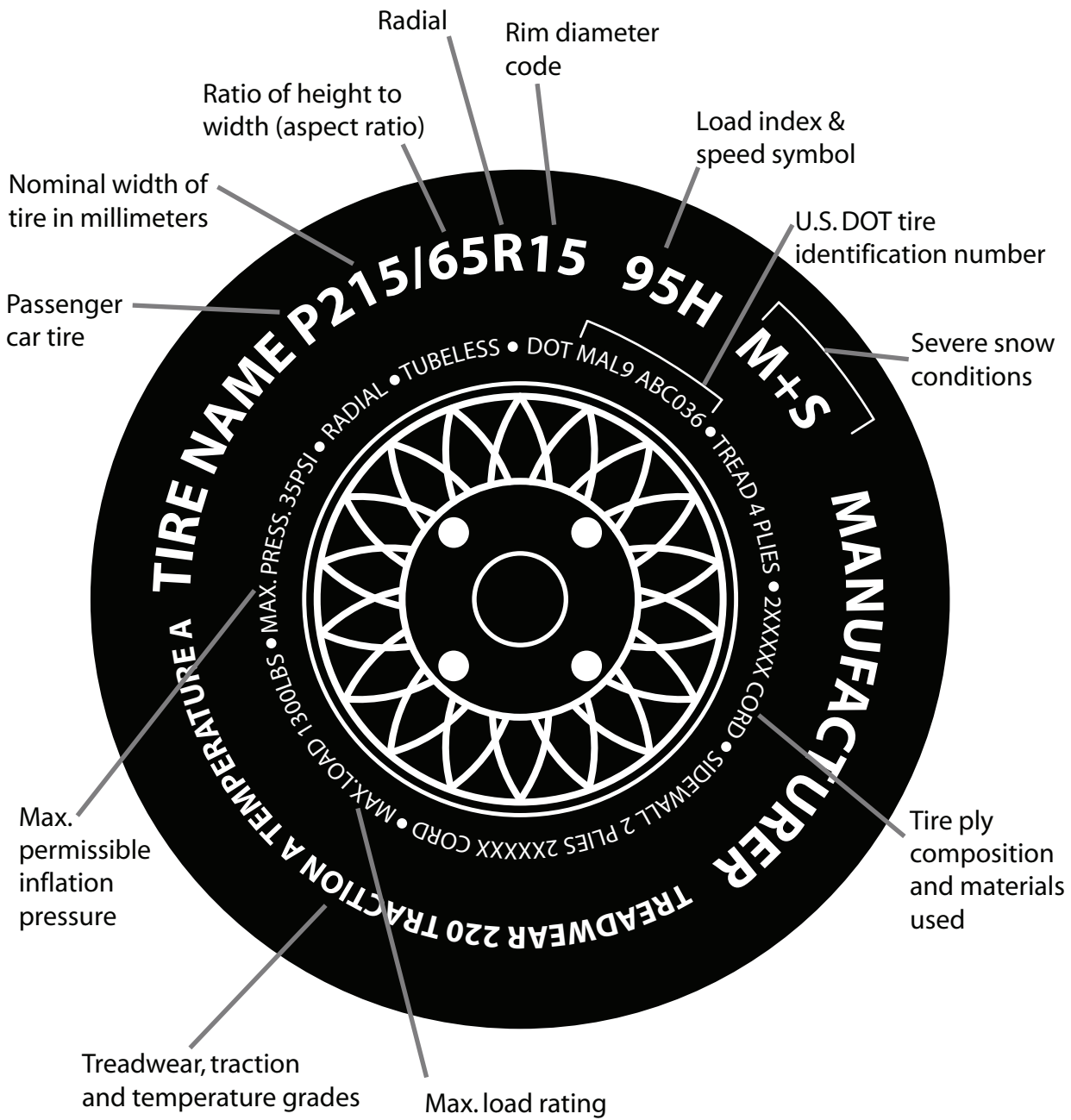

## Safety Instructions

### Owner's Responsibility

To maintain machine and user safety, the responsibility of the owner is to read and follow these instructions:

- Follow all installation instructions.
- Make sure installation conforms to all applicable Local, State, and Federal Codes, Rules, and Regulations; such as State, Federal OSHA Regulations and Electrical Codes.
- Carefully check the unit for correct initial function.
- Read and follow the safety instructions. Keep them readily available for machine operators.
- Make certain all operators are properly trained, know how to safely and correctly operate the unit, and are properly supervised.
- Allow unit operation only with all parts in place and operating safely.
- Carefully inspect the unit on a regular basis and perform all maintenance as required.
- Service and maintain the unit only with authorized or approved replacement parts.
- Keep all instructions permanently with the unit and all decals/labels/notices on the unit clean and visible.
- Do not override or bypass safety features.

### Operator Protective Equipment

Personal protective equipment helps make tire servicing safer. However, equipment does not take the place of safe operating practices. Always wear durable work clothing during tire service activity. Loose fitting clothing should be avoided. Tight fitting leather gloves are recommended to protect operator's hands when handling worn tires and wheels. Sturdy leather work shoes with steel toes and oil resistant soles should be used by tire service personnel to help prevent injury in typical shop activities. Eye protection is essential during tire service activity. Safety glasses with side shields, goggles, or face shields are acceptable. Back belts provide support during lifting activities and are also helpful in providing operator protection. Consideration should also be given to the use of hearing protection if tire service activity is performed in an enclosed area, or if noise levels are high.

## Definitions of Hazard Levels

Identify the hazard levels used in this manual with the following definitions and signal words:

### DANGER

Watch for this symbol:



It Means: Immediate hazards, which will result in severe personal injury or death.

### WARNING

Watch for this symbol:



It Means: Hazards or unsafe practices, which could result in severe personal injury or death.

### CAUTION

Watch for this symbol:



It Means: Hazards or unsafe practices, which may result in minor personal injury or product or property damage.



Watch for this symbol! It means BE ALERT! Your safety, or the safety of others, is involved!

## Safety Notices and Decals



**Failure to follow danger, warning, and caution instructions may lead to serious personal injury or death to operator or bystander or damage to property. Do not operate this machine until you read and understand all the dangers, warnings and cautions in this manual. For additional copies of either, or further information, contact:**

### **Hennessy Industries, Inc.**

1601 JP Hennessy Drive  
LaVergne, TN 37086  
(615) 641-7533 or (800) 688-6359  
[www.ammcoats.com](http://www.ammcoats.com)



### **For additional information contact:**

#### **Rubber Manufacturers Association**

1400 K Street N. W., Suite 900  
Washington, DC 20005  
(202) 682-4800  
[www.rma.org](http://www.rma.org)

#### **Tire Guides, Inc.**

The Tire Information Center  
1101-6 South Rogers Circle  
Boca Raton, FL 33487-2795  
(561) 997-9229  
[www.tireguides.com](http://www.tireguides.com)

## Remember R.I.M.

Three Simple Steps To Help Keep Shops Safe

### **READ INSPECT MOUNT**

R.I.M. is a training program developed by Hennessy Industries to help keep tire technicians safe. By following the basic principles of R.I.M., technicians can avoid situations that can cause catastrophic accidents like tire explosions.

**R.I.M.** stands for read, inspect, and mount:

**Read** the tire size on a new tire before mounting to make sure it is the proper size for the wheel.

**Inspect** the wheel for cracks, rust, and or other damage that could cause an unsafe situation.

**Mount** the tire safely, making sure not to put any part of your body over the tire during inflation.

The most serious of possible accidents is a tire explosion. This is often caused by a tire/rim mismatch.

If a tire explodes on a tire changer, pressure causes it to fly straight up at tremendous speed. If a technician is standing over the tire, he can be seriously injured or killed.

Hennessy's R.I.M. program allows the technician to avoid situations that can cause tire explosions and other accidents. The full program, including training videos, brochures, posters, and other materials, is available from Coats distributors nationwide.



*For more details, contact your Coats distributor or e-mail us.*

# Table of Contents

<b>Tire Specifications Diagram .....</b>	<b>ii</b>	<b>Custom and Special Wheels .....</b>	<b>18</b>
<b>Safety Instructions .....</b>	<b>iii</b>	Alloy Wheels.....	18
Owner's Responsibility.....	iii	European Performance Wheels (Asymmetrical Hump).....	18
Operator Protective Equipment .....	iii	Wheels with Low Pressure Warning Sensors.....	18
Definitions of Hazard Levels .....	iii	<b>Tube Type Tires .....</b>	<b>18</b>
Safety Notices and Decals .....	iv	Mounting.....	18
Remember R.I.M. ....	iv	Demounting.....	18
<b>Principal Operating Parts .....</b>	<b>2</b>	<b>Maintenance Instructions .....</b>	<b>19</b>
Know Your Unit.....	2	Duckhead® Mount/Demount Tool Cleaning .....	19
<b>Operating Instructions .....</b>	<b>4</b>	Duckhead® Mount/Demount Tool Adjustment .....	20
Tire Bead Loosening and Demounting.....	4	Pressure Limiter Maintenance .....	21
Tire Demounting Using Robo-Arm® LR.....	8	<b>Setup Instructions .....</b>	<b>22</b>
Tire Mounting.....	9	Location.....	22
Tire Mounting Using Robo-Arm® LR .....	11	Workspace Requirements.....	22
<b>Inflation .....</b>	<b>12</b>	Air Source.....	22
Bead Sealing .....	13	Electrical Source.....	22
Bead Seating .....	14	Floor Mounting.....	22
Inflation.....	15	<b>Notes .....</b>	<b>23</b>
<b>Stages of Inflation on a Conventional Tire and Rim 16</b>			
Bead Sealing .....	16		
Bead Seating .....	16		
Inflation.....	16		
<b>Mismatched Tires and Wheels.....</b>	<b>17</b>		

	 <span style="font-size: 24pt; font-weight: bold; margin-left: 10px;">NOTICE</span>
	<p style="text-align: center; margin: 0;"><b>Read entire manual before assembling, installing, operating, or servicing this equipment.</b></p>

## Principal Operating Parts

### Do It Now!

Now is a good time to contact product service to start warranty, otherwise warranty starts at time of shipment.

## Know Your Unit

Compare this illustration with the unit before placing it into service. Maximum performance and safety will be obtained only when all persons using the unit are fully trained in its parts and operation. Each user should learn the function and location, of all controls.

Prevent accidents and injuries by ensuring the unit is properly installed, operated and maintained.

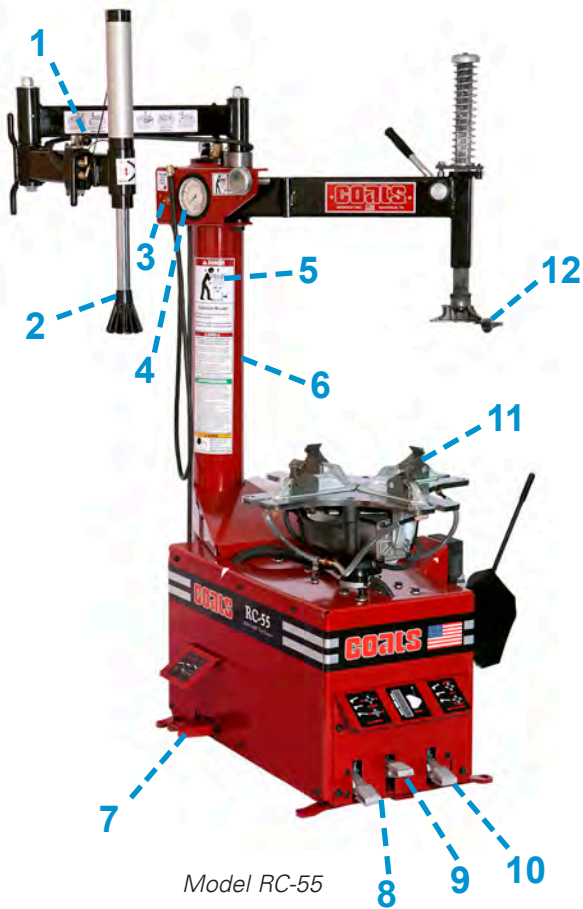

Model RC-55

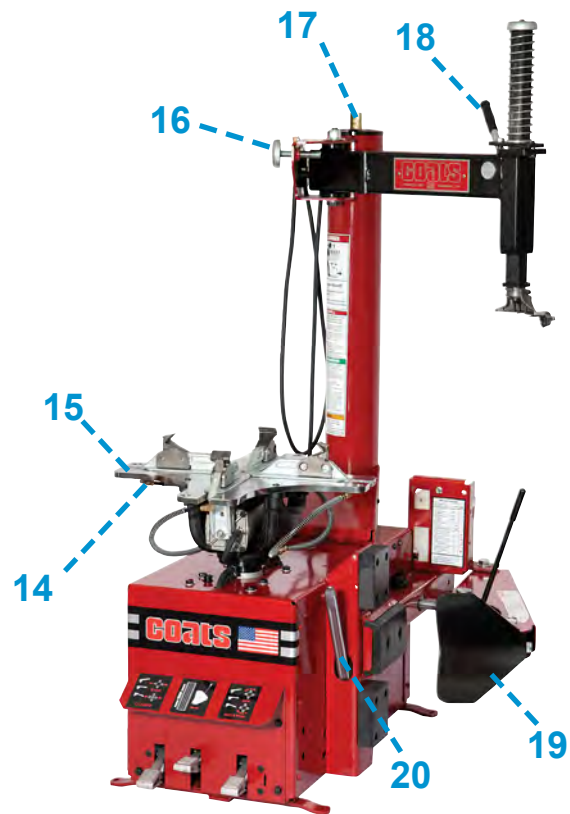

Model RC-45



Replace any damaged or missing safety decals. They are available from COATS, (800) 688-6359.

- 1 Robo-Arm™ LR Control Valve** — Controls vertical movement of robotic arm cylinder.
- 2 Robo-Arm™ LR Foot** — Provides extra leverage when mounting/demounting tires.
- 3 Release Valve** — Allows the manual release of air pressure from tire when clip-on chuck is attached to tire valve.
- 4 Air Inflation Gauge** — Registers tire pressure when clip-on chuck is attached to tire valve stem and inflation pedal is released.
- 5 Important Safety Decal** — Important safety information for the operator. DO NOT obstruct with tire stickers or other materials.
- 6 Tower** — Support for horizontal swing arm, also air storage tank.
- 7 Inflation Pedal** — Three-position pedal that allows inflation of tires through air hose and clip-on chuck.
- 8 Clamp Control Pedal** — Three-position pedal that opens and closes rim clamps.
- 9 Bead Loosener Handle** — Controls operation of bead loosener shoe.
- 10 Tabletop Rotation Pedal** — Three-position pedal that controls rotation of tabletop (forward, off, reverse).
- 11 Clamps** — Secures wheel to table top for tire changing. Position outward to allow outside clamping of wheels.
- 12 Duckhead® Mount/Demount Tool** — Mounts and demounts tire from wheel.
- 13 \*Lube Bottle** — Dispenser for rubber lubricant.
- 14 Bead Sealing Nozzles** — Expands tire sidewall to bead seat area of rim to seal tire to rim and allow inflation.
- 15 Tabletop** — Rotating chuck for tire changing.
- 16 Swing Arm Adjustment Knob** — Adjusts swing arm/vertical slide assembly for proper horizontal positioning of Duckhead mount/demount tool.
- 17 Pressure Safety Valve** — The high pressure safety valve is set to exhaust at line pressures above 185 PSI.
- 18 Vertical Slide Locking Handle** — Locks and unlocks vertical slide and sets correct vertical position to maintain head/wheel clearance.
- 19 Bead Loosener Shoe** — Pivoting shoe for loosening tire beads.
- 20 Bead Lifting Tool** — Used to lift and position tire bead correctly on Duckhead mount/demount tool.

\*Not Shown

## Operating Instructions

The unit must be properly operated and properly maintained to help avoid accidents that could damage the unit and injure the operator or bystanders. This section of the Operating Instructions manual review basic operations and use of controls. These instructions should be reviewed with all employees before they are allowed to work with the machine. Keep these instructions near the machine for easy reference.

### Tire Bead Loosening and Demounting



**This machine may operate differently from machines you have previously operated. Practice with a regular steel wheel and tire combination to familiarize yourself with the machine's operation and function.**

**A.** Remember to remove all weights from both sides of the wheel. Weights left on backside of wheel may cause the wheel to be clamped unlevelled. This may result in the Duckhead® mount/demount tool contacting the rim causing scratches. On alloy wheels, always rotate the wheel one turn after setting the mount/demount tool to insure proper wheel clamping.

**B.** Always review with the owner any nicks and scratches on expensive wheel and tire combinations prior to servicing.

**C.** Review the performance wheel section of this manual prior to servicing performance tire/wheel combinations.



**Loosening the beads on a partially or fully inflated tire is unsafe and causes excess movement and friction against the bumper pads and excessive wear on pivots. Deflate the tire completely to prolong the life of your machine.**

**1.** Deflate the tire completely by removing the valve core from the valve stem (figure 1). Be cautious and do not smoke as a *flammable gas could have been introduced into the tire at some time.*



Figure 1 - Remove Valve Core to Deflate Tire



**Tires are always installed and removed from the rim's narrow side.**

**D.** Always loosen the bead on the narrow side of the wheel's drop center first (tire removed in figure 2 for clarity).

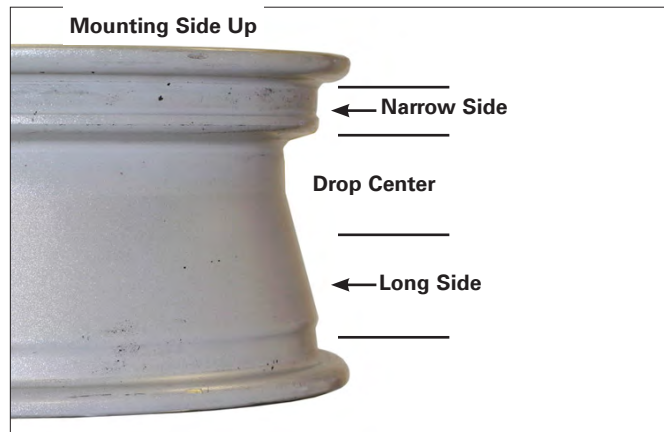

Figure 2 - Determine Narrow Side of Wheel

**E.** The clamps on the table top may extend beyond the table top itself. To avoid damaging the clamps, move them to their full inward position before positioning a tire for bead loosening.

**F.** Use extra care in positioning the bead loosener shoe on larger wheels/tires, and on alloy wheels. Make sure the shoe rests next to but not on the rim, and not on the tire sidewall.

**2.** Pull the bead loosener shoe away from the machine and roll wheel into position. The valve stem should be in the 2 o'clock position to accommodate a possible asymmetric safety hump type rim. Position the bead loosener shoe against the tire next to, but not on, the rim. Depress the bead loosener foot pedal to actuate the shoe and loosen the bead. It may be necessary to loosen the bead in multiple locations around the tire (figure 3).





Figure 3 - Position Tire and Bead Loosener Shoe with Valve Stem in 2 o'clock Position.

**3.** Turn wheel around and repeat loosening procedure on the other side of the wheel (figure 4). This should be the long side of the drop center (see Figure 2).



Figure 4 - Position Tire and Bead Loosener Shoe with Wheel Turned Around and Valve Stem in 2 o'clock Position.

**G.** It will be easier to outside clamp the wheel to the table top if the long side of the rim is loosened last.

**4.** Apply tire manufacturer's approved rubber lubricant liberally to entire circumference of both tire beads after loosening (figure 5).



Figure 5 - Apply Rubber Lubricant to Tire Beads

**5.** Determine the mounting side of the wheel. The mounting side is the narrow side of the drop center. See figure 2 for more information on the drop center.

**6.** Place tire/wheel assembly on table top with mounting side up (Figure 6).



Figure 6 - Place Tire/Wheel Assembly on Table Top



**Clamp control pedal must be in the full up or full down position (detent position) to maintain clamping force on wheel.**

**7.** Use the clamp control pedal to move the clamps inwards (push pedal down) or outward (lift pedal up). Clamp steel wheels from the inside (clamps push outwards against wheel). Engage the detent position (pedal in full up or full down position) to maintain clamped or unclamped pedal position.

Clamp steel wheels from the inside (clamps push outward against wheel). Clamp alloy and custom wheels from the outside (clamps push inwards against the outside rim edge). Refer to the Custom and Special Wheels section.

**8.** Move the swing arm into position. Pull the locking handle forward to release the slide. Push down on the top of the vertical slide to move the demount tool into contact with the rim edge. Push the locking handle back to lock the slide into place. As the slide is locked,

the mount/demount tool will move upward approximately 1/8 inch from the rim edge.

**Note:** On plastic mount/demount tool, the upward movement should be limited to 1/16-inch maximum.



Figure 7 - Position Mount/Demount Tool

**9.** The mount/demount tool roller should be in contact with the rim edge. Turn the swing arm adjusting knob to move the tool away from the rim 1/8 to 1/4 inch. On expensive and polished rims, it is recommended a plastic bootie (p/n 8183373) be used over the mount/demount tool roller.



Figure 8 - Adjust Swing Arm to Position Tool Roller

**10.** Check tool positioning. Mount/demount tool should be positioned with 1/8 to 3/16" clearance between the top of the rim edge and the bottom of the tool (with plastic mount/demount tool it is recommended the vertical clearance be limited to a maximum of 1/16-inch), and 1/8 to 1/4 inch clearance between the rim edge and the tool. This clearance will be maintained as long as the locking handle and adjustment knob are not changed. The operator may swing the arm out of the way and back into place again without needing to reposition the tool (when changing a set of the same wheels).

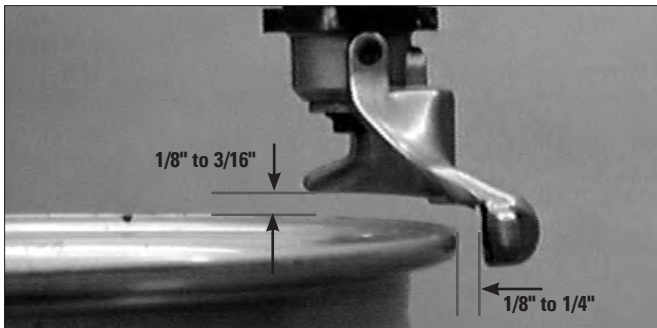

Figure 9 - Proper Mount/Demount Tool Position

**IMPORTANT:** The vertical tool clearance may change with machine use and should be inspected often. Failure to maintain the proper clearance may result in damage to the wheel rim and/or tire.

**11.** Insert the smooth curved end of the bead lifting tool over the forward end of the demount tool and below the top bead of the tire. Use your free hand to press down on the tire opposite the tool to help with tool insertion (Figure 10).



Figure 10 - Insert Bead Lifting Tool

**12.** Rotate the bead lifting tool down towards the wheel to lift the tire bead up and over the knob portion of the Duckhead® demount tool. The tool may be removed if desired (Figure 11).



Figure 11 - Lift Bead Over Demount Tool

**13.** Depress the table top pedal to rotate the wheel clockwise. The demount tool will guide the upper bead up and over the edge of the wheel.

**H.** Push down on the tire across from the demount tool during table top rotation to utilize the drop center area of the wheel. This reduces the tensional force on the bead during demount.

**14.** Lift and hold the tire at an angle so that the lower bead is resting in the drop center directly across from the demount tool, and is loose below the demount tool (Figure 12). Insert the smooth curved end of the bead lifting tool down over the forward end of the mount/demount tool and below the lower bead. Lift the bead up and over the knob on the demount tool (Figure 13).



Figure 12 - Demounting Lower Bead

**15.** Depress the table top pedal to rotate the wheel. The demount tool will guide the bead up and over the edge of the wheel. Continue rotation until lower bead is demounted.



Figure 13- Guide Bead Over Tool Head

**I.** With tube-type tires, demount the upper bead and remove the tube before demounting the lower bead.

**J.** Table top rotation can be stopped at any time by removing your foot from the pedal.

**K.** Normal table top rotation for demounting is clockwise. Depress the table top pedal to rotate this direction. To rotate the table top counterclockwise, lift the pedal up with your toe.



**At times during the mounting and demounting procedure, the bead lifting tool may encounter resistance or come under load. Keep one hand firmly on the tool to avoid possible tool disconnect. Use the reversing feature to back out or jam ups.**

## Tire Demounting Using Robo-Arm® LR

**1.** Follow operating instructions for Tire Bead Loosening and Demounting on page 4, steps 1 through 10. And then proceed as follows:

**2.** Starting with the Duckhead® demount tool at the proper rim edge position, place the Robo-Arm LR foot in front of the demount tool to depress the tire sidewall downward; providing clearance (figure 14). Now turn the swing arm adjusting knob to increase the horizontal distance between the demount tool and the wheel an additional 1/16 to 1/8 inch.



Figure 14 - Robo-Arm LR Foot Depressing Sidewall of Tire

**3.** Lubricate upper tire bead liberally.

**4.** Now place the Robo-Arm LR foot opposite the demount tool to push down on tire to allow bead to utilize the drop center area of the rim and allow easier bead lift over demount tool knob. Insert the smooth curved end of the bead lifting tool over the forward end of the demount tool and below the top bead of the tire (figures 15 & 16). Also note the valve stem position to the demount tool (figure 17).



Figure 15 - Insert Bead Lifting Tool

**5.** Hold bead lifting tool in this position (figure 16). Depress the table top rotation pedal momentarily to jog the wheel a short distance. Check the wheel and tire to verify that operation is not causing damage. The bead lifting tool can usually be removed after jogging the wheel a short distance. Continue to jog the wheel to allow the tire sidewall to flex as it crosses the rim edge. Continue short rotations until top bead is completely demounted.



Figure 16 - Lift Bead Over Demount Tool

**6.** Pay close attention to the valve stem location, and position it behind the demount tool when starting the lower bead demount procedure (Figure 17) to prevent damage to the TPMS (Tire Pressure Monitoring System) sensor.



Figure 17 - Position Valve Stem Behind Demount Tool Tail

**7.** Complete the lower bead demount procedure by following steps 14 and 15 of the Tire Bead Loosening and Demounting section on page 7.

## Tire Mounting

This information must be read and followed carefully to prevent accidents and injuries during mounting.



Mounting a mismatched tire and wheel will cause an explosion before it bead seats during inflation. Attempts to force a bead seat, by increasing air pressure, on mismatched tires and wheels will cause the tire to violently explode, causing serious personal injury or death to operator and/or bystanders if standing over tire and wheel.



Check tire and wheel carefully before mounting. Make sure the tire bead diameter and wheel diameter match exactly. Consult the tire manufacturer's recommendations, Tire Guide and/or Rubber Manufacturer's Association for approved rim widths for tire sizes.



Never mount a damaged tire. Never mount a tire on a rusty or damaged wheel. Used tires may have bead and/or tread damage. Used rims may have flange damage where the tire/rim was run down the road on a flat tire. Run-flat tires are not meant to be reused! Damaged tires and/or wheels may explode.



When in doubt do not mount. Never mount a tire and wheel handed to you by anyone without checking both tire and wheel for damage and to be certain the sizes match. Used tires may have road hazard damage or mount/demount damage, inspect carefully. Do not let untrained persons operate tire changer and keep bystanders out of service area.



Forcing the tire onto the rim can cause bead damage. If you damage the tire bead during mounting, STOP!, remove tire and mark it as damaged. Do not mount a damaged tire.

**1.** Before any mounting, inspect tire for damage and verify size match between tire and wheel (Figure 18).



Figure 18 - Verify Size Match Between Tire and Wheel

**2.** Inspect wheel closely for damage. Clean the wheel and remove any light corrosion or rubber residue (Figure 19). Do not attempt to service a heavily corroded wheel, damaged wheel, or bent wheel.



Figure 19 - Inspect and Clean the Wheel

**3.** Inspect valve stem and replace if necessary. Next lubricate tire beads liberally with tire manufacturer's approved rubber lubricant (Figure 20).



Figure 20 - Lubricate Tire Beads Liberally

**4.** Place tire over wheel and move swing arm into position making sure the valve stem is at the 9 o'clock position in front of bead lock. Position tire so that lower bead is above the rear extension of the mount/demount tool and below the front knob (figures 21 & 22).



Figure 21 - Position Tire Against Duckhead® Mount Tool

**5.** Depress table top pedal and rotate the wheel to mount lower bead. Use drop center of wheel by forcing down on tire just ahead of the mounting tool, and follow as tire rotates (figure 22). Rotate table top until lower bead is mounted.



Figure 22 - Mounting Lower Bead

**6.** For top bead installation, rotate the table top until the valve stem is directly across from the mount tool. Lift the top bead up and over the rear of the mount tool. With your left hand press down on the tire between the mount tool and the valve stem to hold the tire in the drop center. Depress table top pedal and rotate tire until bead is mounted. Be careful to ensure bead stays in the rim drop center in the area ahead of Duckhead mount/demount tool (figure 22).



Figure 22- Mounting Top Bead

**L.** If table top rotation stalls, reverse the table top momentarily until tire bead is again loose on the wheel. Reposition tire on Duckhead mount tool, make sure bead is correctly positioned in drop center of the wheel; then attempt mounting again.

**M.** For low profile or stiff sidewall tires, it may be advantageous to use the bead lifting tool to initially hold the upper bead down in the drop center.

**N.** For tube type tires, mount lower bead first, move swing arm out, install tube, and then mount upper

**O.** For some tire installations, it may be helpful to rotate the wheel in short steps and apply extra lubricant to mount the top bead.

## Tire Mounting Using Robo-Arm® LR

**1.** Follow the Tire Mounting procedure beginning on page 9, steps 1 through 5. And then proceed as follows:

**2.** For top bead installation, rotate the table top until the valve stem is 90 degrees clockwise in front of the mount tool. Lift the top bead up and over the rear of the mount tool. Using the Robo-Arm LR, press down on the tire between the mount tool and the valve stem to hold the tire in the drop center. Depress table top pedal and rotate tire until bead is mounted. Be careful to ensure bead stays in the rim drop center in the area ahead of the Duckhead mount tool (figure 23).



Figure 23 - Mount Top Bead Using Robo-Arm LR

**3.** On extremely tight tire and wheel combinations, it may be necessary to use the bottom of the Robo-Arm LR foot to flip the tire bead over rim flange (Figure 24)



Figure 24 - Use Bottom of Robo-Arm LR Foot to Flip Bead Over Rim Flange

## Inflation

Tire inflation is performed in three steps: **BEAD SEAL, BEAD SEAT, and INFLATION**. These steps are explained in detail. Read the explanation of each step and understand them thoroughly before proceeding.



Tire failure under pressure is hazardous. This tire changer Will Not Restrain Exploding Tires, rims or other related equipment. Inspect tire and wheel carefully for match, wear, damage, or defects before mounting. Always use approved tire bead lubricant during mounting and inflation.



The clip-on chuck allows the operator to keep hands and entire body back from inflating tire. The chuck must be an open/freeflow style with all parts in proper working order.



Check for proper inflation gauge operation. Accurate pressure readings are important to safe tire inflation. Refer to the Operating Maintenance section of this manual for instructions.



If the rim has been clamped from the outside for tire mounting, release the clamps, lift the tire, and move the clamps to the center of the table top.



If the wheel/tire has a diameter larger than 14-inches and is difficult to bead seal, the clamps should be moved to the center of the table top for the bead seal operation.

The inflation pedal, located at the center of the left side of the machine, controls the flow of air through the inflation hose, and has three positions.

○. The clip-on chuck on the end of the hose should always be an open/freeflow style with all parts in proper working order.

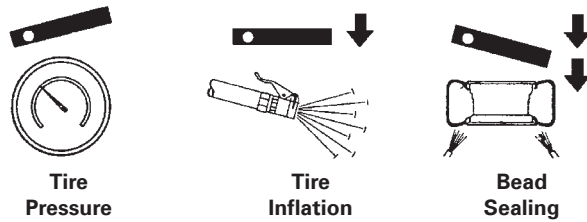

**Inflation Pedal Positions**

**Position 1 - Tire Pressure** – With the inflation hose attached to the tire valve and the pedal in this position, the air gauge will register the air pressure in the tire. Whenever your foot is removed from the pedal, it will return to this position.

**Position 2 - Tire Inflation** – This is the first activated position. With the inflation hose attached to the tire valve and the pedal in this position, line pressure is allowed to flow through the valve system and into the tire for inflation. Correct tire pressure is not indicated on the gauge in this position.

**Position 3 - Bead Sealing** – This is the second and last activated position. With the inflation hose attached to the tire valve and the pedal in this position, line pressure is allowed to flow through the valve and to the air-plate bead seal jets on the tabletop for bead sealing.

1. If the rim has been clamped from the outside for tire mounting, release the clamps, lift the tire, and move the clamps to the center of the tabletop.

The inflation pedal, located at the center of the left side of the machine, controls the flow of air through the inflation hose.

**Note the Pedal Positions** (See Diagram)



## **WARNING**

**Use of bead sealing jets without a tire in place can cause dirt and debris to be blown into the air with enough force to injure operator and/or bystander. Do not use the bead sealing control position to inflate a tire.**

**P.** This unit is equipped with a pressure limiter to assist the operator with proper tire inflation. When the inflation pedal is held in position 2, the pressure limiter cycles the machine between position 2 (inflation) and position 1 (at rest, no airflow to tire). This cycling helps to prevent over inflation of the tire. Tires can still be over inflated and explode with the use of this pressure limiter if all of the instructions in this manual are not followed completely. The pressure limiter will keep most car and light truck tires from inflating beyond 60 PSI (smaller tires may reach higher pressures). It is the operator's responsibility to follow all instructions and to control inflation pressure as specified in these instructions. Check the function of the pressure limiter regularly and maintain it according to the instructions provided in this manual for safe and proper operation. Do not tamper with or attempt to adjust the pressure limiter. Tires requiring inflation beyond 60 PSI should be inflated in a safety cage.

## **Bead Sealing**

**1.** Position valve stem in front of operator and connect the inflation hose with the clip-on chuck. Hold tire up against upper edge of the wheel. Be sure tire's top bead does not cover the bottom of the valve stem (figure 25).



*Figure 25 - Lift Tire Upwards for Bead Sealing*

**2.** Depress inflation pedal to position 2 and hold about one second to begin air flow through tire valve, then depress pedal to position 3 and hold briefly — less than one full second. The blast of air from the jets will expand tire and seal the beads.

**3.** Release the inflation pedal and allow it to return to position 1. Verify that both beads are completely sealed to the wheel. Repeat these steps if beads have not sealed. It may be necessary to wait a few seconds for the air storage tank pressure to recover before attempting again.

**R.** If tire and wheel are properly lubricated and operator cannot achieve bead seal after three or four attempts, the valve core may be removed from the valve stem to allow more air flow into the tire to assist with bead seal. After bead seal is achieved, remove the clip-on chuck and reinstall the valve core. Reattach the clip-on chuck after core is installed.

## Bead Seating



**NEVER** exceed 40 PSI to seat beads while using this tire changer. If more than 40 PSI is permitted by tire manufacturer, **ALWAYS** use safety cage and clip-on chuck. **NEVER** exceed recommended pressure after seating beads. **ALWAYS** keep hands and entire body back from inflating tire.

An exploding tire, wheel, or bead seating equipment may propel upward and outward with sufficient force to cause serious injury or death to operator or bystander.



Check tire pressure frequently. If operator is unable to obtain Bead Seat, something is wrong. Deflate tire completely, inspect tire and wheel, correct any problems found, relubricate both tire beads, and reattempt Bead Seal and Seat procedures. Follow all safety instructions in this manual and on machine.

**1.** Once tire pressure is indicated on the air gauge (inflation pedal in position 1; foot removed from pedal), continue to inject air into the tire (inflation pedal position 2) in short intervals. Check the pressure frequently. Stand back during bead seat. Keep hands, arms, and entire body away from tire during this procedure (figure 26).



Figure 26 - Stand Back during Bead Seat

## Inflation



**NEVER** exceed tire manufacturer's recommended air pressure. Tires can explode, especially if inflated beyond these limits. Use clip-on air chuck, keep hands, arms and entire body back from inflating tire. Avoid distraction during inflation. Check tire pressure frequently to avoid over inflation. Excessive pressure can cause tires to explode, causing serious injury or death to operator or bystander.

1. Make sure both beads are seated. When both beads are seated, the tire is ready for inflation.
2. Replace the valve core if it was removed.
3. Depress the inflation pedal to position 2 to inflate the tire. The pressure limiter will cycle the air flow as described earlier. On most tires, the pressure limiter will cease air flow at approximately 60 PSI. On smaller volume tires the pressure may be higher.
4. Release air pressure from tire by pressing the manual release valve button (inflation hose must be attached to the valve stem, Figure 19). Never add or adjust tire pressure using an air hose without a clip-on air chuck and in-line valve. Do not use a hand-held style chuck (figure 20).
5. **Important:** When inflating automotive, light truck, and motorcycle (ATV see note 6) tires that require more than 60 PSI, always use a safety cage and air hose with a clip-on air chuck and in-line valve. The air hose must have enough length between the chuck and the operation/in-line valve to allow the operator to stand outside the trajectory.

**6. ATV Tire Inflation:** ATV tire inflation is unique in that the bead seat pressure allowed is more than the operating pressure. ALWAYS follow the tire manufacturer's information on inflation. This information can be printed on the sidewall, on the tire sticker, or from the manufacturer.



Figure 27 - Location of Manual Release Valve

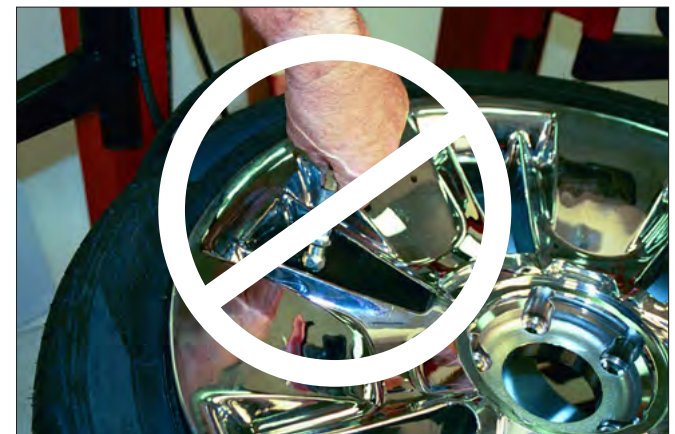

Figure 28 - Do Not Use a Hand-held Style Air Chuck

**! DANGER**

**Explosion Hazard**

**Never exceed 40 PSI while seating beads. If you use more than 40 PSI always use safety cage.**

**Remember R.I.M.**

(see page iv and back cover)

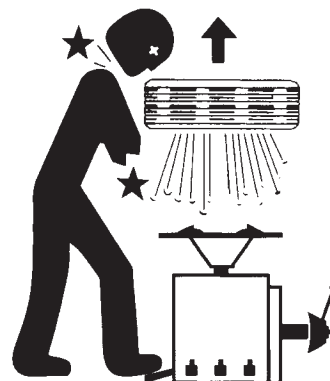

**! DANGER**

**Explosion Hazard**  
**Never inflate tire above manufacturer's recommended pressure after bead is seated.**

## Stages of Inflation on a Conventional Tire and Rim

Review these descriptions and diagrams carefully. Refer to them as necessary during bead sealing, bead seating, and inflation to verify that you are proceeding properly and safely.

### Bead Sealing

Bead sealing is the process of capturing air pressure between the tire and the rim. The tire will usually contain about 1/2 to 2 PSI at initial bead seal.

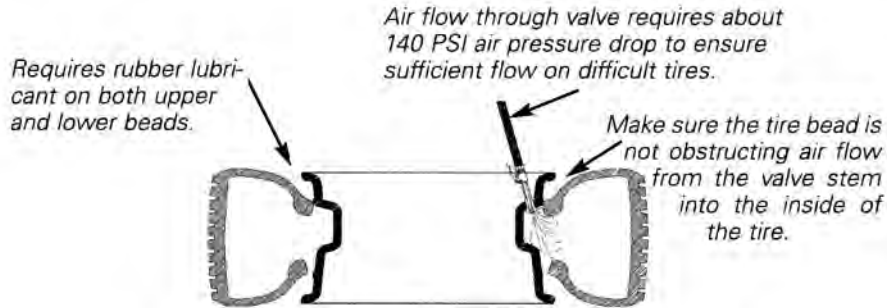

### Bead Seating

Bead seating usually occurs on the long tapered side of the wheel first and the shorter side last. Bead seating will usually require at least 7 PSI in the tire. 40 PSI is the maximum safe pressure at this stage regardless of tire operating pressure. For tires requiring more than 40 PSI to bead seat use safety cage.

Most European import cars and many aftermarket alloy wheels are very tight and can be difficult to bead seat. Also note that asymmetrical hump and run-flat tires are extremely difficult to bead seat. Follow tire manufacturer's recommended procedure for bead seating.

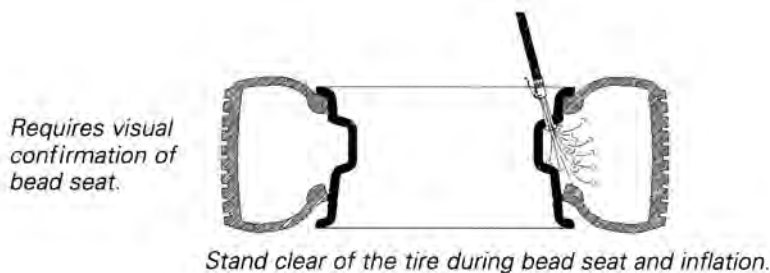

### Inflation

After the beads are seated, the tire is ready to be inflated. Do not inflate the tire above the manufacturer's recommended pressure as stamped on the tire sidewall. The typical inflation pressure for automobile tires is between 24 and 45 PSI. Light truck inflation pressure typically covers a wider range.

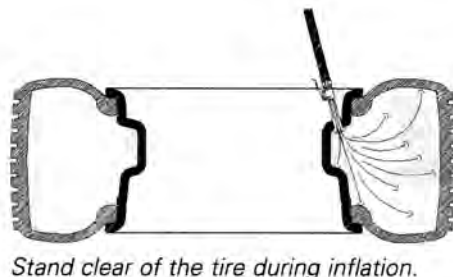

## Mismatched Tires and Wheels

Never mount and inflate mis-matched tires and wheels.

**! DANGER**

Mismatched tire and wheel combinations will explode, if you attempt to force a bead seat, causing personal injury or death to operator and/or bystanders.

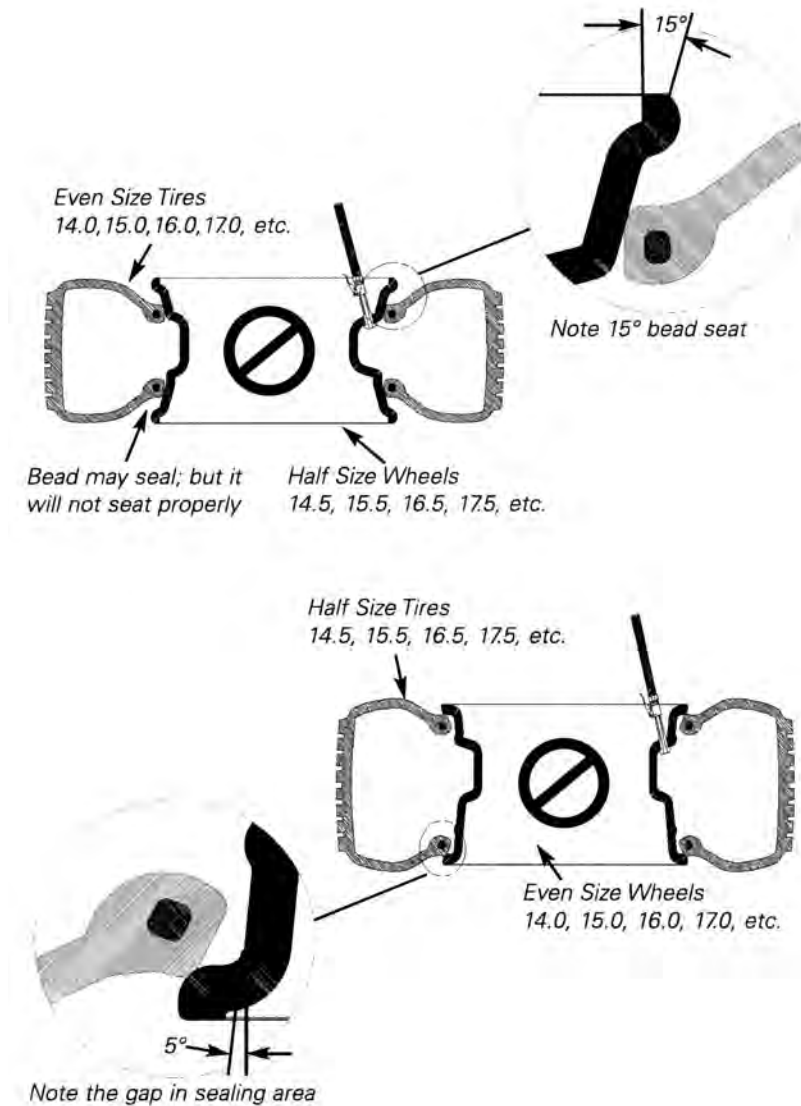

## Custom and Special Wheels



Only tire technicians with experience and training on custom wheels should attempt to service expensive custom alloy or aluminum wheels and high-performance low-profile tires.

### Alloy Wheels

Some manufacturers offer wheels with little or no drop center. These are not DOT approved. The tire or wheel - or both - can be damaged and the tire could explode under pressure, resulting in serious injury or death. Do not mount/demount this type of wheel (figure 38).

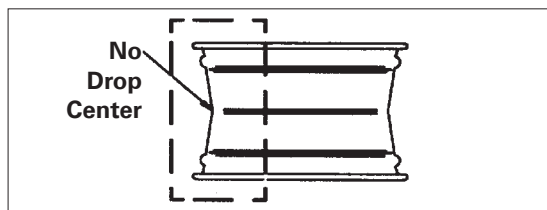

Figure 38 - No Drop Center

### European Performance Wheels (Asymmetrical Hump)

Some European wheels have very large humps except near the valve hole. On these wheels, the beads should be loosened at the valve hole on both the upper and lower sides first (figure 39).

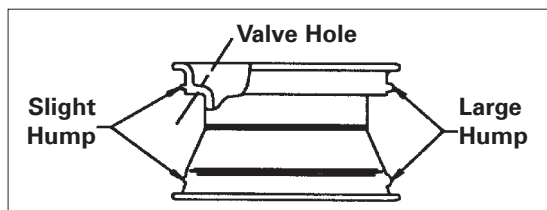

Figure 39 - Asymmetrical Hump on European Wheels

### Wheels with Low Pressure Warning Sensors

Performance wheels on some vehicles (including Corvette, BMW, Lamborghini Diablo) have a pressure sensor strapped to the rim opposite the valve hole. On these wheels, the beads should be loosened at the valve hole on both upper and lower sides first (figure 40).

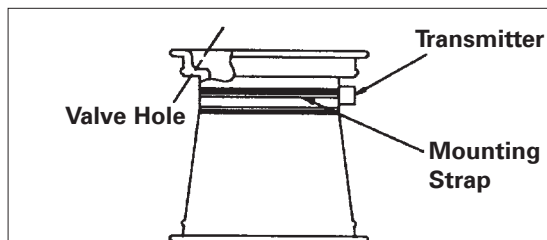

Figure 40 - Wheels with Low Pressure Sensor

## Tube Type Tires

### Mounting

1. Avoid pinching or forcing the tube.
2. Apply rubber lubricant to the beads of the tire.
3. Mount the bottom bead.
4. Round out the tube with a small amount of air.
5. Apply rubber lubricant to the tube.
6. Insert the tube into the tire.
7. Mount the top bead.

### Demounting

1. After tire beads are loosened, lubricate the beads and rim liberally.
2. Position demount tool and bead lifting tool as described in steps 8 through 12 on pages 5 and 6. Depress table top pedal and rotate only a short distance at a time. This allows you to stop the process should the tube get pinched.
3. After upper bead is demounted, remove tube and demount lower bead.



### Do It Now

Make sure the instruction and warning decal is clean and clearly visible to operator.



## Maintenance Instructions

Read and follow all the maintenance instructions provided in this manual to keep the machine in good operating condition. Refer to the other materials received with the unit and to the service bulletins from the manufacturer for additional instructions on proper maintenance and service. Regular inspections and proper maintenance are essential to preventing accidents and injuries.



**Before making any inspection, adjustment, or repair, disconnect the power source and block out all moving parts to prevent injury.**



**Keep the machine and the immediate work area clean. Do not use compressed air to remove dirt and debris from the machine. Foreign material may be propelled into the air and into operator or bystander causing personal injury.**



**Wear protective clothing, equipment and eye protection when making any adjustments or repairs to the machine.**

- A.** The vertical slide should be cleaned with a vaporizing solvent and then lubricated with chassis grease once a month.
- B.** Check the adjustment of the Duckhead mount/demount tool once a month. See instructions this page.
- C.** The table top, clamps, steel Duckhead mount/demount tool, and other working surfaces should be cleaned with a vaporizing solvent every month.
- D.** Inspect clamps. If using Max-Grip™ clamps then replace any worn or damaged grips and covers or if using other clamps then remove metal chips and dirt from the serrations with a wire brush every month.

**E.** Check the tire pressure gauge function daily, and check the accuracy monthly. Use a pressurized tire and a high quality stick-type pressure gauge. If necessary, adjust the dial of the machine gauge. If the gauge is defective, replace it immediately (part number 8107985). Contact COATS at (615) 641-7533. Check function of the pressure limiter weekly. Always reinstall the lens after adjusting the gauge.

**F.** Make sure all fasteners are securely tightened.

**G.** Make certain that all guards and covers are in place.

**H.** Check for worn, damaged or missing parts including grips and protective covers. Replace them before allowing the unit to be used.

**I.** On a daily basis, inspect the unit and check to be certain that all systems are operating normally. Detailed inspection and testing procedures are specified for various components at regular intervals. Set up a chart and assign responsibility for these items.



**Replace any damaged or missing safety decals. They are available from COATS, (800) 688-6359.**

**Important:** These instructions will help you service the unit. Instructions are for a person with some mechanical ability and training. No attempt has been made to describe all basic steps. For example, how to loosen or tighten fasteners. Also basic procedures such as cycling systems and checking operation of the equipment are not fully described since they are known to anyone who does mechanical and service work. Do not attempt to perform work beyond your ability or at which you have no experience. If you need assistance, call an authorized service center or contact COATS directly, (800) 688-6359.

### Duckhead® Mount/Demount Tool Cleaning

Clean dirt and debris from the mount/demount tool roller with small screw driver or pick.



## Duckhead® Mount/Demount Tool Adjustment

### To Adjust Tool Head Lift

Shoulder screw (ref.1) sets the tool head lift for metal Duckhead mount/demount tools – no adjustment required. Place shim 85606345 on screw if using a plastic Duckhead mount/demount tool.

### To Adjust Lock Tightness

With lock handle unlocked, loosen jam nut (ref. 3) and adjust pin (ref. 4) until a slight firmness is obtained, then tighten jam nut and check. Also recheck tool head lift at this time.

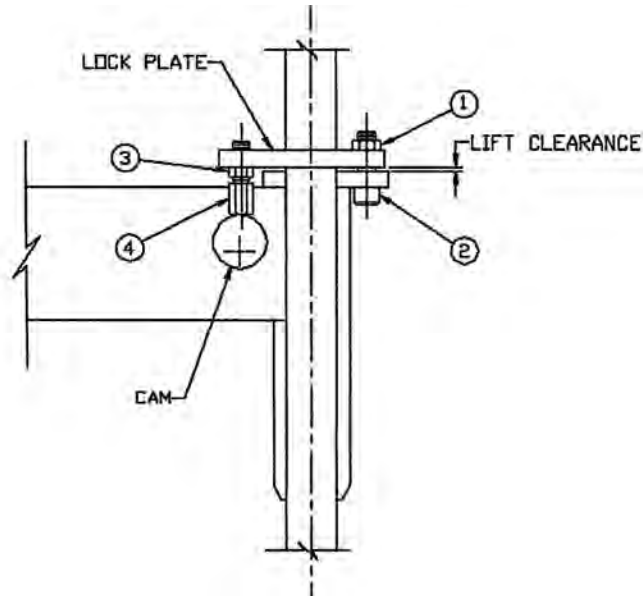

## Oil Injector Maintenance

The oil injector (on units so equipped) typically require annual service. The oil level in the oil reservoir tank should be checked regularly.

Add oil to oil reservoir tank when fluid level is a quarter full or below. Remove cap from the oil reservoir tank and add Chevron Regal® R & O 32 oil to full line (air tool oil is an acceptable substitute). Replace cap and clean up any spilled oil.

**Important:** An air lock will form if the hose between the reservoir and injector is ever empty of oil. In this case, after filling the reservoir tank, the line must be bled of air at the injector connection as follows:

1. Disconnect all power sources, both air and electricity inputs. Allow any stored air in the reservoir to escape by depressing the inflate pedal.
2. Remove the side panel and locate the oil injector.
3. Prime the oil injector.

### a. Oil Injector With Bleeder Screw

Loosen bleeder screw until oil drips from screw and all air is relieved from the oil line hose. Retighten the bleeder screw.

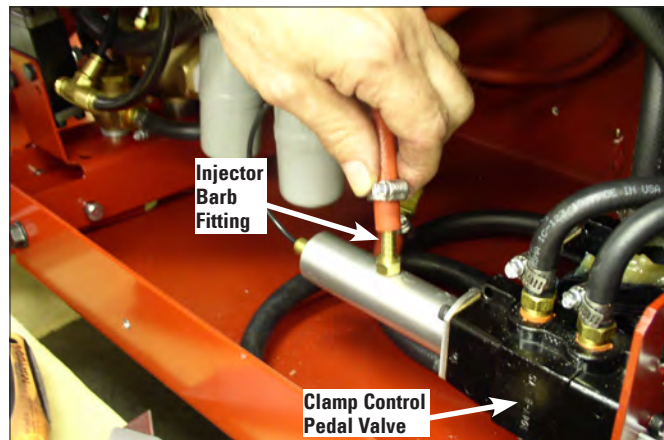

### b. Oil Injector Without Bleeder Screw

Remove the oil line hose from the injector barb fitting. Allow air to escape from the hose by lowering the hose end below level of reservoir until oil is present. Drip oil into hose barb fitting on injector until barb fitting is full. Reinstall oil line hose onto oil injector barb fitting.

4. Reconnect air/electric sources and cycle the clamp control pedal a few times checking for oil and air leaks.
5. Test the machine for full function before returning the machine to operation.
6. Monitor oil consumption to ensure oil is being used in system.



## Pressure Limiter Maintenance



**Operating a tire changer with a defective, improperly adjusted, or by-passed pressure limiter could cause an operator to accidentally over pressurize a tire, resulting in a tire explosion with severe injury or death to the operator or bystanders.**

**Always be sure that the pressure limiter is present and is operating properly.**



**Never inflate tire above manufacturer's recommended pressure after bead is seated. Pressure limiter is set at 60 PSI. Any required inflation above 60 PSI should be performed in an inflation chamber/safety cage or securely mounted on the vehicle if an inflation chamber is not available. A tire explosion may cause personal injury or death to operator or bystanders.**

The pressure limiter helps prevent inflation of standard size or larger tires or tubes beyond 60 PSI to minimize risk of explosion. This device is for the safety of the operator and bystanders. Proper operation of the pressure limiter is essential to safe operation of the machine.

Check operation of the pressure limiter as shown and described below at least monthly:

- 1.** Remove tires and/or wheels from the machine.
- 2.** Connect the inflation hose to an empty service tank with a pressure gauge (should read 0). Use a certified tank with at least 200 PSI pressure rating.
- 3.** Depress inflation pedal to position 1 to start airflow through the hose and into the tank. Maintain a steady pressure for constant flow.

**4.** Watch the rising pressure on the tank gauge and the gauge on the machine. Machine gauge should cycle between check and inflation pressures while tank gauge climbs steadily. As tank pressure reaches 60 PSI, the pressure limiter should stop the airflow automatically. Both gauges should read 60 PSI  $\pm$  5 PSI.

**5.** Release inflation pedal. Check manual release valve function by pressing the button and releasing pressure from the tank until it reaches 50 PSI. Disconnect inflation hose, and release air inside tank.

**6.** Replace pressure limiter if it fails to cycle properly during inflation, if it fails to shut air supply off at 60 PSI, or if it malfunctions in any other way. Do not operate machine with a faulty pressure limiter.

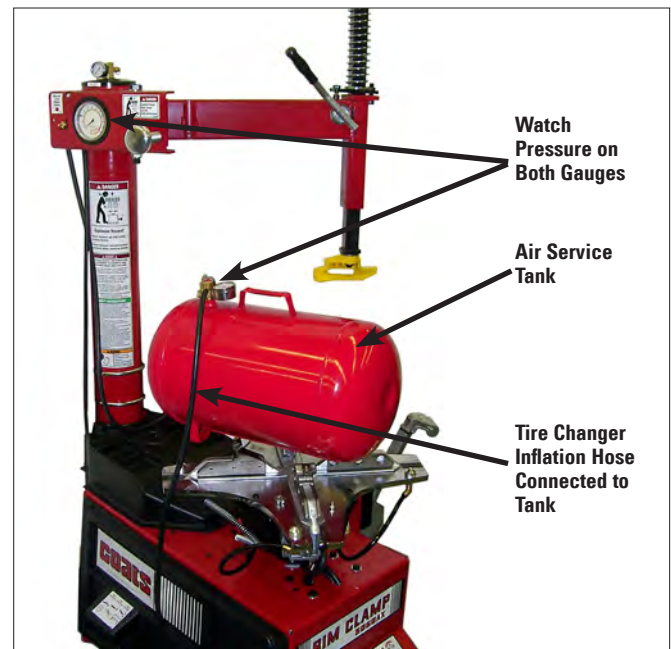

## Setup Instructions



**Proper unit installation is necessary for safe use and efficient operation. Proper installation also helps protect the unit from damage and makes service easier. Always place safety poster and instructions near the unit.**

### Location

Select a location using the drawings below. The area should provide the operator with enough space to use the equipment in a safe manner. The area selected should be well lit, easy to clean and should be away from oil, grease, brake lathe chips, etc. Avoid areas where bystanders and customers may be present.

### Workspace Requirements

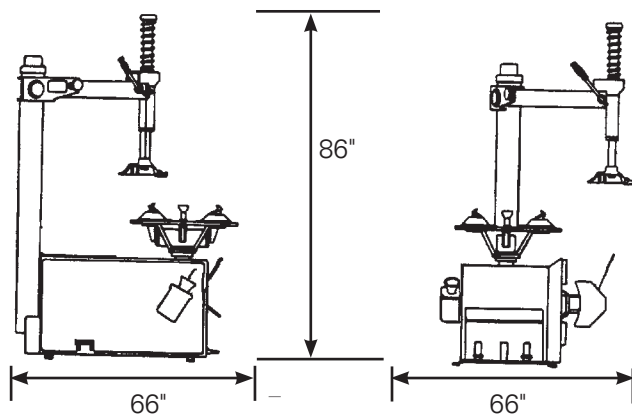

### Air Source

The all-air models require a 14 to 15 CFM air source at 150 PSI. The air/electric models require a 5 CFM air source at 150 PSI. The operating pressure range for all models is between 110 PSI and 175 PSI at the machine.

The unit is furnished with a 1/4" pipe thread male fitting for easy connection. This connection is located on the right side of the rear of the machine. A 1/4" ID hose (or pipe) for connection to the machine is satisfactory. Sufficient air pressure ensures good performance.

### Electrical Source

Electrical models require power as follows:

15 amp, 115V, 60 Hz, 1 PH electrical circuit

Refer to the caution decal that is located by the unit's power cord.

Refer to the serial tag located on the lower part of the machine for specific electrical requirements for the unit. Have a licensed electrical technician perform any necessary changes to the power source before plugging in the unit. The electrical source must have a solid connection (less than 1 ohm) between ground and building ground.

### Floor Mounting

As Hennessy can not be certain of the environment and conditions of the locations where the equipment will be installed, it is recommended that the safety manager review the shop floor conditions and local regulatory practices to determine if bolting of the equipment to the shop floor is necessary or advisable.

## Notes

# ONE WORD FOR SAFETY

## R.I.M.

### READ INSPECT MOUNT

#### READ...

Mounting and inflating the wrong size tire can get you hurt. *Read* the size on the tire and make sure it matches the rim. Be especially careful about putting a smaller tire on a larger rim, such as a 16-inch tire on a 16.5-inch rim.

Inflation of a mismatched tire and rim can cause an explosion.

#### INSPECT...

Before you put any tire on a rim, *inspect* the rim for rust, tough spots, bent edges, or cracks that could prevent the tire from seating right. If you spot any of these problems, don't mount the tire until the rim has been checked by your shop foreman.

*Inspect* the tire for bead damage.

#### MOUNT...

Once you've made sure the tire is OK and the right size and the rim is OK, *mount* the tire safely. NEVER, ever lean over the tire when you're inflating it. If a tire does explode, it will go straight up. You don't want to be over the tire if that happens. Also, never over-inflate the tire, even if the bead doesn't seat. Never inflate over 40 PSI. If the tire hasn't seated, something is wrong. Deflate the tire and check it and the rim again. If it doesn't work the second time, try another tire.

### BE CAREFUL OF THESE SITUATIONS:

- 1. Damaged Bead or Beads.**
- 2. Rusty Wheels.**  
(particularly in the bead seat area)
- 3. Bent or Cracked Wheels.**
- 4 A. Mismatched.**  
(A mis-match of a 16-inch tire to a 16.5-inch rim causing an explosion)
- 4 B. Mismatched.**  
(16.5-inch tire on a 16-inch rim)
- 5. Walk-In Tire and Rim.**
- 6. Back Injuries.**
- 7. Hand or Finger Injuries.**  
(Hands or fingers too close to inflating tire or bead seats which may cause injury.)
- 8. Standing Clear.**  
(Never put any part of your body over the tire changer during inflation.)
- 9. Beads will not Seat at 40 PSI.**
- 10. Improper Inflation.**

**Remember R.I.M. (Read, Inspect, Mount) for every tire.**



**FAILURE TO READ AND FOLLOW ALL WARNINGS AND INSTRUCTIONS IN THIS MANUAL CAN LEAD TO SERIOUS PERSONAL INJURY OR DEATH TO OPERATOR OR BYSTANDER.**

THE OWNER IS RESPONSIBLE FOR MAINTAINING THE OPERATION INSTRUCTIONS AND DECALS FOR OPERATOR REFERENCE. FOR ADDITIONAL COPIES, CONTACT THE COATS® COMPANY, 1601 J.P. HENNESSY DRIVE, LAVERGNE, TENNESSEE, 37086 - (800) 688-6359.

**TIRE FAILURE UNDER PRESSURE IS HAZARDOUS! This tire changer Will Not Restrain Exploding Tires, rims or other related equipment.**

**TIRES CAN EXPLODE, ESPECIALLY IF INFLATED BEYOND SPECIFIED LIMITS. DO NOT EXCEED TIRE MANUFACTURERS RECOMMENDED AIR PRESSURE.**

**AN EXPLODING TIRE, RIM, OR BEAD SEATING EQUIPMENT MAY PROPEL UPWARD AND OUTWARD WITH SUFFICIENT ENERGY TO CAUSE SERIOUS INJURY OR DEATH TO OPERATOR AND/OR BYSTANDERS.**