



For servicing single piece automotive and most light truck tire/wheel assemblies.



Parts Identification

READ these instructions before placing unit in service. KEEP these and other materials delivered with the unit in a binder near the machine for ease of reference by supervisors and operators.

HENNESSY INDUSTRIES, INC.

1601 J. P. Hennessy Drive, LaVergne, TN USA 37086-3565 615/641-7533 800/688/6359 www.ammcoats.com
HENNESSY INDUSTRIES INC. Manufacturer of AMMCO®, COATS® and BADA® Automotive Service Equipment and Tools.

Manual Part No.: 85606720 05
Revision: 9/13

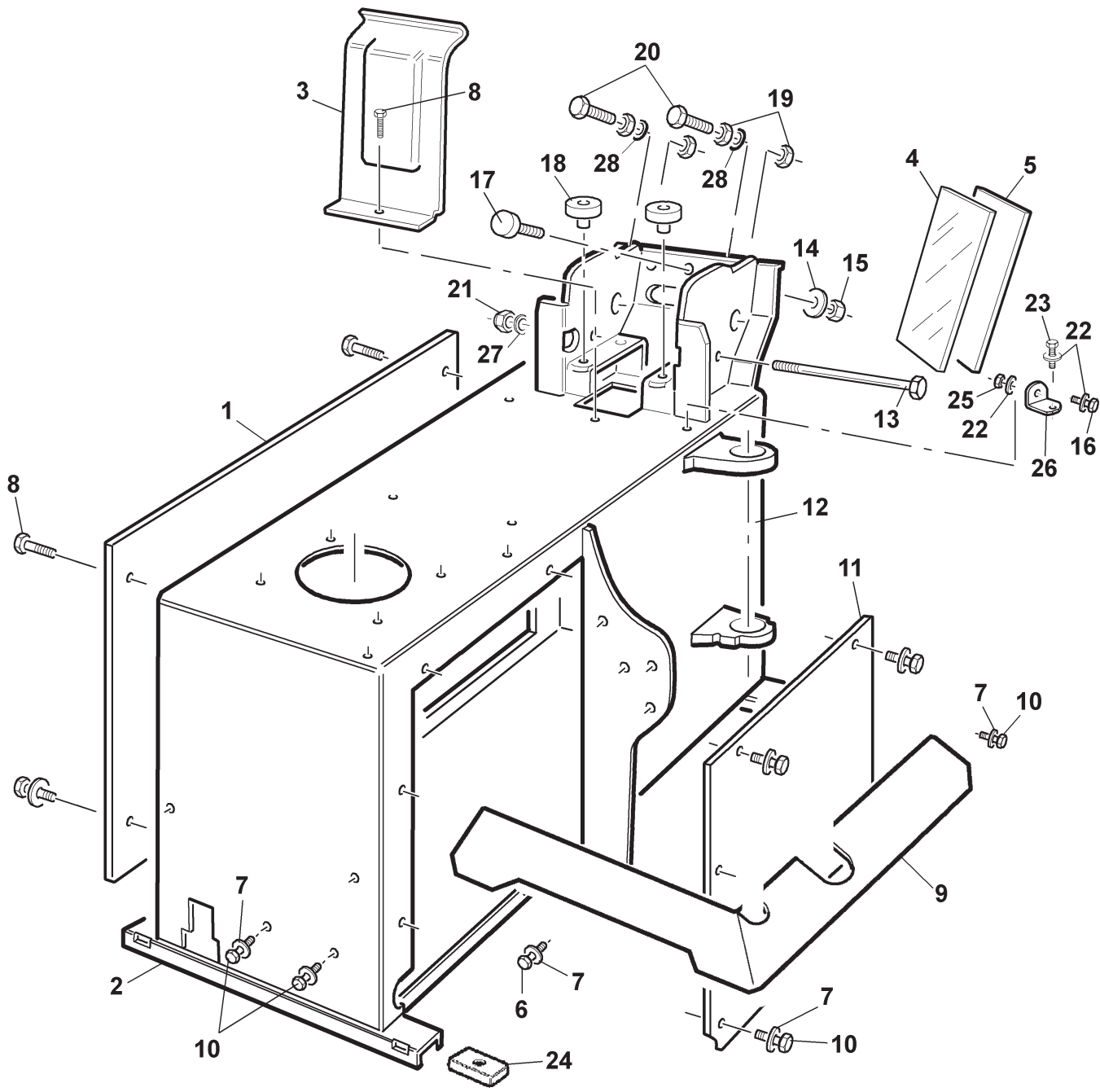

Ref.	Code	Description
1	6119318	LEFT SIDE PANEL
2	6119265	COMPLETE FRAME
3	3012450	ARM FRONT COVER - ABS
4	3019970	MIRROR 80 x 190 mm
5	3019745	MIRROR SUPPORT
6	4398723	SCREW 6x12
7	4399998	WASHER 6 (6,4x12x1,6)
8	4393749	KNURLED SCREW TCEI M 6x20
9	6119415	PEDAL COVER
10	4399300	SCREW 6x12
11	6119319	RIGHT SIDE PANEL
12	6119267	METAL PLATE
13	4395109	SCREW 12x190
14	4399829	WASHER 8 (8,4x16x1,5)
15	4398862	NUT M8
16	4399827	SCREW 8x20
17	4296213	SHOCK-ABSORBER 30/20 M8
18	3019914	SPACER
19	4399967	NUT M10
20	4399786	SCREW 10x30
21	4399865	SELF-LOCKING NUT M12
22	4399829	WASHER 8 (8,4x16x1,5)
23	4399946	SCREW 8x16
24	3002099	PLASTIC FOOT
25	4399900	SELF-LOCKING NUT M8
26	3019921	MIRROR SUPPORT PLATE
27	4398637	WASHER D.12x21x2,5 UNI1750
28	4398662	GROWER WASHER D.10

When ordering **always** specify the **serial number** shown on the data plate placed on the machine. Please also **always** specify the **reference** and the **code** number of the spares you required.

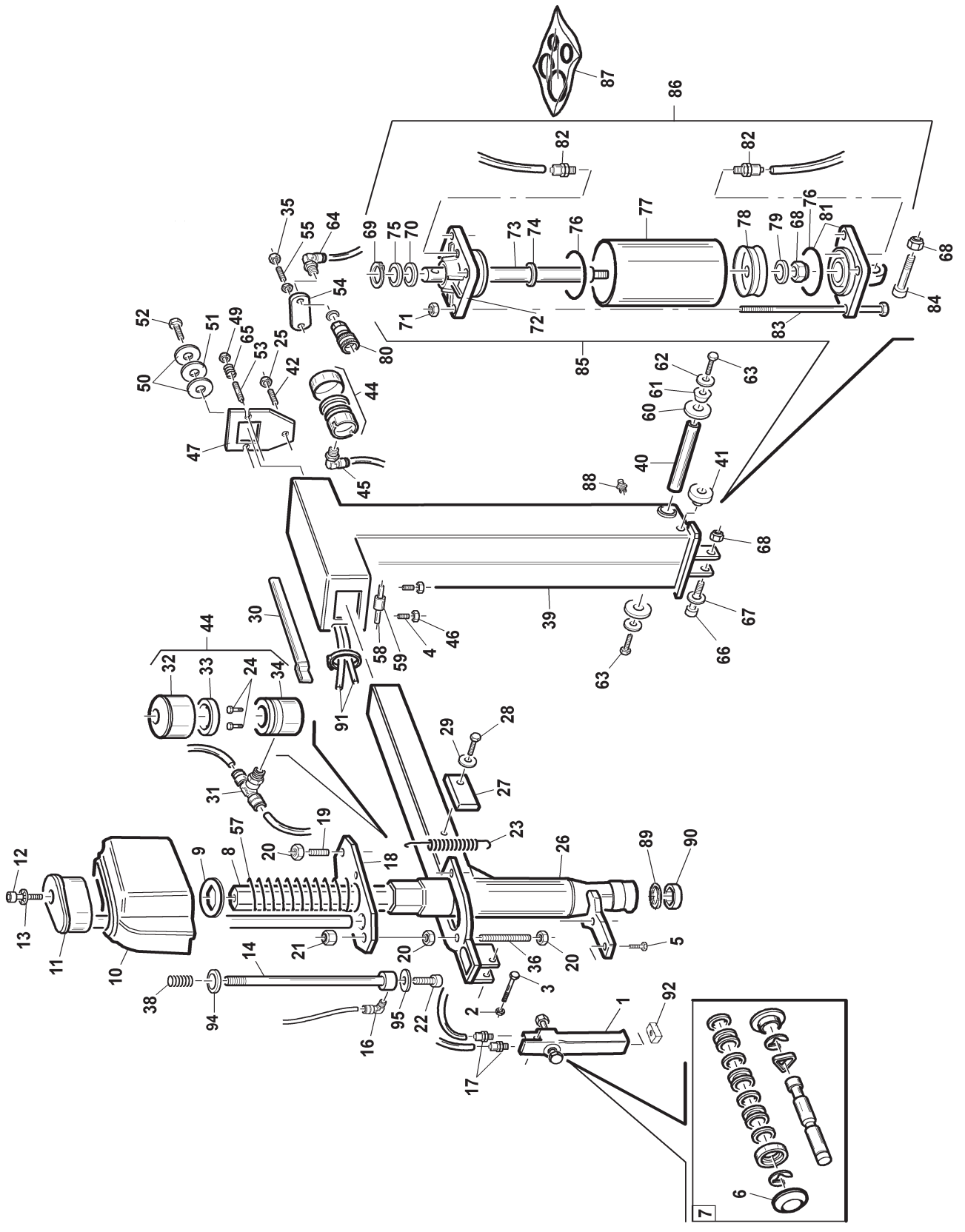

Ref.	Code	Description
45	4197741	UNION 1/8"
46	4399967	NUT M10
47	3035280	HORIZ.ARM LOCKING PLATE
67	4399981	WASHER 12 (13x24x2,5)
68	4399865	SELF-LOCKING NUT M12
69	3199599	SEEGER RING D.30
70	4398146	STEEL SHIM 24x30x1
71	4397678	FLANGED NUT M8
72	3015024	FLANGE
73	3002624	CYLINDER ROD L=309
74	4398146	O-RING 20,29x2,62
75	3199601	SCRAPER
76	4298822	O-RING D.68,26x3,53
77	3008084	CYLINDER LINER L=135
78	4198856	PISTON D.75
79	4398753	WASHER D.12,5x30x3
80	4194089	QUICK UNION MOD.5053-1/8 F
81	3015023	FLANGE
82	4198954	QUICK UNION 1/8"
83	3008085	SPECIAL SCREW M8x160
84	4399539	SCREW 12x110
85	2008082	TILTING CYLINDER
86	2019556	TILTING CYLINDER UNIT
87	2004804	CYLINDER SEAL D.75
88	4399207	LUBRICATOR M6
89	3017974	SHOCK ABSORB. RING COVER
90	3002601	MOUNTING TOOL SHOCK ABSORBER
91	3031217	RILSAN HOSE 4x2,7 L=2850
92	3013355	HANDLE INSERT

Ref.	Code	Description
1	2012461	ROBOT CONTROL
2	4399895	SELF-LOCKING NUT M4
3	4399896	SCREW 4x35
4	4398762	SCREW 10x25
5	4399892	SCREW 6x20
6	3012721	CAP
7	2008335	ARM CONTROL SPARES
8	3008889	HEXAGONAL ARM D.41 L=856
9	3019471	WASHER
10	3012357	ARM FRAME
11	2008968	OUTER PIPE
12	4399133	SCREW 8x40
13	4399122	TOOTHED WASHER 8,4x15x0,8
14	2008969	INNER PIPE
16	4197718	UNION
17	4197743	UNION
18	3017071	ARM LOCK PLATE
19	4398284	SCREW 10x30
20	4399967	NUT M10
22	4398897	SCREW 5x20
23	3002273	SPRING
24	4399135	SCREW 6x35
25	4398498	NUT M16
26	6619483	HORIZONTAL ARM ASSY
27	3007935	SHOCK ABSORBER
28	4399827	SCREW 8x20
29	4399863	WASHER 8 (9x24x2)
30	3008915	PIPE GUIDE
31	4197740	QUICK UNION 1/8"
32	4299524	CYLINDER LINER D.60
33	4299522	SEALING RING
34	4299523	PISTON D.60
35	4399969	NUT M10
36	3012459	THREADED BAR M10 L=120
38	3002629	SPRING 13,5x28 F 2,TILT TOWER ASSY
40	3015981	ARTICULATION PIN
41	3014633	ARM SPACER
42	4393862	SCREW STEI 10x40 P.P. 5923
44	2099665	LOCKING CYLINDER

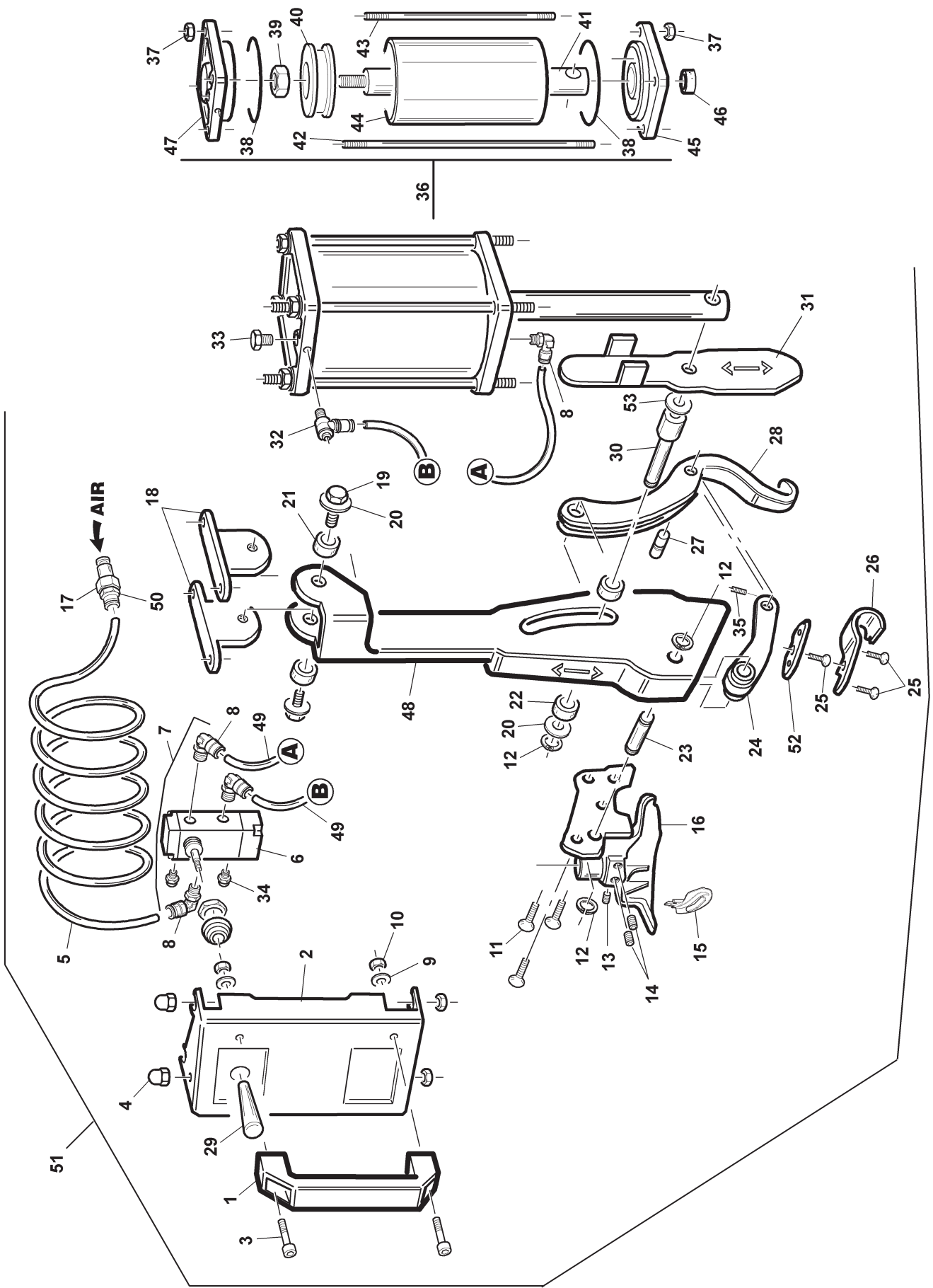

Ref.	Code	Description
1	4297851	HANDLE
2	7019215	VALVE BOX
3	4399954	SCREW 8x20
4	4395374	NUT M8
5	3030571	POLYUR. SPIRAL HOES 6x4 L=1500
6	4198285	5-WAY VALVE
7	2006996	VALVE
8	4198618	UNION 1/8"
9	4399829	WASHER 8 (8,4x16x1,5)
10	4399900	SELF-LOCKING NUT M8
11	4393957	SCREW TSPEI 10X12
12	4399864	SEEGER RING D.12
13	4395530	SCREW STEI 12x12 P.COPPA 5929
14	4395529	SCREW STEI 12x16 P.P.
15	3019305NE	BACK SLIDE
16	3019198	TOUCHLESS MOUNTING TOOL
17	4194088	QUICK UNION
18	3019202	CONNECTION PLATE
19	4399434	SCREW 12x20
20	4398637	WASHER D.12x21x2,5
21	3017334	BUSH 12/18/8,2
22	3017302	FERRULE 12/18/6,5
23	3019212	TOOL PIN
24	3019214	CONNECTING ROD
25	4393956	SCREW TSPEI 5X6
26	3019306NE	TOOL FRONT SLIDE
27	3019210	PIN
28	3019213	TOUCHLESS TOOL
29	3010284	KNOB D.14X45 M5
30	3019211	CYLINDER PIN
31	3019561	SUPPORT PLATE
32	4194004	UNION MR 41 6 M6 (90°-GIR)
33	4199161	PLUG 1/8"
34	4199610	SILENCER 1/8"

Ref.	Code	Description
35	4399957	SCREW 6x8
36	2031707	CYLINDER UNIT
37	4399976	NUT M8
38	4298822	O-RING D.68,26x3,53
39	4399865	SELF-LOCKING NUT M12
40	4198856	PISTON D.75
41	3031708	CYLINDER SHAFT
42	3019208	SPECIAL SCREW 8X1,25X180
43	3019204	SPECIAL SCREW TE M8X1,25X164
44	3031709	CYLINDER LINER L=129,5
45	3015024	FLANGE
46	3199601	SCRAPER
47	3019467	BACK FLANGE D.75 S.O. HOLE M6
48	7019199	TOOL HOLDER
49	3019959	ELASTOLAN HOSE 6x6 L=240
50	4198993	QUICK UNION 1/8"
51	9219907	472/09 KIT QX
52	3031595	THREADED TAB
53	4396878	STEEL SHIM 12x25x0,5

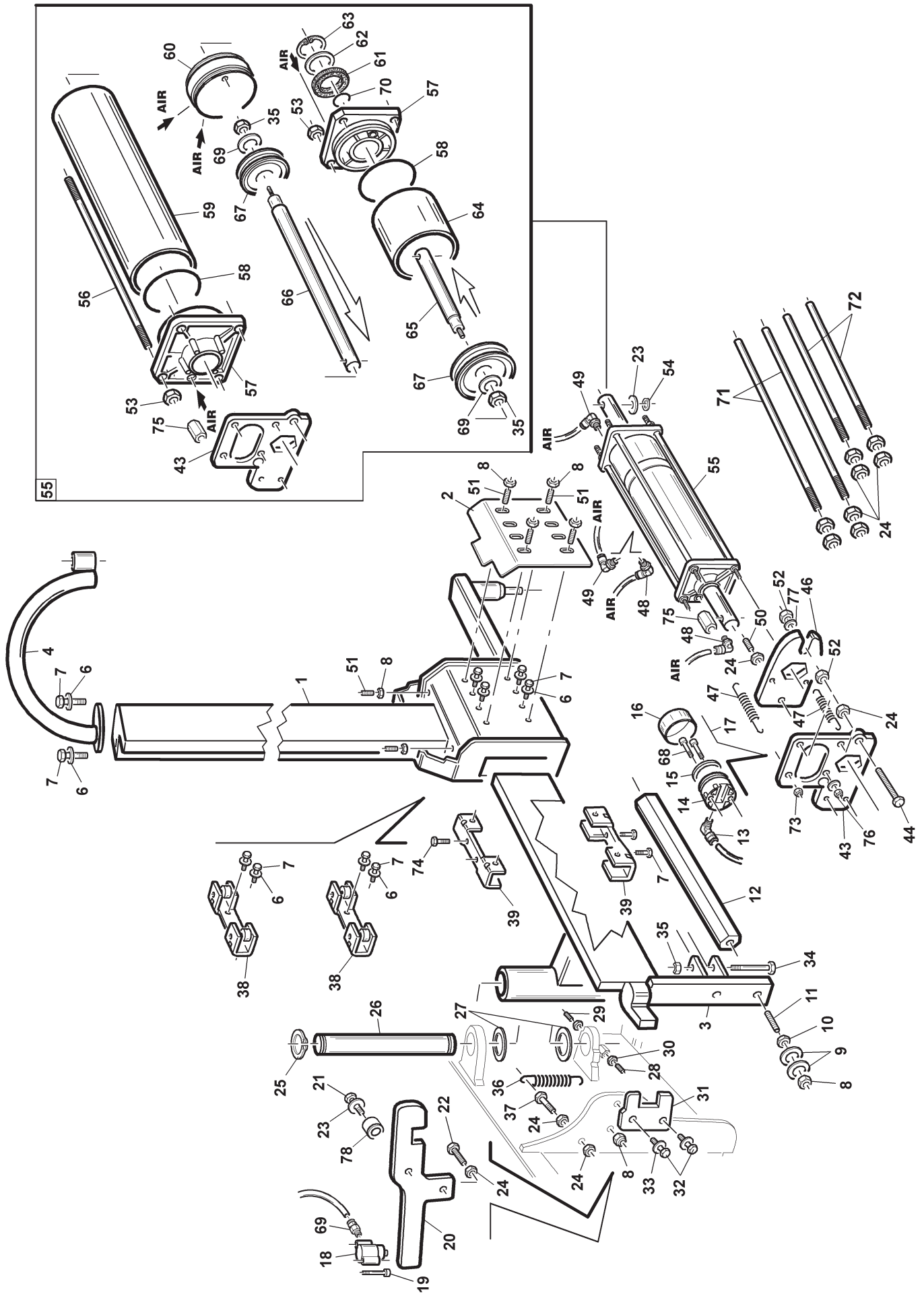

Ref.	Code	Description
1	7032816	HORIZ. CARRIAGE WITH GUIDE
2	6119414	VERTICAL GUIDE METAL SHEET
3	7032851	LOWER GUIDE
4	7019425	ARCH
6	4399829	WASHER 8 (8.4x16x1.5)
7	4399946	SCREW 8x16
8	4398657	NUT M12
9	4398659	BELLEVILLE WASHER 12.2x28x1.5
10	4395566	NUT M12
11	4398956	SCREW 12x60
12	3019351	LOWER HEX. BAR
13	4197741	UNION 1/8"
14	4299523	PISTON D.60
15	4299522	SEALING RING
16	4299524	CYLINDER LINER D.60
17	2019991	LOCKING CYLINDER UNIT
18	2019768	RELEASE CYLINDER UNIT
19	4399135	SCREW 6x35
20	3019311	CARRIAGE HOOK
21	4399982	SCREW 12x30
22	4399786	SCREW 10x30
23	4399981	WASHER 12 (13x24x2.5)
24	4399967	NUT M10
25	4398178	SEEGER RING D.40
26	3019400	GUIDE PIN
27	4399962	STEEL SHIM 65x40x0.5
28	4397766	SCREW 16x50
29	4397259	SCREW 16x40
30	4399295	NUT M16
31	3019312	FASTENING PLATE
32	4398635	SCREW 12x16
33	4398637	WASHER D.12x21x2.5
34	3000599	PIN M12 L=50
35	4399865	SELF-LOCKING NUT M12
36	3030115	RETURN SPRING
37	4399880	SCREW 10x40

Ref.	Code	Description
38	2031530	ROLLER HOLDER
39	2031529	ROLLER HOLDER
43	3032856	CYLINDER SUPPORT
44	3012459	THREADED BAR M10 L=120
45	6119395	CYLINDER GUARD
46	3019398	FASTENING PLATE
47	3002273	SPRING
48	4196214	UNION 1/8"
49	4197210	UNION 1/8"
50	4398284	SCREW 10x30
51	4393807	SCREW STEI 12x25 P.P.
52	4399971	SELF-LOCKING NUT M10
53	4399976	NUT M8
54	4399864	SEEGER RING D.12
55	2033110	CYLINDER D.75
56	3019412	SPECIAL SCREW
57	3015024	FLANGE
58	4298822	O-RING D.68.26x3.53
59	3019405	LONG CYLINDER LINER D.75
60	3019402	CYLINDER FLANGE
61	3199601	SCRAPER
62	4398146	STEEL SHIM 24x30x1
63	3199599	SEEGER RING D.30
64	3019403	SHORT CYLINDER LINER D.75
65	3019404	SHORT CYLINDER SHAFT
66	3019406	LONG CYLINDER SHAFT
67	4198856	PISTON D.75
68	4398620	SCREW 6x45
69	4398753	WASHER D.12.5x30x3
70	4299168	O-RING 20,29x2.62
71	3019762	UPPER ROD IRON
72	3033103	LOWER ROD IRON
73	4397678	FLANGED NUT M8
74	4396078	SCREW 8x14
75	4198921	STUD BOLT 1/8" H=16
76	4399893	SELF-LOCKING NUT M6
77	3002205	WASHER D.10.5x21x2
78	3019969	BUSH 12/18/10.5

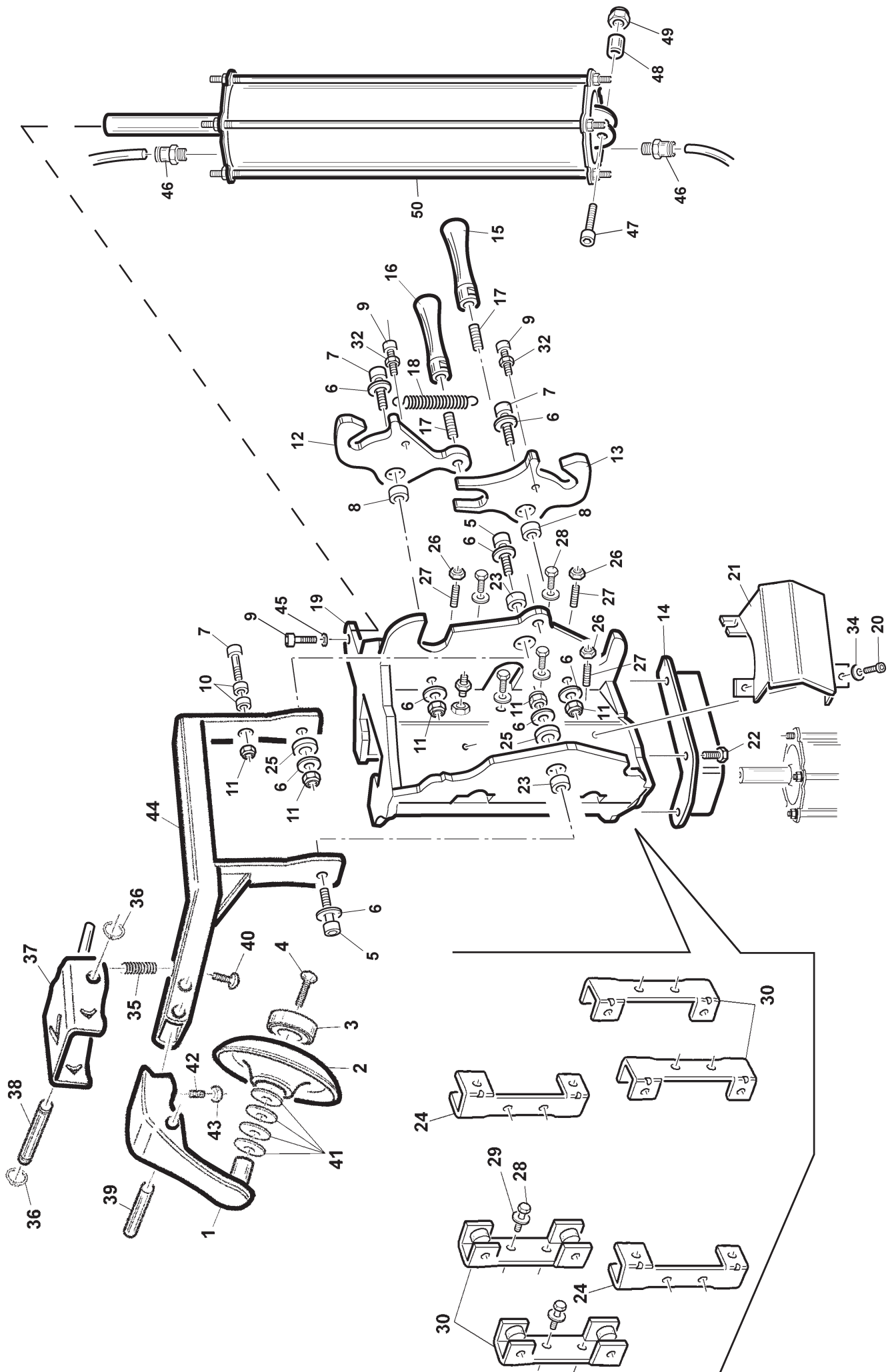

Ref.	Code	Description
1	7034671	DISK SUPPORT PLATE
2	3018464	DISC "S" D.150
3	4294264	BEARING 6004 2RS 20-42-12
4	4397615	SCREW 12x25
5	3000599	PIN M12 L=50
6	4393483	WASHER mm 12 (13,2 x 23.7 x 3)
7	4399943	SCREW 12x35
8	3017334	BUSH 12/18/8,2
9	4399956	SCREW 12x30
10	3006880	SPACER
11	4399865	SELF-LOCKING NUT M12
12	3032834	UPPER HOOK
13	3032835	LOWER HOOK
14	3032877	BEAD BREAK. RUBBER PROT.
15	3010283	HANDLE D.25 M10
16	3019973	HANDLE D.20X120 M10
17	4398284	SCREW 10x30
18	3000114	ARM SPRING
19	7035950	UPPER BEAD BREAKER CARRIAGE
20	4399300	SCREW 6x12
21	7932870	BEAD BREAKER CARR. HOUSING
22	4399946	SCREW 8x16
23	3006880	SPACER
24	2031529	ROLLER HOLDER
25	3006879	SPACER
26	4398657	NUT M12
27	4393807	SCREW STEI 12x25 P.P.
28	4399305	SCREW 8x12
29	4399829	WASHER 8 (8,4x16x1,5)
30	2031530	SHORT SLIDE HOLDER
32	4399967	NUT M10
34	4398848	WASHER 6 (6,6x18x1,5)
35	4293385	COMPRESSION SPRING 14,7X43 F.2
36	4397137	SEEGER RING D.14
37	7034672	SUPPORT BAND STOP
38	3033450	STOP PIN

Ref.	Code	Description
40	4395015	SCREW TBEI M8x16 10.9 UBK
41	4399974	STEEL SHIM 20,5x28x0,5
42	4398214	SCREW 8x16
43	4399976	NUT M8
44	7034688	ADDITIONAL SHOVEL ARM
45	4399981	WASHER 12 (13x24x2,5)
46	4198954	QUICK UNION 6512 1/8" -8 S.R.
47	3000599	PIN M12 L=50
48	3019969	BUSH 12/18/10,5
49	4399865	SELF-LOCKING NUT M12
50	2032885	UPPE CYLINDER UNIT

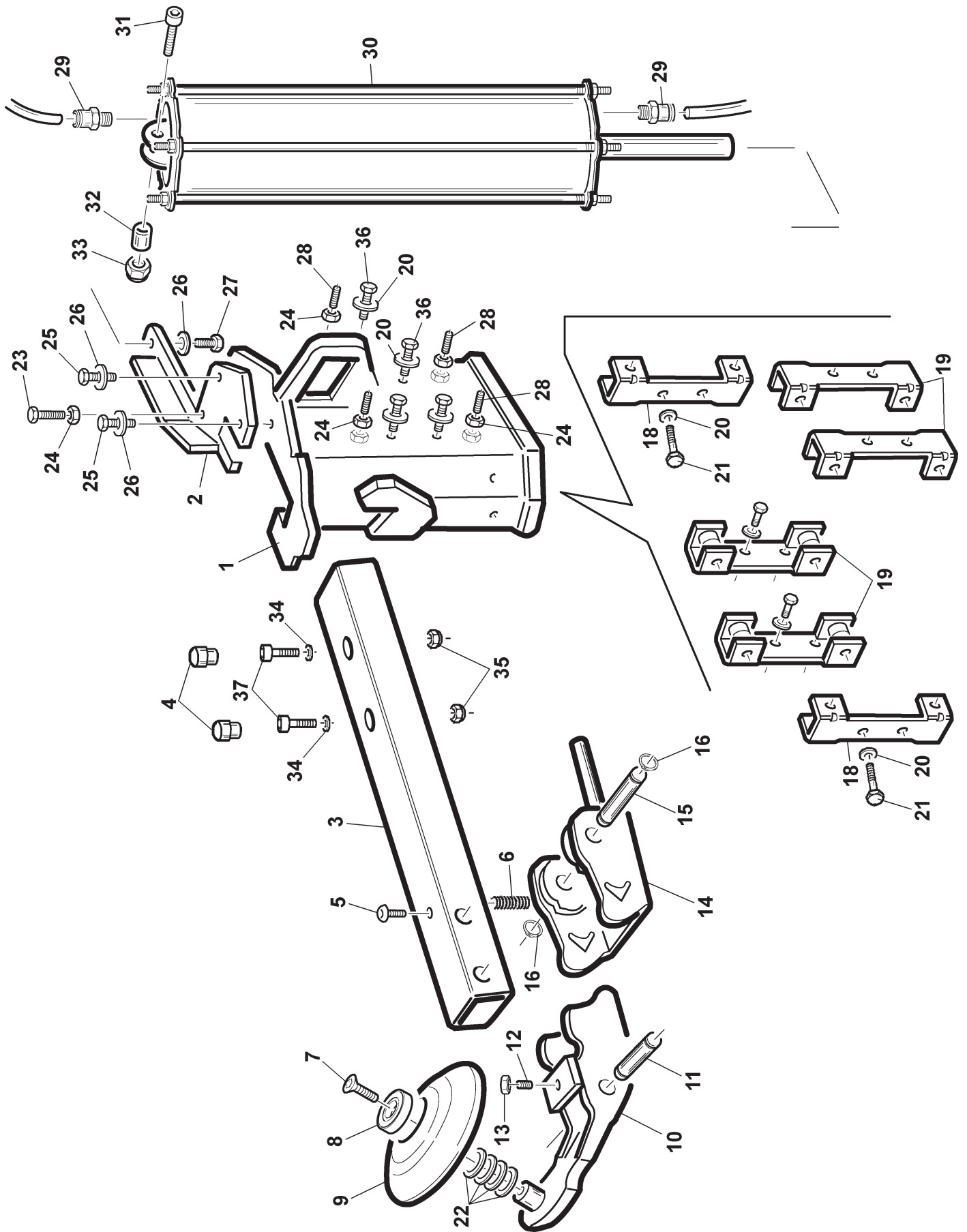

Ref.	Code	Description
1	7032840	BEAD BREAKER CARRIAGE - LOWER -
2	7032848	BEAD BREAK.CARR.FASTENING PLATE
3	7034669	ANCILL.SHOVEL LOWER ARM PIPE
4	3024032	ARM CAP
5	4395015	SCREW TBEI M8x16 10.9 UBK
6	4293385	COMPRESSION SPRING 14,7X43 F.2
7	4397615	SCREW TSPEI M12X25 10.9 ZNT
8	4294264	BALL BEARING 6004 2RS 20-42-12
9	3018464	DISC "S" D.150
10	7034671	ANCILLARY SHOVEL DISK SUPP. PLATE
11	3033450	STOP PIN
12	4398214	SCREW 8x16 5923
13	4399976	NUT M8
14	7034672	SUPPORTING BRACKET STOP
15	3033451	SUPPORT PIN
16	4398686	SEEGER RING D.16
18	2031529	ROLLER HOLDER
19	2031530	SHORT SLIDE HOLDER
20	4399829	WASHER 8 (8,4x16x1,5)
21	4399305	SCREW 8x12
22	4399947	WASHER 8 (9x32x4)
23	4396609	SCREW TE 12x70 8.8 PF
24	4398657	NUT M12
25	4398582	SCREW 12x25
26	4399981	WASHER 12 (13x24x2,5)
27	4397504	SCREW 12x30
28	4393807	SCREW STEI 12x25 P.P. 5923
29	4198954	QUICK UNION 6512 1/8" -8 S.R.
30	2032888	LOWER CYLINDER UNIT
31	3000599	PIN M12 L=50
32	3019969	BUSH 12/18/10,5
33	4399865	SELF-LOCKING NUT M12
34	3002205	WASHER D.10,5x21x2
35	4399971	ELF-LOCKING NUT M10
36	4399946	SCREW 8x16
37	4399956	SCREW 10x25

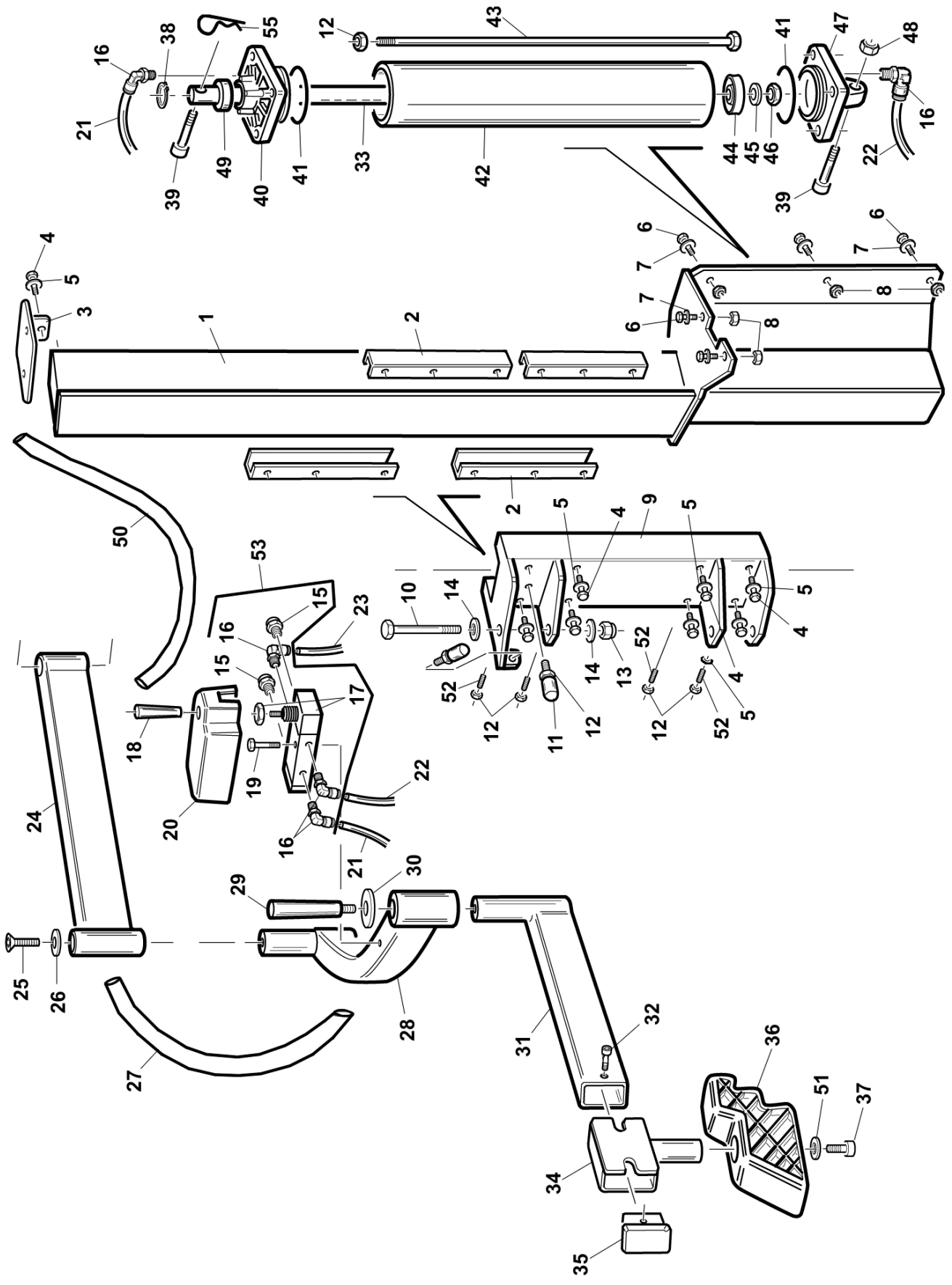

Ref.	Code	Description
1	7019567	PRESS ARM TOWER
2	3019591	ALU SLIDE
3	3019580	SUPPORT
4	4399305	SCREW 8x12
5	4399829	WASHER 8 (8,4x16x1.5)
6	4399228	CREW 10x25
7	4399378	WASHER D.10 (10,5x21x2)
8	4399969	NUT M10
9	7019574	CARRIAGE
10	4396312	SCREW 16x110
11	4294029	BUMPER 24/28 M8
12	4399976	NUT M8
13	4399963	SELF-LOCKING NUT M16
14	4399828	WASHER 16 (17x30x3)
15	4199610	SILENCER 1/8"
16	4198618	UNION 1/8"
17	4198285	5-WAY VALVE
18	3010284	KNOB D.14X45 M5
19	4399897	SCREW 4x25
20	3011135	ARM FRAME
21	3019770	HOSE 6X4 WHITE L=2200
22	3019771	HOSE 6X4 LIGHT BLUE L=2700
23	3014460	HOSE 6x4 L=3000
24	7019443	ARM 1
25	4399120	SCREW 10x20
26	3009088	WASHER D.18,8x45x4
27	3019986	PVC SHEATH L=370
28	7019445	ARM 2
29	2012683	HANDLE+SCREW
30	3002311	WASHER D.10,5x45x4
31	2108983	ARM
32	4399300	SCREW 6x12
33	3012715	CYLINDER ROD L=493
34	2115062	ARM SLIDING BLOCK

Ref.	Code	Description
35	3013112	ARM END PART
36	3008404	BEAD-PRESSING TOOL
37	4399298	SCREW 8x16
38	3199599	SEEGER RING D.30
39	3031764	ADAPTOR PIN
40	3015024	FLANGE
41	4298822	O-RING D.68,26x3,53
42	3008858	CYLINDER LINER L=402
43	3008860	BOLT M8x1,25x431
44	4198856	PISTON D.75
45	4398753	WASHER D.12,5x30x3
46	4398657	NUT M12
47	3015023	FLANGE
48	4399865	SELF-LOCKING NUT M12
49	3199601	SCRAPER
50	3019987	PVC SHEATH L=1000
51	4399863	WASHER 8 (9x24x2)
52	4398214	SCREW 8x16
53	2019757	VALVE UNIT
55	4393641	SPLIT PIN "R" 2X50

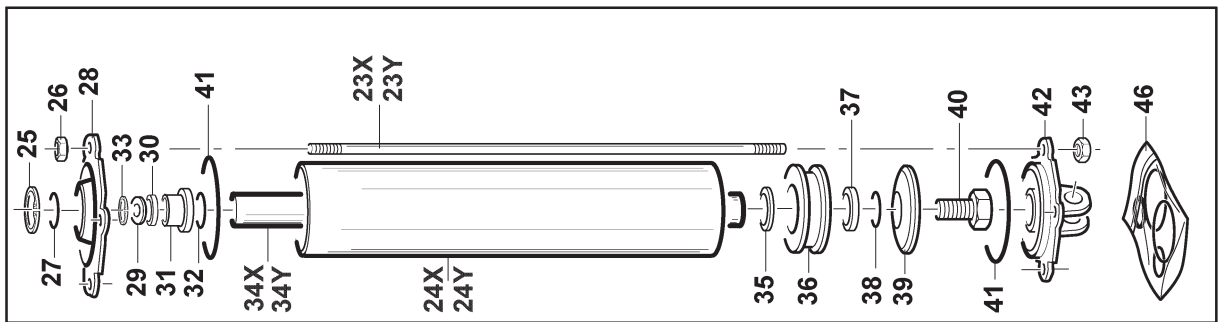
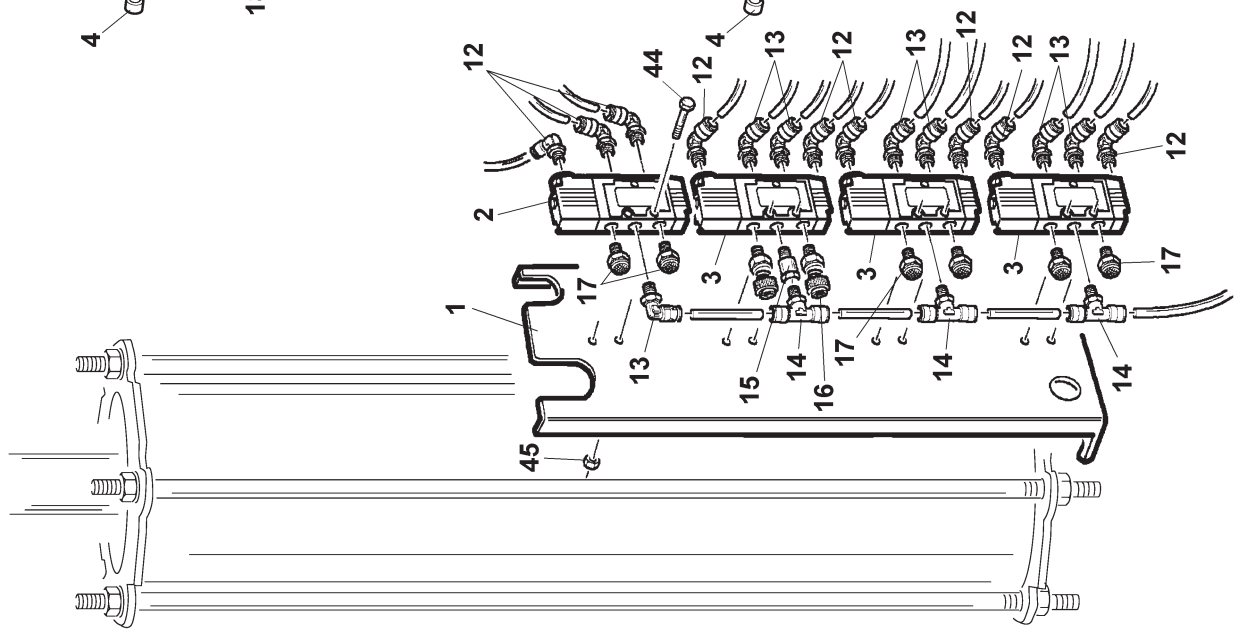
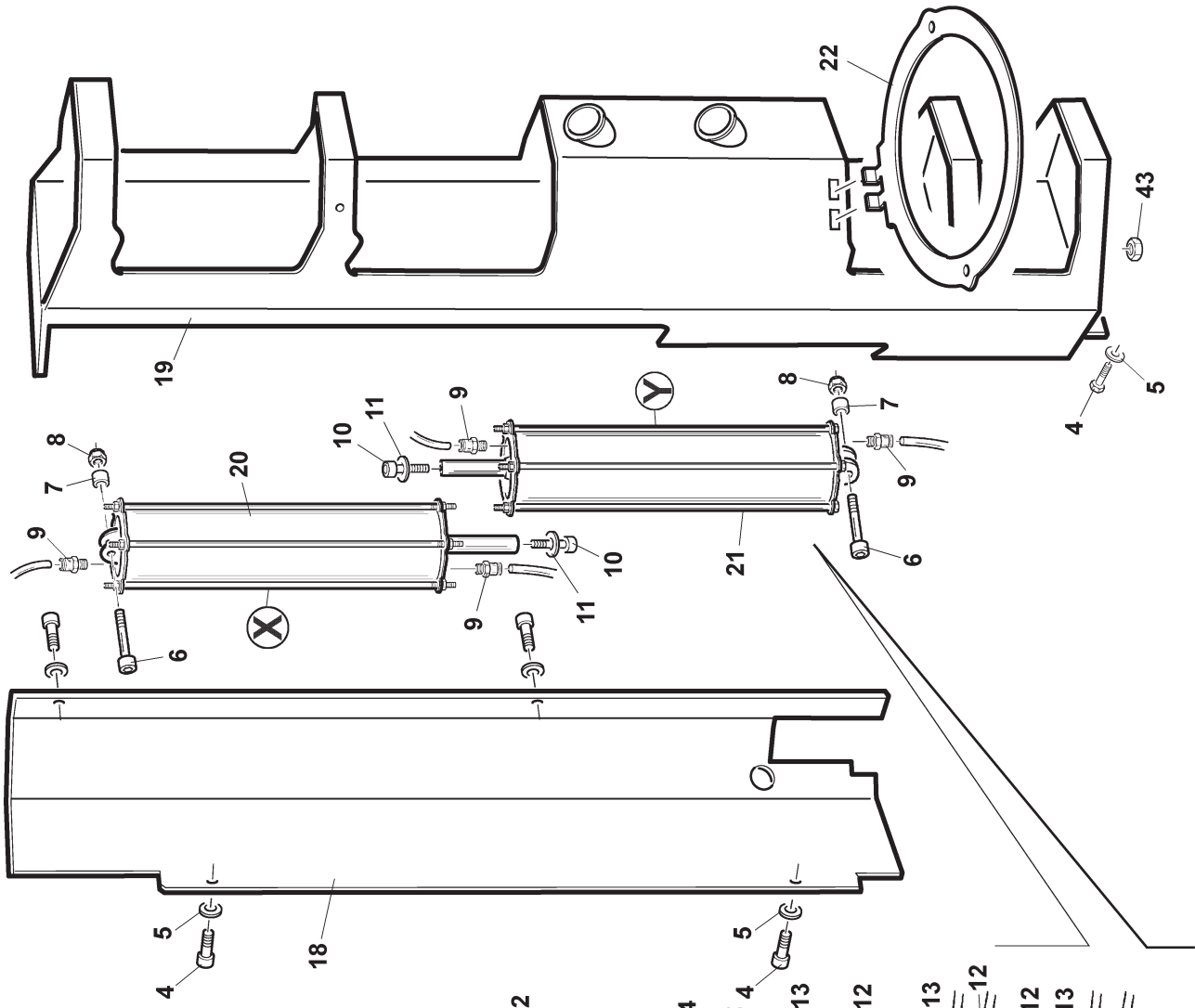

Ref.	Code	Description
1	3032855	TUBE HOLDER PLATE
2	4193997	VALVE VP 1/8" 22 5 PN PM OO P
3	4193998	VALVE VP 1/8" 22 6 PN RC CC P
4	4399300	SCREW 6x12
5	4399998	WASHER 6 (6,4x12x1,6)
6	3000599	PIN M12 L=50
7	3019969	BUSH 12/18/10,5
8	4399865	SELF-LOCKING NUT M12
9	4198954	QUICK UNION 6512 1/8" -8 S.R.
10	4397504	SCREW 12x30
11	4399981	WASHER 12 (13x24x2,5)
12	4197210	UNION 1/8"
13	4196214	UNION 6520 1/8"
14	4196909	6430 QUICK UNION 1/8" -8
15	4198921	STUD BOLT 1/8" H=16
16	4199843	SILENCER OUTLET REG. 1/8"
17	4199610	SILENCER 1/8"
18	7032859	COMPL. BACK CASING
19	7032862	FRONT CASING
20	2032885	UPPE CYLINDER UNIT
21	2032888	LOWER CYLINDER UNIT
22	3035873	GREASE HOLDING RING
23X	3032964	CYLINDER TIE ROD
23Y	3032965	LOWER CYLINDER TIE ROD
24X	3032886	UPPER CYLINDER LINER D.125
24Y	3032889	LOWER CYLINDER LINER D.125
25	4394721	SEGER RING D.36 7435
26	4398805	NUT M12
27	4294713	ORING 3150 37,77x2.62
28	3017341	CYLINDER FLANGE D.125
29	4398146	STEEL SHIM 24x30x1
30	3199601	SCRAPER RING
31	3017346	SEALS BUSH
32	4299168	O-RING 20,29x2.62

Ref.	Code	Description
34X	3032887C	UPPER BEAD BREAK CYL. SHAFT
34Y	3032890C	LOWER BEAD BREAK CYL. SHAFT
35	3017364	WASHER 12,3X40X5
36	4294724	PISTON TDUOP D.125
37	3017365	BUSH 12/18/7,5
38	4297691	O-RING D.12,29x3,53
39	3017344	SPACER FOR PISTON
40	4399431	SCREW 12x45
41	4294722	O-RING 3475 120,32x2,62
42	2119448	CYLINDER BACK FACE D.125
43	4399865	SELF-LOCKING NUT M12
44	4399898	SCREW 4x30
45	4396106	NUT M4
46	2037953	SEALINGS KIT

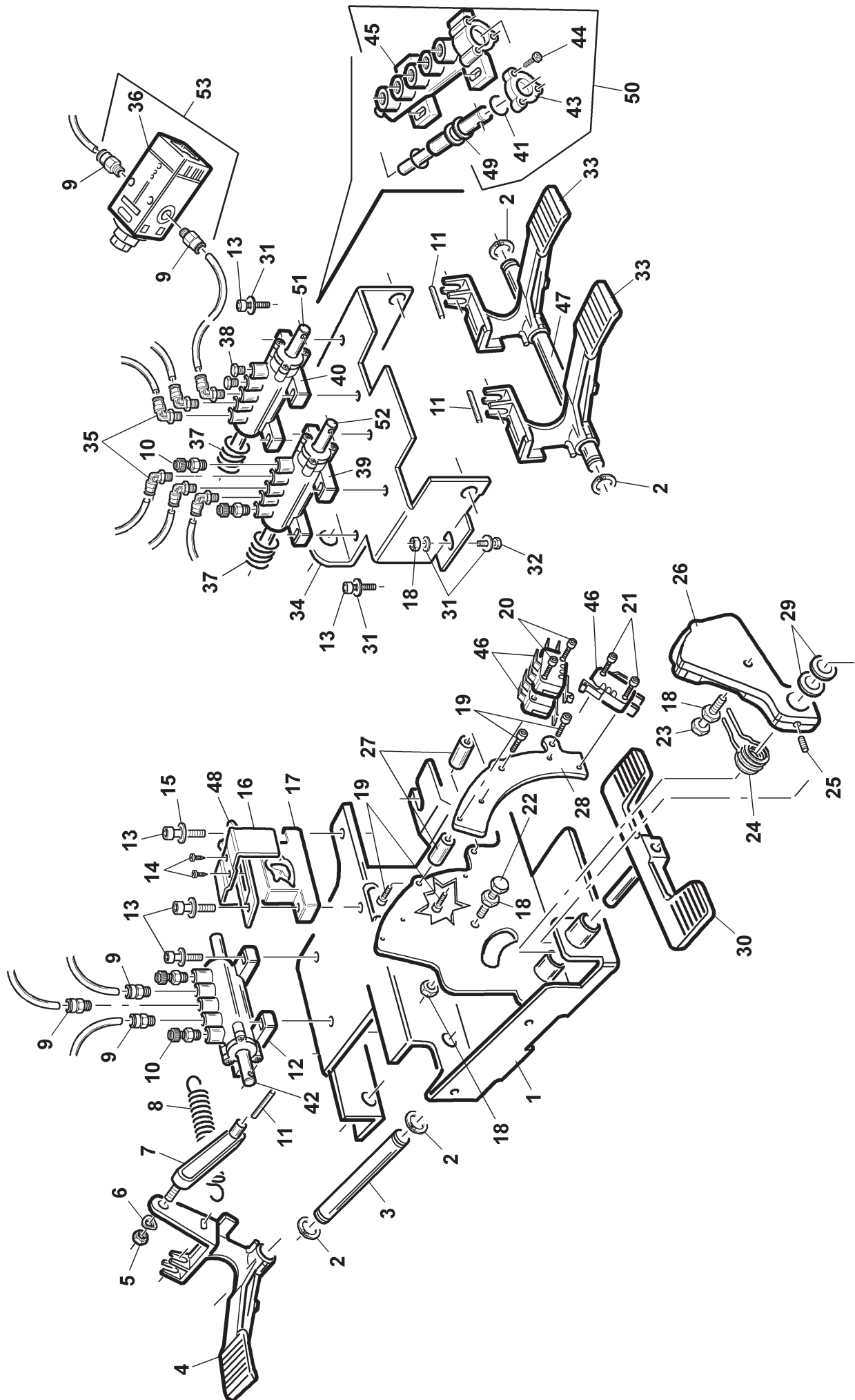

Ref.	Code	Description
1	2119697	PEDAL UNIT
2	4399864	SEEGER RING D.12
3	3019464	PEDAL PIVOT SHAFT
4	3002160	CONTROL PEDAL
5	4399900	SELF-LOCKING NUT M8
6	4399894	BELLEVILLE WASHER 8,2x18x1
7	4299912	CONNECTING ROD
8	3013333	PEDAL RETURN SPRING
9	4198884	QUICK UNION 1/4"
10	4199843	SILENCER OUTLET REG. 1/8"
11	4398783	ELASTIC PIN D.4x24
12	2019557	TOWER LIFT VALVE
13	4398274	SELF-TAPPING SCREW 5,5x26
14	4399891	SELF-TAPPING SCREW 2,9x6,5
15	4399998	WASHER 6 (6,4x12x1,6)
16	4299910	U BOLT
17	4299913	DOUBLE CAM
18	4399976	NUT M8
19	4394022	SCREW M 4x10
20	4396382	SCREW M3X25
21	4395156	SCREW M 3X16
22	4399861	SCREW 8x35
23	4398961	SCREW 8x45
24	3017116	PEDAL CONTROL SPRING
25	4398214	SCREW 8x16
26	2119701	CAM
27	3019699	SPACER
28	3019700	SUPPORT PLATE
29	4398637	WASHER D.12x21x2,5
30	2401100	PEDAL
31	4399829	WASHER 8 (8,4x16x1,5)
32	4399935	VITE TE 8x25 8.8 ZNT
33	3031197	TIRE LIFT OP. PEDAL
34	3019320	PEDAL BOX ASSY

Ref.	Code	Description
35	4196214	UNION 1/8"
36	4197027	PRESSURE REPEATER 1/4"
37	3019989	RETURN SPRING
38	4199161	PLUG 1/8"
39	2019990	TIRE LIFT AIR VALVE
40	2019522	TUBELESS INFLATION VALVE
41	4299000	O-RING 9,8x3,85
42	3002442	VALVE PIN
43	3001585	FLANGE
44	4398999	SELF-TAPPING SCREW 3,5x13
45	3001583	DISTRIBUTION VALVE
46	4593992	MICROSWITCH
47	3019465	PERNO PEDALIERA LATERALE
48	4299911	LEAF SPRING
49	3001584	SPACER
50	2002444	VALVE UNIT WITHOUT PIN
51	3019466	VALVE PIN
52	3031341	VALVE ROD
53	2031214	GR. PRESSURE LIMITER

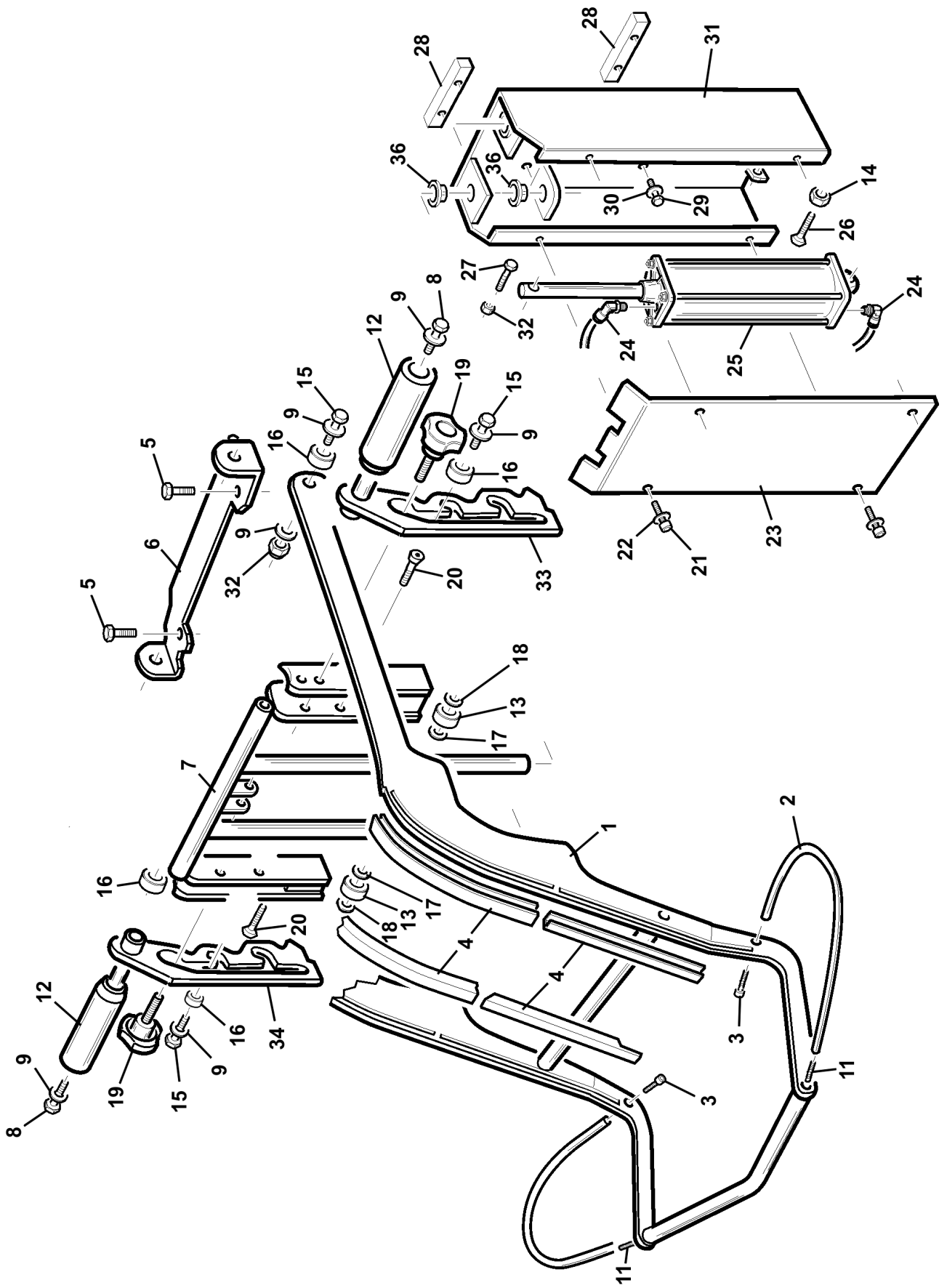

Ref.	Code	Description
1	2119457	LIFT PIVOTING PLATFORM
2	3019636	ELASTOLAN HOSE 6X8 YELLOW
3	4398273	SELF-TAPPING SCREW 5,5x19
4	3019956	LIFT PROTECTIVE BAR L=235
5	4399946	SCREW 8x16
6	3019461	FASTENING PLATE
7	2119452	LIFT STAND
8	4398182	SCREW 12x16
9	3031264	WASHER
12	3019007	ROLLER L=160
13	4296640	BALL BEARING
14	4399865	SELF-LOCKING NUT M12
15	4398582	SCREW 12x25
16	3019969	BUSH 12/18/10,5
17	3017302	FERRULE 12/18/6,5
18	3017334	BUSH 12/18/8,2
19	4297376	HANDWHEEL
20	4396594	SCREW 12x60
21	4399300	SCREW 6x12
22	4399998	WASHER 6 (6,4x12x1,6)
23	7017879	COVER
24	4196214	UNION 1/8"
25	2017884	CYLINDER UNIT
26	3000599	PIN M12 L=50
27	4399089	SCREW 12x40
28	3019895	SHIM
29	4398947	SCREW 8x35
30	4398829	WASHER 8 (8,4x16x1,5)
31	7017860	LIFT FRAME
32	4398657	NUT M12
33	2119939	LEFT OUTER SELECTOR
34	2119938	RIGHT OUTER SELECTOR
36	3014437	BUSH

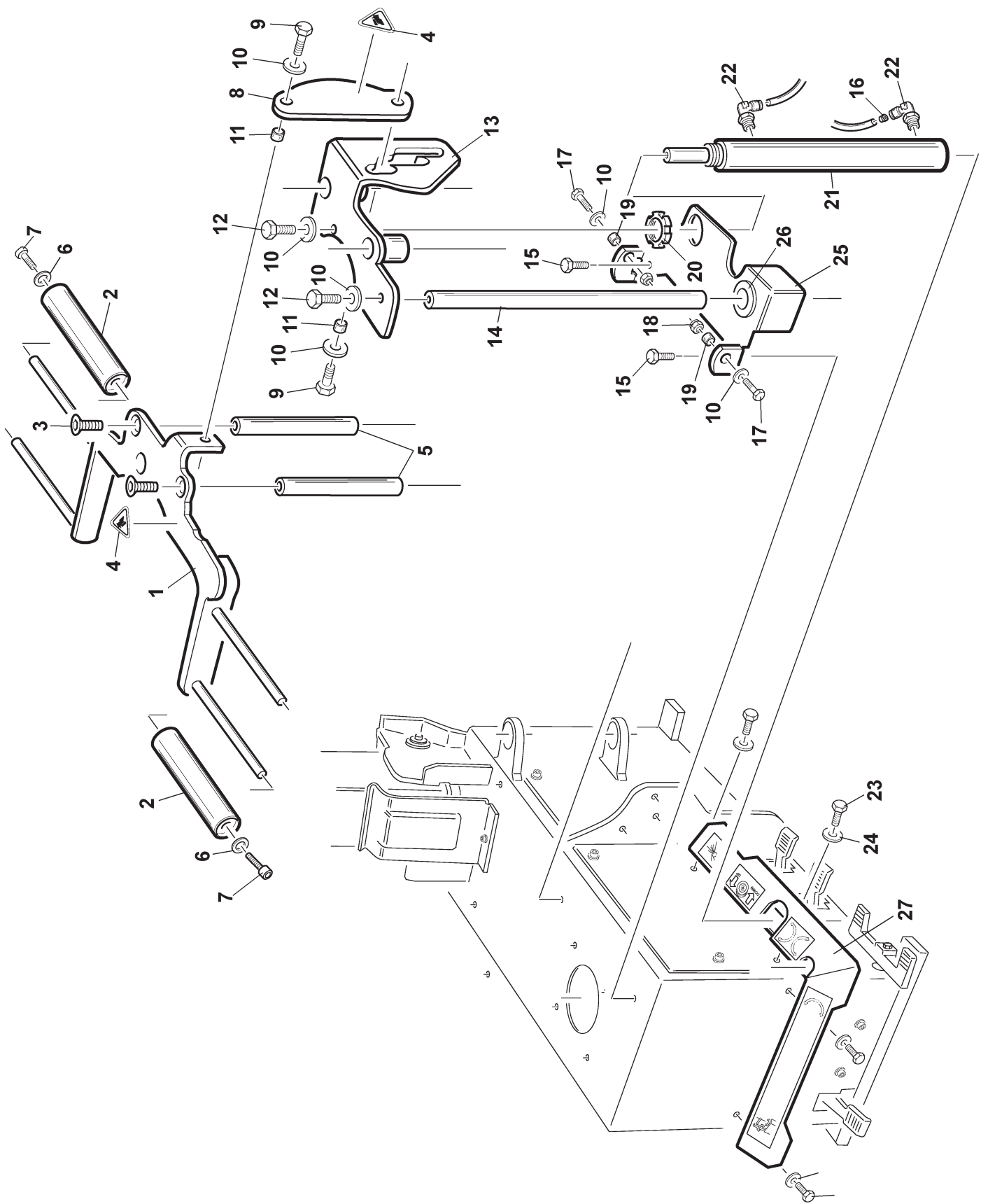

Ref.	Code	Description
1	7036460	ADDITIONAL FORK
2	3019007	LIFT ROLLER
3	4394822	SCREW TSPEI M12x20 10,9 ZNT
4	3033120	DECAL "DANGER OF HAND CRUSH"
5	3036464	FORK GUIDE PIN
6	3031264	ROLLER CONTAINMENT WASHER
7	4394536	SCREW TCEI M12x20 8,8 ZNT
8	3036463	LIFT SELECTOR CONNECTING ROD
9	4399434	SCREW 12x20
10	4399378	WASHER D.10 (10,5x21x2)
11	3017334	BUSH 12/18/8,2
12	4398582	SCREW 12x25
13	7036456	LIFT UPPER SUPPORT
14	3036459	LIFT UPPER SUPPORT GUIDE PIN
15	4399946	SCREW 8x16
16	3036624	RILSAN PIPE HEAD - Ø 8 D.1,4
17	4399982	SCREW 12x30
18	4399865	SELF-LOCKING NUT M12
19	3019969	BUSH 12/18/10,5
20	4395777	SELF-LOCKING RING NUT M35x1,5
21	2036448	LIFT ANCILLARY CYLINDER
22	4196214	UNION 6520 1/8"
23	4399300	SCREW 6x12
24	4399998	WASHER 6 (6,4x12x1,6)
25	7036453	ANCILLARY CYLINDER SUPPORT
26	3014437	BUSH
27	6119415	PEDAL COVER

A

Fino a: 31/12/2010
 Before: 31/12/2010
 Avant: 31/12/2010
 Vor: 31/12/2010

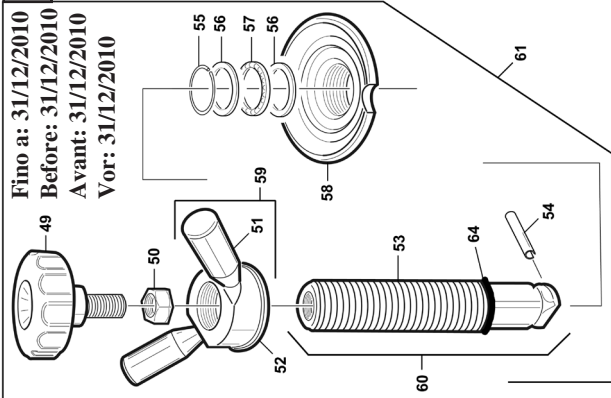
**B**

Da: 01/01/2011
 From: 01/01/2011
 Depuis: 01/01/2011
 Ab: 01/01/2011

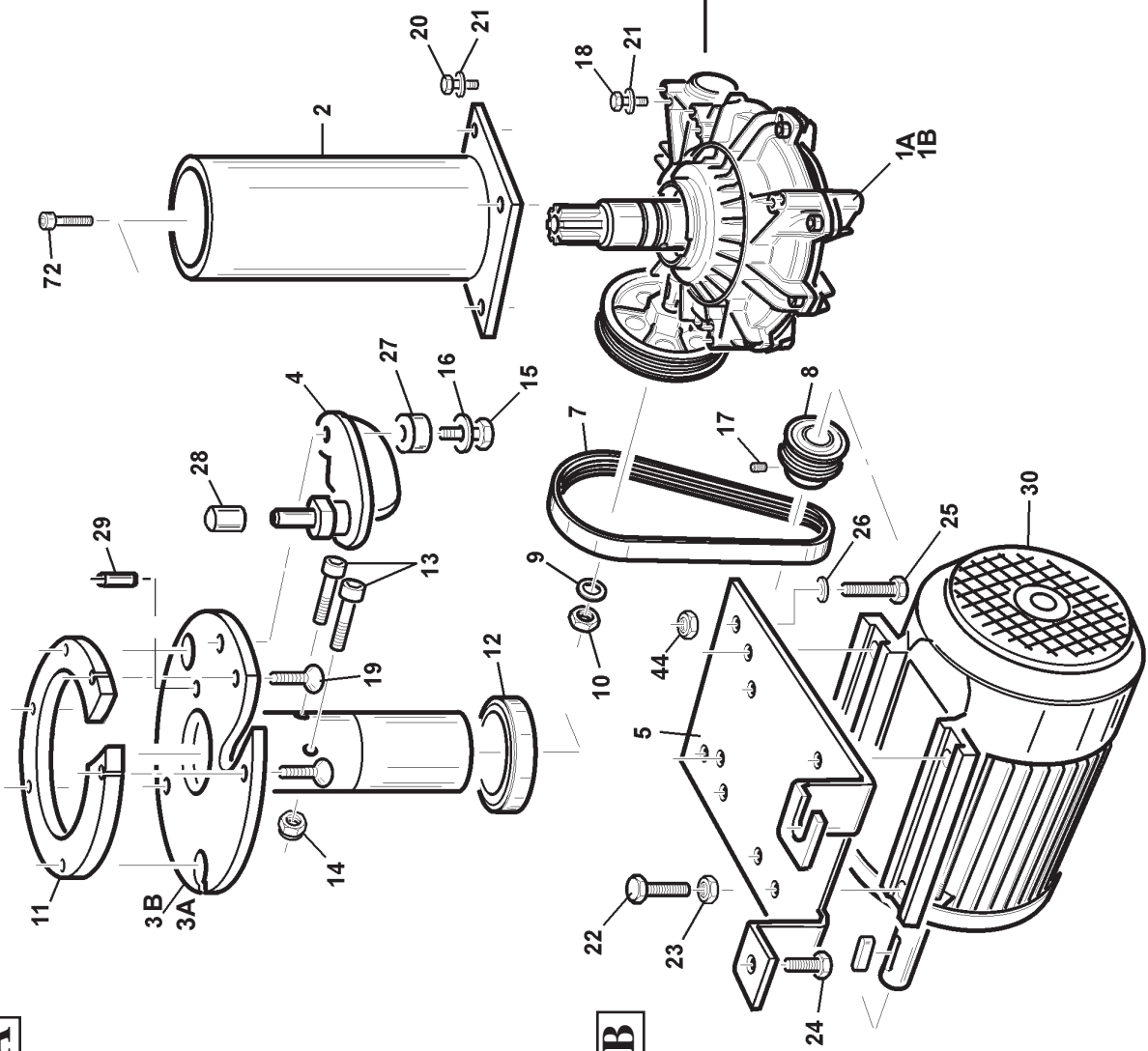
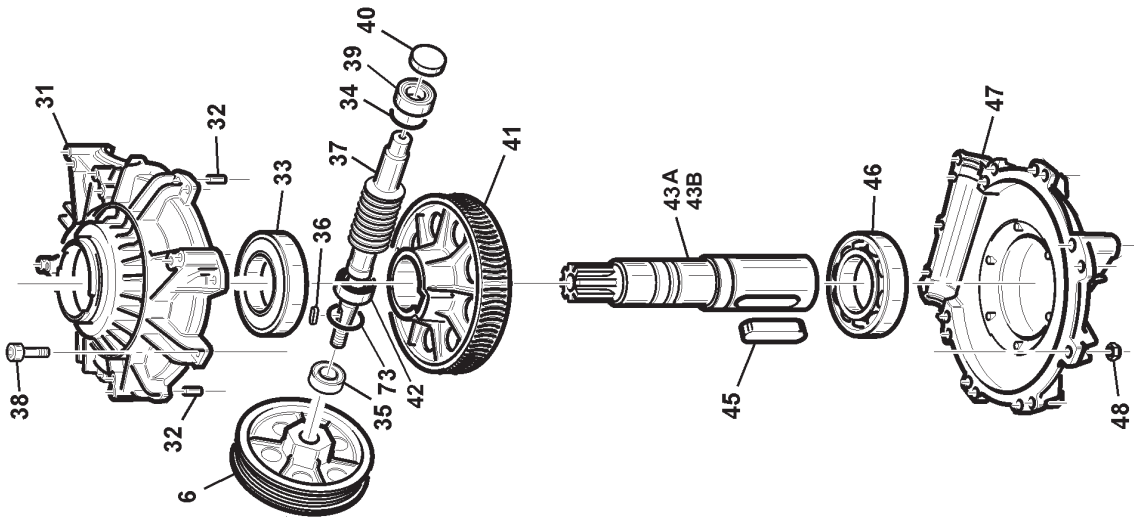
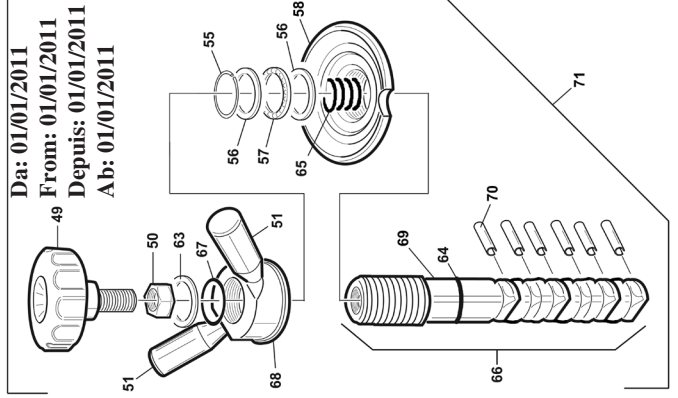

Ref.	Code	Description
1A	2010900	REDUCTION GEAR
1B	2033133	CHUCK REDUCTION GEAR
2	7018063	BEARING SUPPORT
3A	2118666	CHUCK
3B	2133266	QUICK HAND CHUCK
4	2118670	ANTIROTATION DEVICE
5	3000149	MOTOR SUPPORT
6	3010863	GEARBOX PULLEY
7	4293891	BELT PV 584 J6
8	3010864	MOTOR PULLEY
9	4398807	WASHER 14 (15x28x2,5)
10	4396941	NUT M14
11	3018727	ADAPTOR FLANGE
12	4296945	BEARING 60X110X22
13	3019662	SCREW 10X70 CUT
14	4399971	SELF-LOCKING NUT M10
15	4399434	SCREW 12x20
16	4398637	WASHER D.12x21x2,5
17	4399922	SCREW 8x14
18	4399933	SCREW 10x50
19	4399120	SCREW 10x20
20	4399877	SCREW 10x60
21	4399378	WASHER D.10 (10,5x21x2)
22	4399786	SCREW 10x30
23	4399967	NUT M10
24	4399966	SCREW 10x20
25	4399951	SCREW 10x35
26	4399829	WASHER 8 (8,4x16x1,5)
27	3019969	BUSH 12/18/10,5
28	3019971	PIN PROTECTION

Ref.	Code	Description
29	3199580	ELASTIC PIN D.8x20
30X	4598919	2v. MOT. 3PH 400V 50HZ
30Y	4594034	MOTOR 3PH 200/230V 50/60HZ
31	3010872	REDUCTION GEAR BOX
32	4396940	PARALLEL PIN 8x20
33	4296945	BEARING 60X110X22
34	4294205	SEAL D.40X35X4 NBR 75
35	4296944	BEARING
36	4396947	TAB 6X6X18
37	3010883	WORM
38	4399134	SCREW 8x30
39	4296944	BEARING
40	3010886	SEALING CAP
41	3010884	HELICAL GEAR
42	4396700	SEEGER RING D.50
43A	3010885	PIN
43B	3010916	PIN
44	4399964	SCREW 6x10
45	4396948	TAB 16X10X70
46	4296910	BEARING 60X110X22
47	3010873	BOX
48	4399900	SELF-LOCKING NUT M8
49	4294010	HANDWHEEL 16x35
50	4398498	NUT M16
51	3018676	RING NUT HANDLE
52	3018675	RING NUT
53	3018673	CHUCK SCREW
54	4398783	ELASTIC PIN D.4x24
55	4294007	STOP RING
56	4294008	WASHER

Ref.	Code	Description
57	4294009	FIFTH WHEEL
58	3018680	CONE
59	2018674	RING NUT
60	2031195	SHAFT UNIT + ELASTIC PIN
61	2031196	CHUCK CLAMP UNIT
62	3018677	SPRING
63	4398751	WASHER 14 (16x42x3)
64	4393982	O-RING
65	3033023	SPRING
66	2033341	MILLED SCREW + PLUGS
67	4296882	O-RING 31,42x2,62
68	3033280	QUICK LOCKING RING NUT BODY
69	3033262	QUICK CHUCK SCREW
70	4393254	ELASTIC PIN D.4X10
71	2033343	QUICK CHUCK LOCKING UNIT
72	4393981	SCREW TCEI M 16x1,5x50 - ZNT

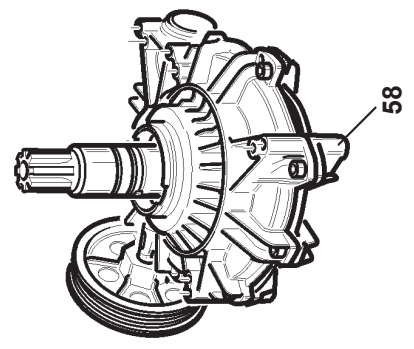
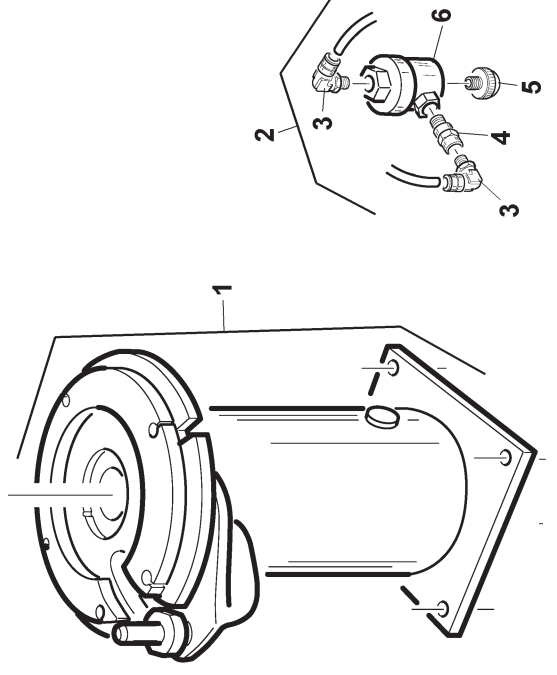
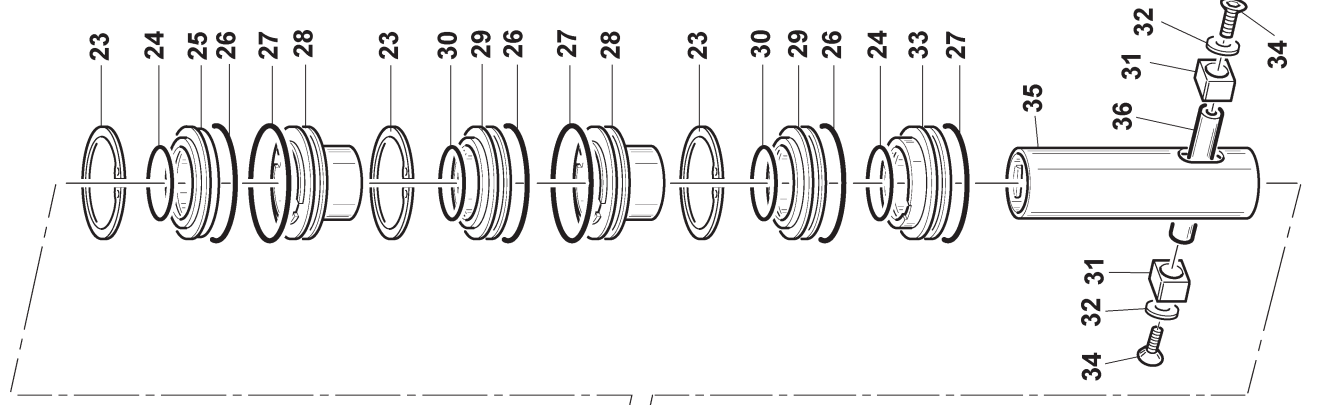
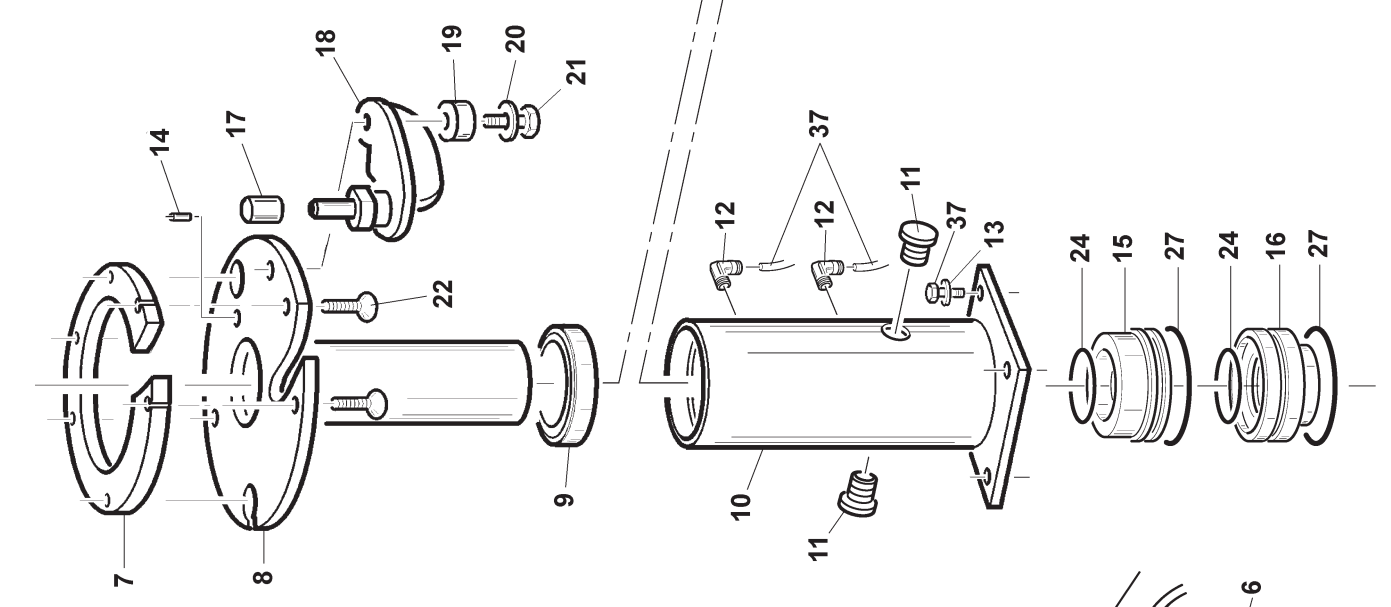
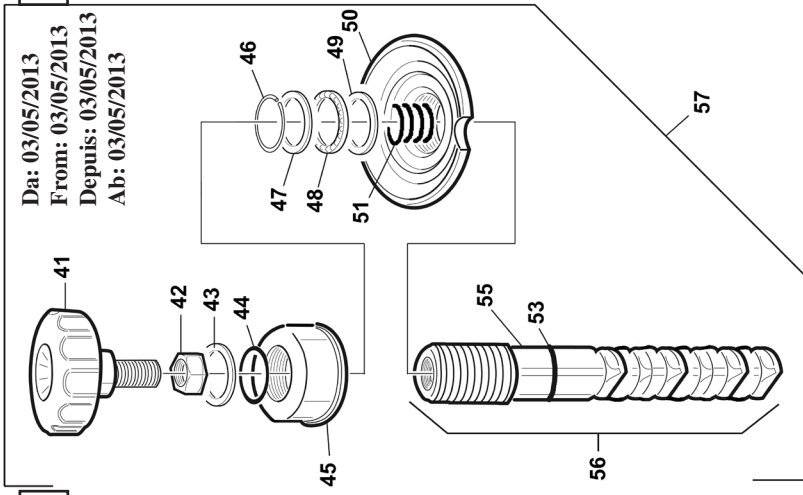
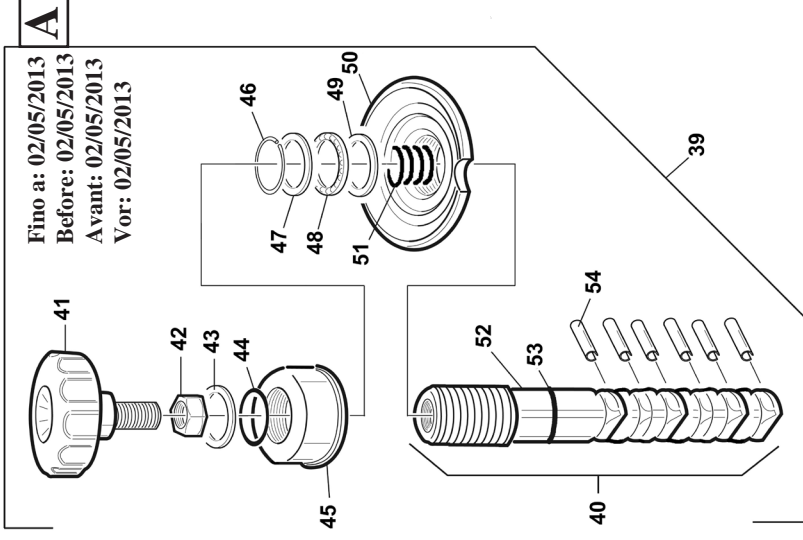

Ref.	Code	Description	Ref.	Code	Description
1	2033055	PNEUMATIC CHUCK UNIT	31	3033014	CHUCK SLIDE
2	2033135	QUICK RELIEF VALVE UNIT	32	4399981	WASHER 12 (13x24x2,5)
3	4197210	UNION 1/8"	33	3033008	UPPER ROLLER PISTON
4	4198803	REDUCTION PIECE 1/4"-1/8"	34	4398746	SCREW TSPEI M 8x14 10.9 ZNT
5	4198808	SILENCER 1/4"	35	2133026	SLIDER
6	4199671	QUICK RELIEF VALVE 1/4"	36	3033015	CHUCK PIN
7	3018727	ADAPTOR FLANGE	37	4399877	SCREW 10x60
8	2133021	CHUCK UNIT	38	3033121	HOSE D.4X2,7 BLACK L=4500
9	4296945	BEARING 60X110X22	39	2033343	QUICK CHUCK LOCKING UNIT
10	7033020	BEARING ANCILLARY SUPPORT	40	2033341	MILLED SCREW + PLUGS
11	4293336	PLUG ILTB 30X0,8-2,5	41	3013281	HANDWHEEL M16 V1/70/V-M16X43
12	4197741	UNION 1/8"	42	4398498	NUT M16
13	4399378	WASHER D.10 (10,5x21x2)	43	4398751	WASHER 14 (16x42x3)
14	3199580	ELASTIC PIN D.8x20	44	4296882	O-RING 31,42x2,62
15	3033013	LOWER ROLLER PISTON	45	3033016	SPRING CAP
16	3033012	REDUCTION GEAR FLANGE	46	4294007	STOP RING
17	3019971	PIN PROTECTION	47	4294008	WASHER
18	2118670	ANTIROTATION DEVICE	48	4294009	FIFTH WHEEL
19	3019969	BUSH 12/18/10,5	49	4294008	WASHER
20	4398637	WASHER D.12x21x2,5	50	3018680	CONE
21	4399434	SCREW 12x20	51	3033023	SPRING
22	4399120	SCREW 10x20	52	3033262	QUICK CHUCK SCREW
23	4393562	SEEGER RING I D.105 7437	53	4393982	O-RING
24	4293560	O-RING 4237 D.59,92X3,53	54	4393254	ELASTIC PIN D.4X10
25	3033010	UPPER FLANGE	55	3033022	MILLED CHUCK SCREW
26	4293561	O-RING 4400 D.101,19X3,53	56	2037540	MILLED SCREW
27	4299325	O-RING D.98,02x3,53	57	2033054	SCREW+CHUCK CONE UNIT
28	3033009	PISTON	58	2033133	CHUCK REDUCTION GEAR
29	3033011	INTERMEDIATE FLANGE			
30	4293559	O-RING 4275 D.69,44X3,53			

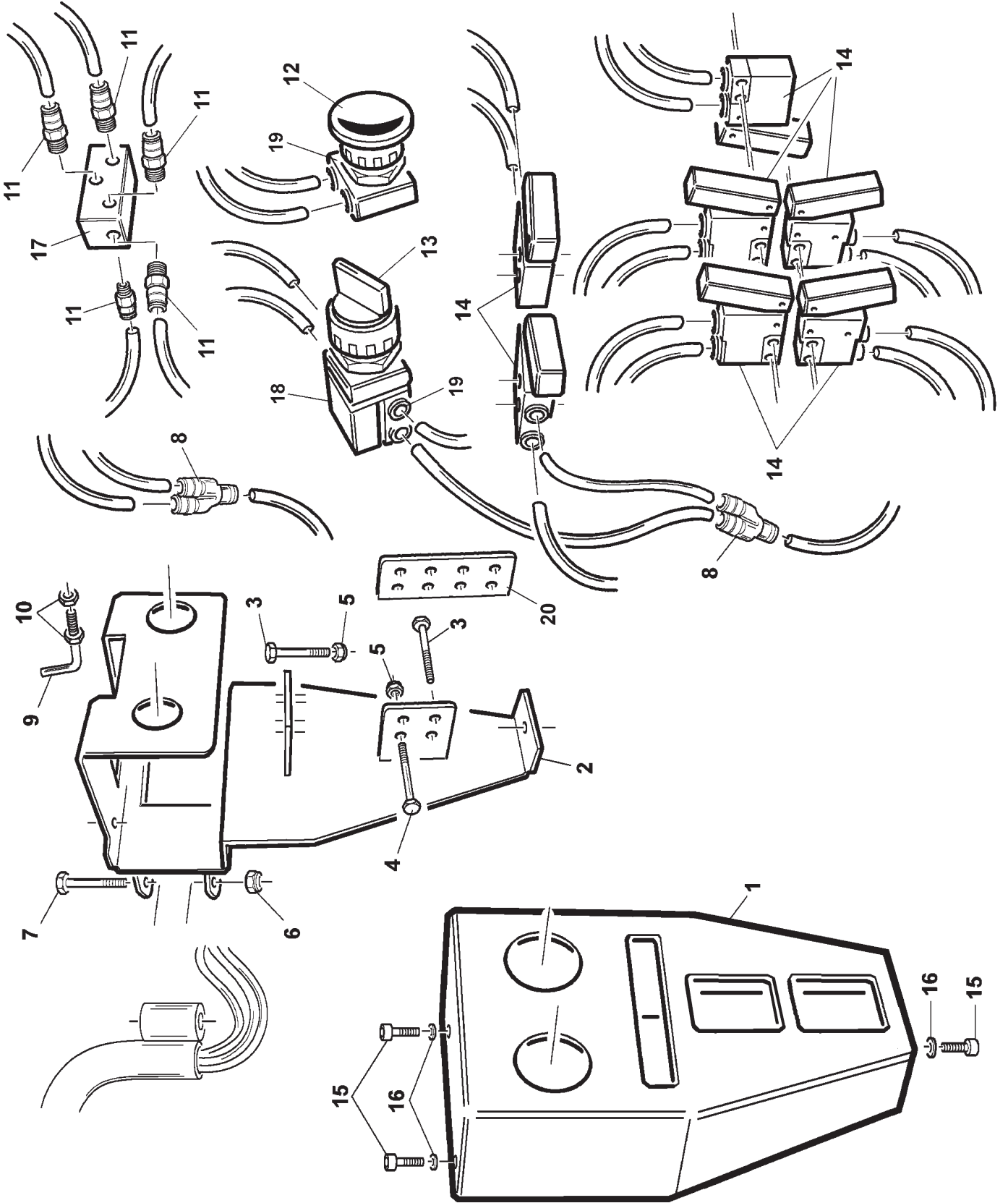

Ref.	Code	Description
1	7032876	COVER
2	7032872	MAIN FRAME
3	4399897	SCREW 4x25
4	4397513	SCREW 4x45
5	4396106	NUT M4
6	4399976	NUT M8
7	4398961	SCREW 8x45
8	4197293	Y-UNION D.4
9	3012978	HOOK
10	4399889	NUT M6
11	4197742	QUICK UNION 1/8"
12	4193995	PUSH BUTTON RT050N
13	4193996	SELECTOR RT300N
14	4194001	VALVE MV AL4 15 3 LT ML NC P
15	4399300	SCREW 6x12
16	4399998	WASHER 6 (6,4x12x1,6)
17	3019473	AIR VALVE
18	4193999	VALVE MV AL4 15 3 PB ML NO P
19	4194000	VALVE MV AL4 15 3 PB ML NC P
20	3032875	PLATE

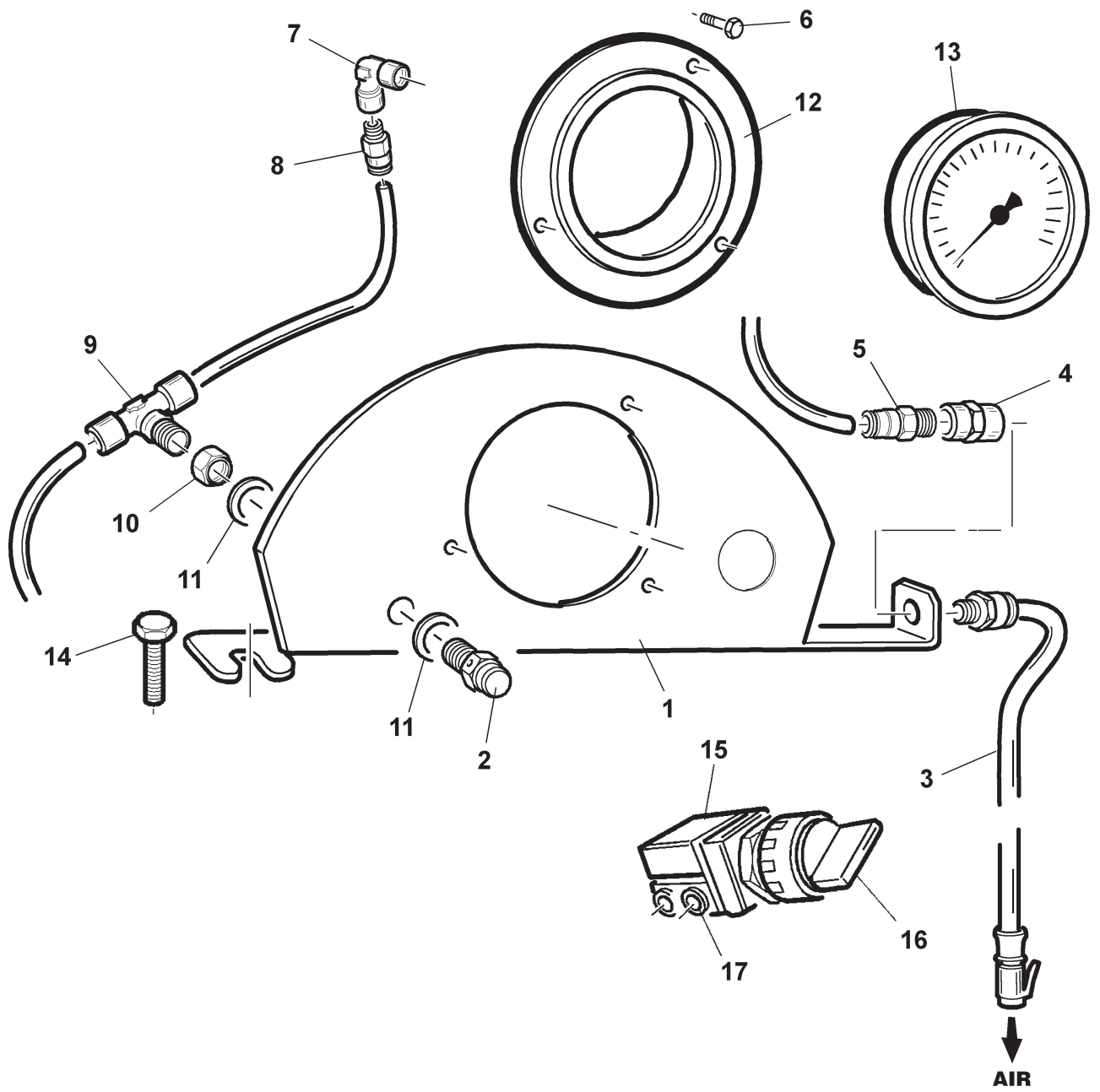

<i>Ref.</i>	<i>Code</i>	<i>Description</i>
1	6119413	AIR GAUGE SUPPORT PLATE
2	4299354	RELIEF PUSHBUTTON
3	2017392	INFLATING PIPE L=2000
4	4198894	COUPLING 2543 1/4" F
5	4198884	QUICK UNION 1/4"
6	4399038	SCREW 4x8
7	4199109	UNION 1/4"
8	4198884	QUICK UNION 1/4"
9	4198885	QUICK UNION 1/4"
10	4198894	COUPLING 2543 1/4" F
11	4196920	NYLON WASHER 1/4"
12	3002351	FLANGE
13	4299069	PRESSURE GAUGE D.80
14	4399305	SCREW 8x12
15	4193999	VALVE MV AL4 15 3 PB ML NO P
16	4193996	SELECTOR RT300N
17	4194000	VALVE MV AL4 15 3 PB ML NC P

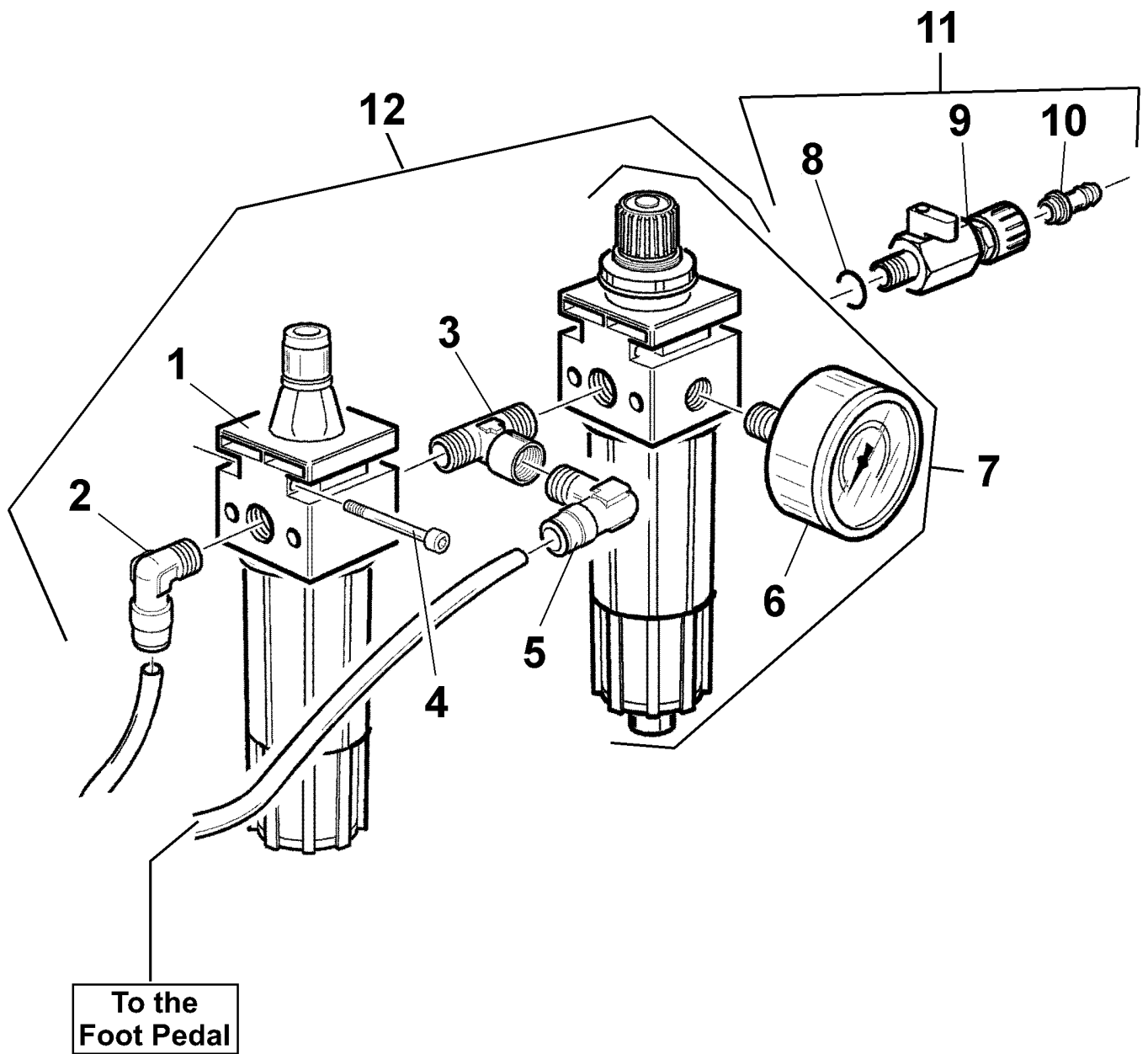

<i>Ref.</i>	<i>Code</i>	<i>Description</i>
1	4196481	LUBRICATOR
2	4198883	QUICK UNION 1/4"
3	4198973	UNION 1/4"
4	4396593	SCREW 4 X 40
5	4198883	QUICK UNION 1/4"
6	4198071	PRESSURE GAUGE D.40
7	4196480	FILTER
8	4295590	O RING D.12, 42 X 1,78
9	4196354	VALVE 400 1/4" F-F
10	4199987	CONNECTION
11	2012960	INTAKE UNIT
12	2012307	LUBRICATOR + FILTER REGULATOR

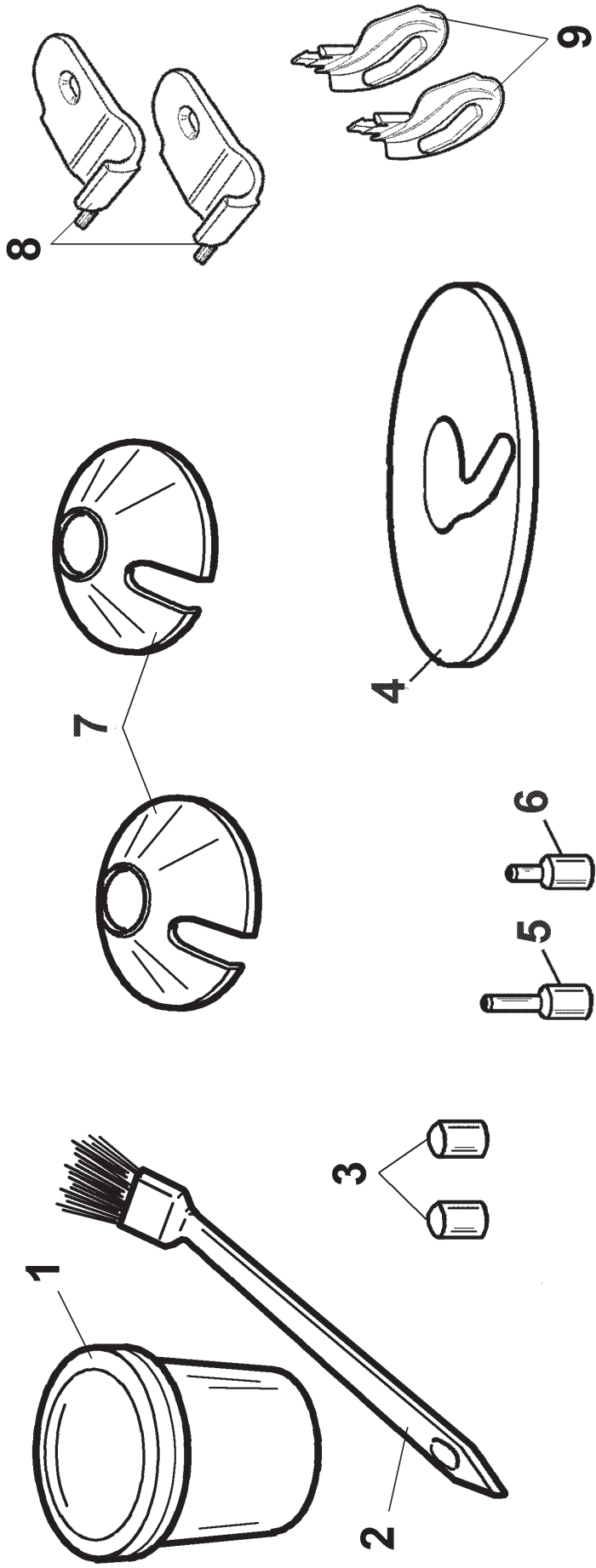

Ref.	Code	Description
1	3008610	GREASE CUP
2	4296517	BRUSH
3	43019971	PIN PROTECTION
4	3031347	CHUCK PROTECTIVE CAP
5	3031335	EXTENSION PIN L=72
6	3032133	EXTENSION PIN L=33
7	3019057	CONE PROTECTION
8	3032278NE	C FRONT PROTECTION - NEUTRAL
9	3019305NE	TOOL BACK SLIDE - NEUTRAL COLOUR

