

# COATS®

## H.I.T. 9000

# TRUCK TIRE CHANGER



## Installation Instructions Operating Instructions Safety Instructions Maintenance Instructions

READ these instructions before placing unit in service KEEP these and other materials delivered with the unit in a binder near the machine for ease of reference by supervisors and operators.

**HENNESSY INDUSTRIES, INC.**

1601 J. P. Hennessy Drive, LaVergne, TN USA 37086-3565 615/641-7533 800/688-6359

HENNESSY INDUSTRIES INC. Manufacturer of AMMCO®, COATS® and BADA® Automotive Service Equipment and Tools.

Manual Part No.: 9110847 01

Revision: 01/02

# Safety

# Contents

## Table of Contents

<b>Operator Protective Equipment</b> .....	<b>.iv</b>
<b>Definitions of Hazard Levels</b> .....	<b>.iv</b>
<b>Safety Instructions</b>	
Bead Loosening .....	.v
Demounting & Mounting .....	.v
Inflation .....	.v
<b>Installation</b> .....	<b>.vi</b>
<b>Electrical Installation</b> .....	<b>.vi</b>
<b>Principal Operating Parts</b>	
Specifications .....	.1
<b>Wheel Clamping</b> .....	<b>.2</b>
<b>Tubeless, Duplex, and Supersingle Tires</b>	
Bead Loosening .....	.3
Demounting .....	.3 - 4
Mounting .....	.4
<b>Wheels with Lock Rings</b>	
Bead Loosening and Demounting .....	.5
Mounting .....	.5
<b>Farm Tires</b>	
Bead Loosening .....	.6
Demounting .....	.6 - 7
Mounting .....	.7
<b>Tire Spreading</b>	
Method A: .....	.8
Method B: .....	.8
<b>Maintenance</b> .....	<b>.9</b>
<b>Truck Tire Changer Warranty Policy</b> .....	<b>.Back</b>
<b>Service Policy</b> .....	<b>.Back</b>

# Safety



Failure to follow danger, warning, and caution instructions may lead to serious personal injury or death to operator or bystander or damage to property. Do not operate this machine until you read and understand all the dangers, warnings and cautions in this manual. For additional copies of either, or further information, contact:

**Hennessy Industries, Inc.**

1601 J.P. Hennessy Drive  
LaVergne, TN 37086-3565  
(615) 641-7533 or (800) 688-6359  
www.ammcoats.com

## Operator Protective Equipment

Personal protective equipment helps make tire servicing safer. However, equipment does not take the place of safe operating practices. Always wear durable work clothing during tire service activity. Loose fitting clothing should be avoided. Tight fitting leather gloves are recommended to protect operator's hands when handling worn tires and wheels. Sturdy leather work shoes with steel toes and oil resistant soles should be used by tire service personnel to help prevent injury in typical shop activities. Eye protection is essential during tire service activity. Safety glasses with side shields, goggles, or face shields are acceptable. Back belts provide support during lifting activities and are also helpful in providing operator protection. Consideration should also be given to the use of hearing protection if tire service activity is performed in an enclosed area, or if noise levels are high.

## Definitions of Hazard Levels

Identify the hazard levels used in this manual with the following definitions and signal words:

### DANGER

Watch for this symbol:



It Means: Immediate hazards, which will result in severe personal injury or death.

### WARNING

Watch for this symbol:



It Means: Hazards or unsafe practices, which could result in severe personal injury or death.

### CAUTION

Watch for this symbol:



It Means: Hazards or unsafe practices, which may result in minor personal injury or product or property damage.



Watch for this symbol! It means BE ALERT! Your safety, or the safety of others, is involved!

# Safety

## Safety Instructions



**Only properly trained personnel should service tires on the H.I.T. 9000. Read all safety and operating instructions thoroughly before using the tire changer.**

*ALWAYS* remove all wheel weights and the valve core to deflate the tire before servicing.

*ALWAYS* cover the electric motor and switch box before hosing down the tire changer. Be sure water does not enter the motor or switch box.

*ALWAYS* disconnect the electric power and air supply before attempting any maintenance.

*ALWAYS* keep all working surfaces clean and free of tire lube buildup.

*ALWAYS* be aware of what each person is and will do before attempting any two-person operation.

### Bead Loosening

*NEVER* place anything between the bead loosener disc and the tire/wheel.

*NEVER* place any part of your body between the bead loosener disc and the tire/wheel, severe bodily injury may result.

*NEVER* allow the bead loosener to contact the wheel, wheel damage may occur.

### Demounting & Mounting

*NEVER* stand on the working table while demounting or mounting a tire.

*ALWAYS* keep hands, feet, and other objects away from moving parts while the machine is turned on.

*ALWAYS* place the narrow bead seat to the outside when clamping. Failure to demount the tire from the narrow bead seat side may cause damage to the tire beads.

*ALWAYS* apply an approved rubber lubricant to rim flanges and both tire beads before demounting or mounting and seating the beads. *NEVER* use antifreeze, silicone, or petroleum base lubricants.

*ALWAYS* clean and inspect the wheel.

*NEVER* mount a tire on a damaged or rusty wheel. Wheel damage or rust may cause tire or wheel failure during inflation. Explosion from failure may result in severe injury or death of the operator and bystanders.

*ALWAYS* be sure the bead opposite the tool is in the drop center before rotating the tire when demounting or mounting to avoid damage to the tire beads.

### Inflation

*ALWAYS* follow all applicable Local, State, and Federal Codes, Rules, and Regulations; such as the Federal OSHA Standard Number 1910.177.

*NEVER* seat beads or inflate a tire on the tire changer. The H.I.T. 9000 is not designed as a safety device or stand for bead seating or inflation.

*ALWAYS* use an approved inflation chamber or inflation cage.

The following safety instructions are for one piece wheels only. Refer to the manufacturer's or R.M.A. procedures for multipiece wheels.

*ALWAYS* use an approved inflation chamber or inflation cage equipped with a grip chuck and a remote inflation gauge and valve. **DO NOT OVER INFLATE!** Tire or wheel failure during and after inflation may result in an explosion capable of causing severe injury or death.

*ALWAYS* inflate the tire to manufacturer's recommended cold operating pressure.

*NEVER* reinflate a tire that has been run underinflated or flat without first demounting the tire and checking for wheel and tire damage.

*ALWAYS* inspect the tire interior for loose or broken cords, cuts, penetrating objects, and other damage to the carcass. Discard tires that cannot be properly repaired.

*NEVER* rework, weld, heat or braze wheels.

*NEVER* strike the tire or wheel with a hammer.

*ALWAYS* be sure the tire diameter exactly matches the wheel diameter.



**Tire failure under pressure can be hazardous. Place the wheel inside an approved inflation chamber or cage before inflating. Use an approved remote inflation valve, hose, and gauge. ALWAYS wear safety goggles for eye protection. Do not stand beside the wheel or cage during inflation. Keep hands and other parts of the body out of the cage during inflation. Observe the tire pressure frequently. Do not exceed the manufacturer's recommended maximum inflation pressure. Failure to follow these instructions may cause the tire and rim to separate with tremendous force, resulting in serious personal injury or death.**

# H.I.T. 9000

## Installation

It is not necessary to bolt the H.I.T. 9000 to the floor. However, if desired, use the holes provided in the base of the machine.



**Most electrical codes require machinery that is permanently installed to be wired directly to the power source via conduit.**

Remove the H.I.T. 9000 from the shipping pallet and position on a relatively level and smooth floor, preferably concrete.

**Important:** Read this operators manual thoroughly before attempting to change any tires. Also, actuate the controls several times to become familiar with their function and direction.

## Electrical Installation

The H.I.T. 9000 requires 220 volts, 60 cycle, single phase power, with a 20 amp circuit. An optional model is available for 110 volt, single phase or 220 volt, 3 phase power.

**Important:** Have a licensed electrician connect the H.I.T. 9000 to the power source. The licensed electrician must sign the warranty registration card to validate the warranty.

# H.I.T. 9000

## Principal Operating Parts

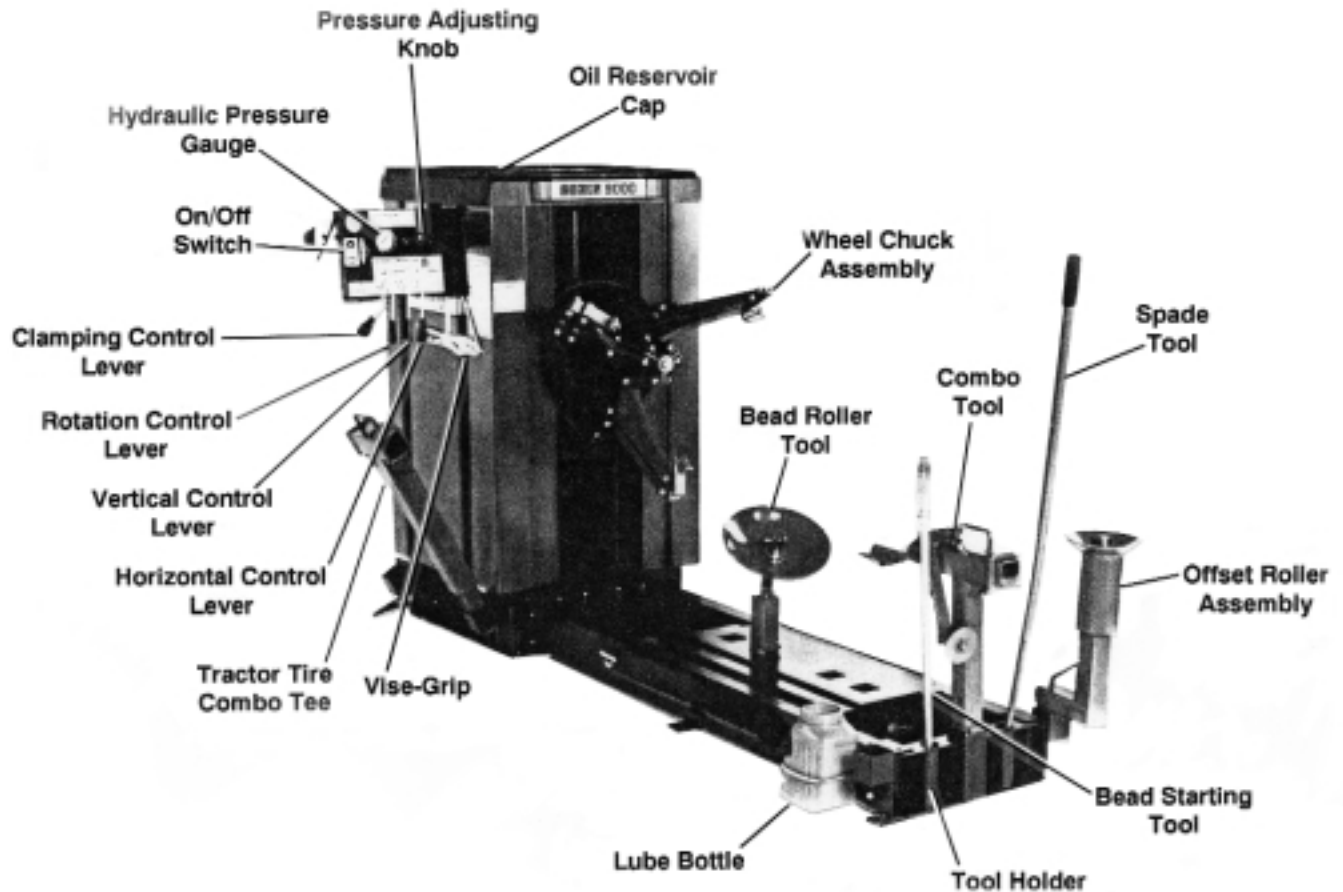

### Specifications

- Working Area:** 10 Foot Wide x 10Foot Long x 8 Foot Height
- Weight:** 1,600 Pounds
- Handles Tires:** Truck - 16 Inches to 24.5 Inches Tube-type and Tubeless  
Grader, Industrial and Farm - 16 Foot to 38 Inches
- Max. Tire Diameter:** 83 Inches
- Max. Wheel Diameter:** 44 Inches with Extensions

## Wheel Clamping

The self-centering chuck is powered by the high pressure hydraulic system to securely lock onto the wheel.

**Important:** The hydraulic pressure regulator knob, located on the swinging pod front, should normally be set to 1500 PSI. This pressure should be reduced when mounting or demounting weak or light weight wheels.

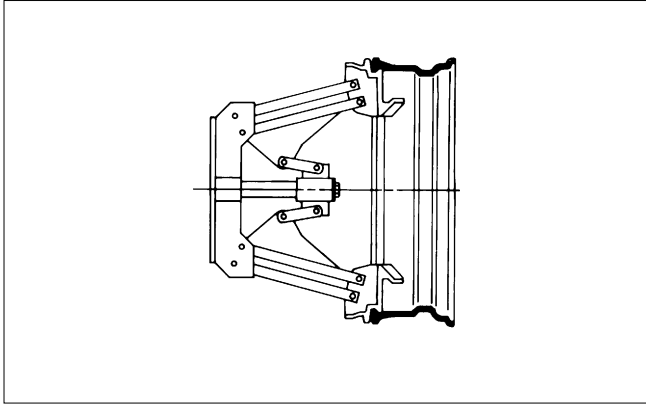

**1.** Roll the wheel onto the platform with the drop center (or the split ring) away from the chuck. Position the valve stem between two of the jaw clamps so the stem will not be damaged when the wheel is clamped.

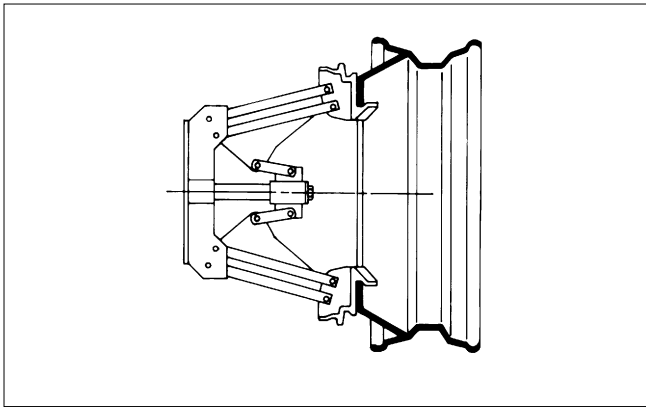

**2.** Rotate the chuck until one of the jaw clamps is in the 12 o'clock position.

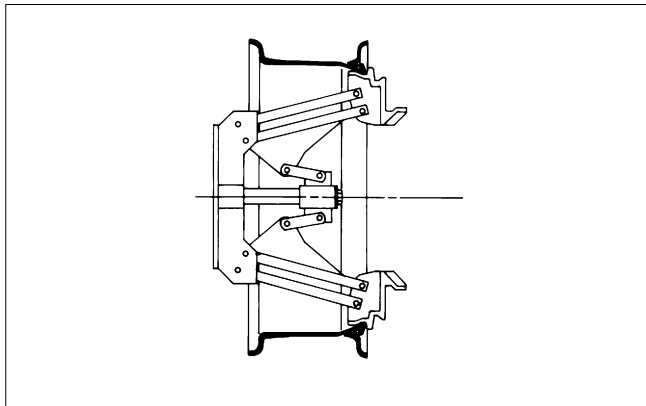

**3.** Open the jaw clamps slightly larger than the opening you are clamping, then move the jaw clamps up or down to the approximate center of the wheel. Refer to the wheel drawings on this page for suggested methods of clamping various types of wheels.

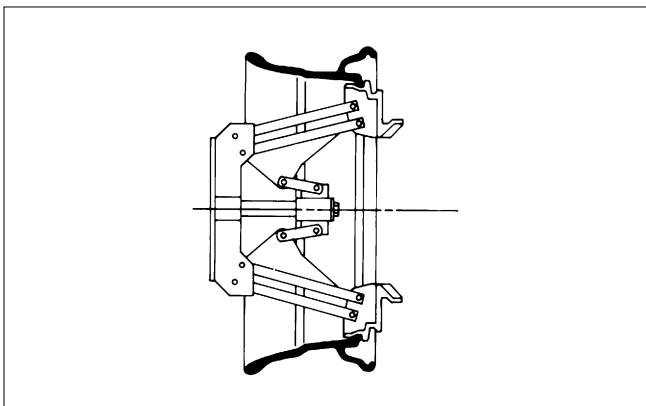

**4.** Lower the jaw clamps until you can position the wheel on the top jaw clamp. Raise the chuck, which will also raise the wheel off the platform.

**5.** Slowly retract the jaw clamps until the wheel falls into the proper position for clamping. Clamp the wheel by pulling the control lever toward you until the hydraulic motor stalls. Release the handle and the wheel is ready for mounting or demounting.



## Tubeless, Duplex, and Supersingle Tires

### Bead Loosening

**1.** After locking the wheel on the chuck, remove the valve core and deflate the tire completely.



**2.** Position the bead loosening disc in one of the square holes in the carriage closest to the outer edge of the tire.



**3.** Rotate the tire. While the tire is rotating, slowly advance the bead loosening disc to contact the tire bead. Adjust the chuck up or down so the disc is close to the rim.



**Do not contact the rim with the bead loosening disc. Damage to the rim may result.**

**4.** Once the rim edge is cleared, the chuck may be lowered to move the disc closer to the tire bead. Continue moving the disc toward the machine until the bead is loosened.



**5.** While the tire is still rotating, apply a liberal amount of tire lubricant to the tire bead and the rim.

**6.** Raise the chuck and back the tool away from the tire, being careful not to contact the rim.

**7.** Move the bead loosening disc to the rear of the tire and repeat the steps above to loosen the rear bead.

**Note:** Tire lubricant is very important in the demounting and mounting process. While the bead loosening tool is pushing the bead away from the rim edge, liberally lube both beads and the rim. **FAILURE TO APPLY LUBE COULD RESULT IN DAMAGE TO THE TIRE BEAD.**

**Note:** Applying a liberal amount of lube to the tire sidewall prior to bead loosening will make the tire more pliable and therefore reduce the likelihood of damage to the sidewall.

### Demounting

**1.** If the rim has an inclined edge of 15 degrees, continue the bead loosening procedure for the rear bead until the tire has been pushed off the rim.



**The bead opposite the disc must be in the drop center of the rim. Damage to the bead may occur if the bead is not in the drop center.**

**2.** If the rim has no edge, or has a stiff sidewall, retract the disc and remove it from the carriage. Place the combo tool and tee into position near the outer rim edge.

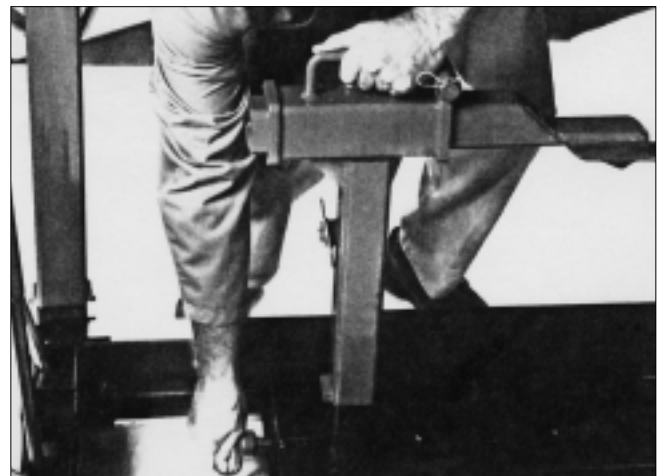

**3.** Install combo tool retaining pin into carriage.

# H.I.T. 9000



**4.** Tighten the locking handle and move the tool into position near the edge of the rim, as shown above.

**5.** Insert the bead lifting tool between the rim and bead at a point near the right side of the tool.



**6.** Pry the bead out over the rim. **Note:** You may have to assist the bead opposite the tool into the drop center. Use one of the tire tools to pry the top bead into the drop center.

**7.** Rotate the wheel counterclockwise while maintaining pressure on the bead lifting tool until the first bead is off.

**8.** Repeat the steps above for the rear bead.

**9.** Retract the tool and remove the tire.

## Mounting

**1.** LUBE BOTH BEADS LIBERALLY.

**2.** Roll the tire onto the carriage and lean it back against the rim.

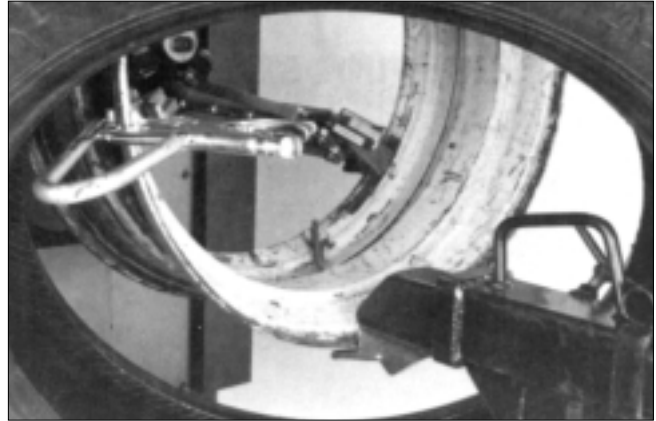

**3.** Position the combo tool near the edge of the rim as shown. **DO NOT CONTACT THE RIM.**

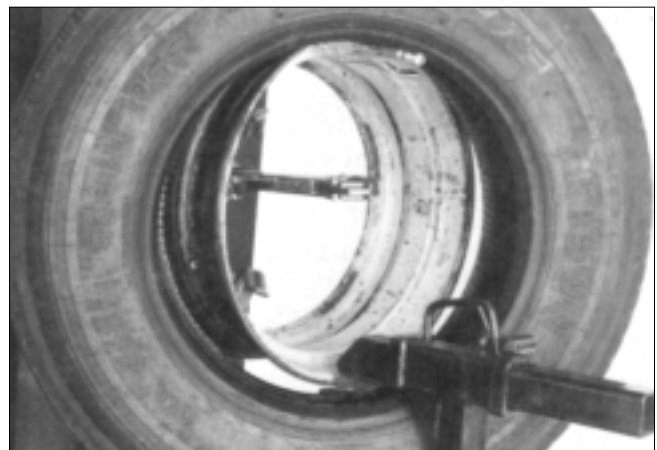

**4.** Securely clamp the vise grip to the rim edge at a position to the left of the combo tool. Rotate the chuck clockwise until the vise grip hooks the inner bead and lifts the tire.

**5.** Continue rotating the chuck until the first bead is mounted. **Avoid rotating the vise grip into the combo tool.**

**6.** Remove the vise grip and repeat the steps above to mount the outer bead.



**When mounting a tire, the bead must be started in the drop center of the rim. Failure to use the drop center could result in damage to the tire bead.**

**Note:** It may be necessary to push the bead(s) into the drop center during the mounting process.

**Note:** Tire lubricant greatly reduces the force needed to demount or mount a tire. Liberally lube each bead and rim edge while the bead loosener disc holds the bead away from the rim. **FAILURE TO APPLY LUBE COULD RESULT IN DAMAGE TO THE TIRE BEADS.**

## Wheels with Lock Rings

### Bead Loosening and Demounting

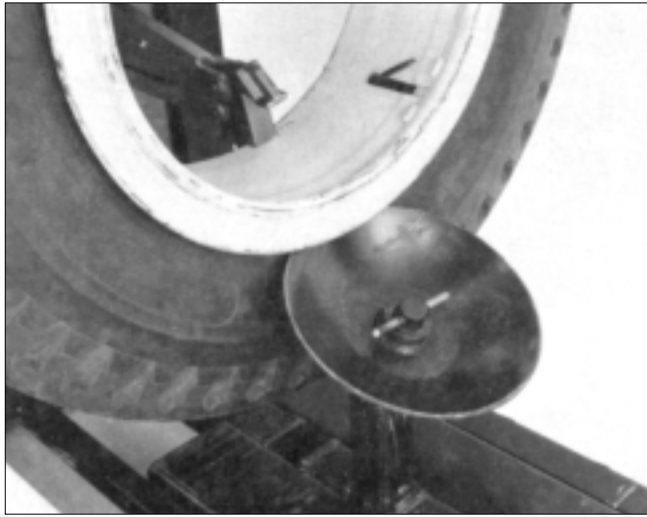

**1.** After chucking the wheel, position the bead loosener disc against the sidewall within 1/4 inch of the lock ring. **Do not contact the ring.**

**2.** Rotate the wheel and slowly advance the bead loosener disc until the bead is loosened. **LIBERALLY LUBE THE TIRE BEAD AND RIM.**



**3.** Use the ring tool to remove the lock ring(s).

**4.** Raise the tire and move the bead loosening disc into position on the inner bead. Do not contact the rim.



**5.** Rotate the wheel and slowly advance the disc to push the tire about half way off the wheel. Push the valve stem inside the wheel, then finish pushing the tire off the wheel.



**The tube will be damaged if the operator fails to push the valve stem into the wheel before completely removing the tire.**

### Mounting

**1.** Roll the tire onto the carriage, and align the rim to the center of the tire.

**2.** Liberally lube both beads and the rim. Slowly advance the carriage and guide the tire onto the rim. Stop about 1/3 of the way on and insert the tube.

**3.** Place the bead loosening disc in the carriage. Position it against the tire bead and push the tire onto the rim.

**4.** With the disc pushing on the outer sidewall, install the ring(s).

## Farm Tires

### Bead Loosening

**1.** Remove the valve core. Deflate the tire away from the machine and remove any calcium chloride or other substances from the tire prior to rolling the wheel onto the tire changer.



**2.** After locking the wheel on the chuck, move the bead loosening disc into position near the edge of the rim.

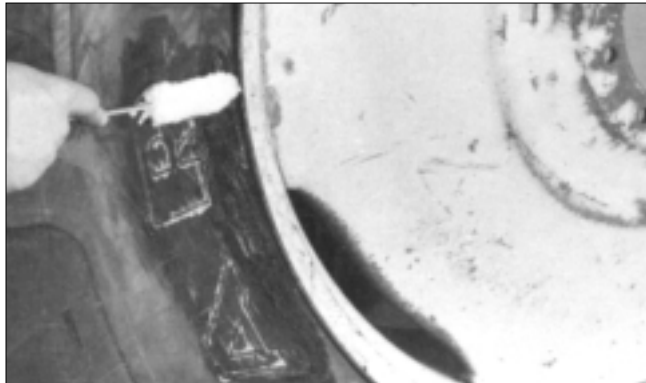

**Note:** Apply a liberal amount of lube to the tire sidewall. This will regain some of the original flexibility of the rubber, thus reducing possible damage to the sidewall.



**3.** Rotate the wheel and slowly move the bead loosening disc into the sidewall until the bead is loosened.

**4.** Continue to rotate the tire and apply a liberal amount of lube to the bead and the rim.

**5.** Move the bead loosening tool to the inner bead and repeat the above steps.

**Note:** Tire lubricant greatly reduces the force needed to demount or mount a tire. Liberally lube each bead and rim edge while the bead loosener disc holds the bead away from the rim. FAILURE TO APPLY LUBE COULD RESULT IN DAMAGE TO THE TIRE BEADS.

### Demounting

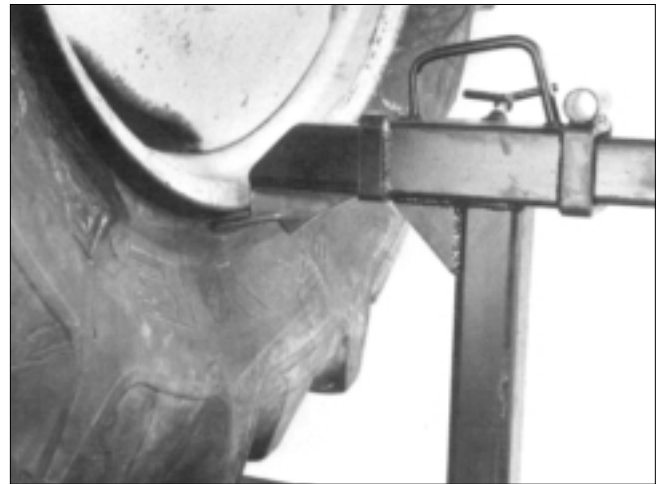

**1.** Advance the combo tool close to the rim, with the finger past the rim edge.



**2.** With the spade tool inserted between the rim and the outer bead, on the right of the combo tool, pry the bead out over the rim edge.

# H.I.T. 9000

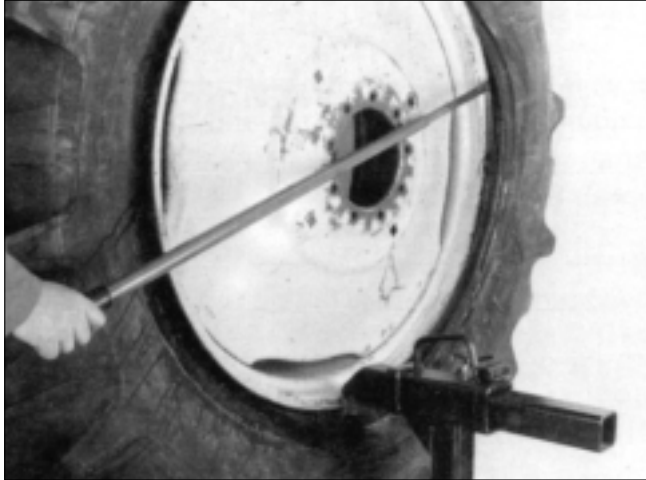

**3.** Rotate the wheel counterclockwise while maintaining pressure on the spade tool until the outer bead is demounted. Push the valve stem inside the rim and pull the inner tube out of the tire.

**Note:** It is possible to roll one or both beads(s) off the rim with the bead loosener disc instead of the combo tool. However, care must be taken not to damage the tube or the valve stem. By alternately rotating the wheel first counterclockwise, then clockwise, being careful not to pass over the valve stem, the tire may be demounted using this method. If the tire is wide, the rim is thin or weak, or the side wall is tough, do not use this method since the bead or the rim may be damaged.

**Note:** Tire lubricant greatly reduces the force needed to demount or mount a tire. Liberally lube each bead and rim edge while the bead loosener disc holds the bead away from the rim. FAILURE TO APPLY LUBE COULD RESULT IN DAMAGE TO THE TIRE BEADS.

## Mounting

- 1.** Lube both beads and the rim liberally.
- 2.** Rotate the rim so the valve stem hole is directly on the bottom, then roll the wheel onto the carriage.

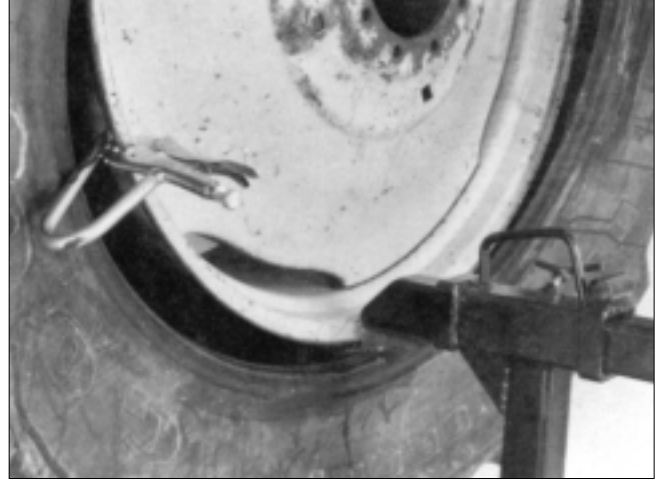

**3.** Move the combo tool into position near the edge of the rim.

**Note:** Mounting of the outer bead is shown in order to see the position of the tools. Position of the tools will be the same for the inner bead.

**4.** Lean the tire against the rim and clamp the vise grip on the edge of the rim to the left of the combo tool. Rotate the chuck to lift off the carriage.

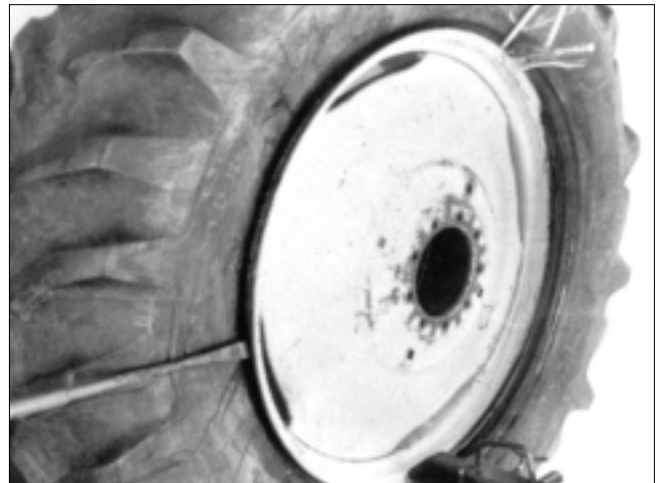

**5.** Using one of the tire tools to assist the bead into drop center, continue rotating the chuck until the inner bead is mounted.

**6.** Insert the inner tube and repeat the above steps to mount the outer bead.

**Note:** Avoid damage to the valve stem by never allowing the stem to pass the stationary tool.

# H.I.T. 9000

## Tire Spreading

There are two methods of spreading the tire with the roller tool.

### Method A:



**1.** With the first bead removed, hook the roller tool over the outer bead and move the tool away from the rim to spread the beads and gain access to the inside of the tire.

### Method B:

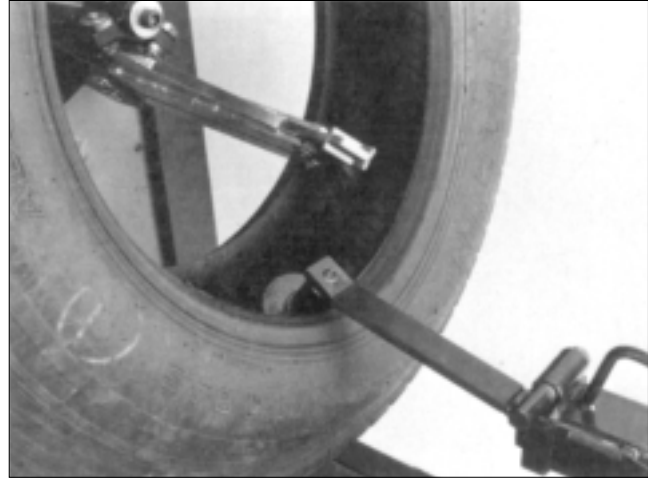

**1.** With the tire completely demounted and the rim removed from the clamps, hook the inner bead over the clamps and the roller tool over the outer bead. Move the tool away from the inner bead to gain access to the inside of the tire.

**Note:** The wheel can be rotated with the roller tool still in place, but the tool should be moved toward the wheel slightly. This will relieve some of the pressure on the bead, thus avoiding any damage, which might occur from over stretching the bead.



**Tire failure under pressure can be hazardous. Place the wheel inside an approved inflation chamber or cage before inflating. Use an approved remote inflation valve, hose, and gauge. ALWAYS wear safety goggles for eye protection. Do not stand beside the wheel or cage during inflation. Keep hands and other parts of the body out of the cage during inflation. Observe the tire pressure frequently. Do not exceed the manufacturer's recommended maximum inflation pressure. Failure to follow these instructions may cause the tire and rim to separate with tremendous force, resulting in serious injury or death.**

# H.I.T. 9000

## Maintenance

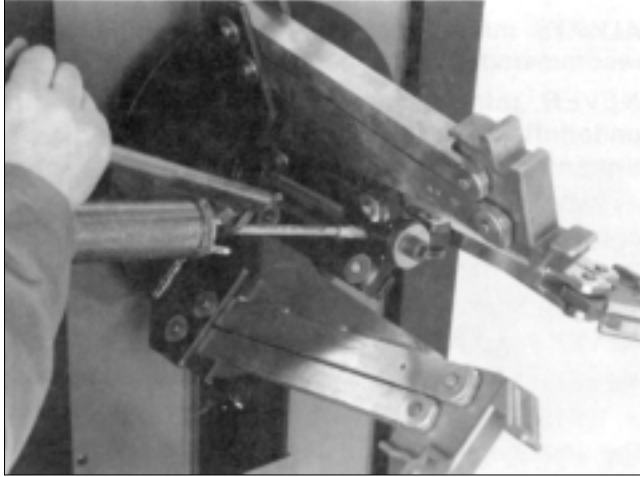

**1.** Using a grease gun and chassis grease, lubricate chuck hub bushing once every month.

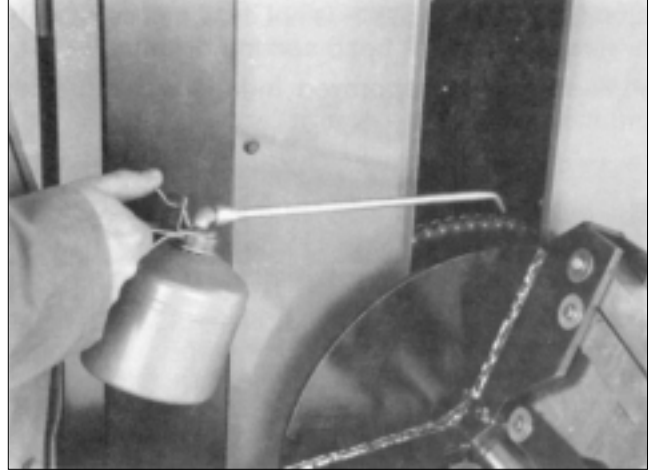

**3.** Using a grease gun and chassis grease, lubricate the disk shaft on the bead roller tube once every month.

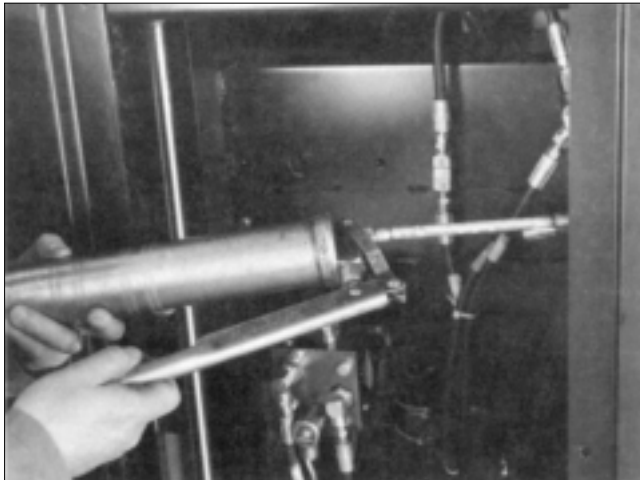

**2.** Remove the side panels and lubricate the four posts that guide the carriage up and down. Also, with a grease gun, lubricate the bushing sprocket tube. Lubricate these parts at least once every month.

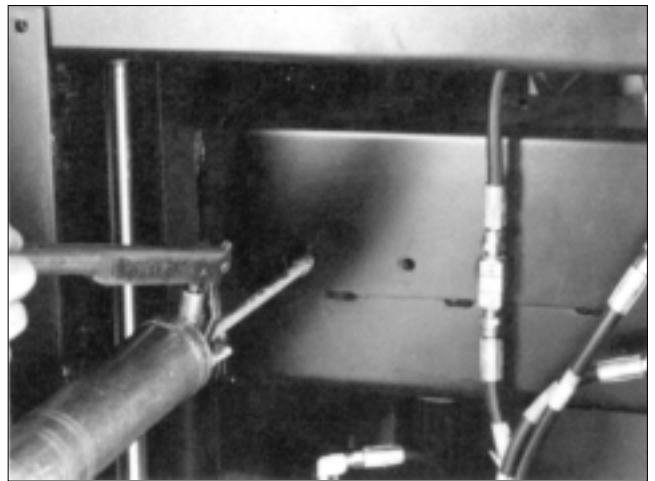

**4.** Grease chain and check the tension once every month and adjust if necessary.

**5.** Check hydraulic reservoir once every week. With all hydraulic cylinders retracted, the oil level should be approximately two inches below the top of reservoir. Add COATS® hydraulic oil (P.N. 8120454) to this level.

**6.** Change the oil filter once every six months. Screw off the filter and replace with service part number 8001631.

## **Truck Tire Changer Warranty Policy**

The COATS® Company warrants the H.I.T. 9000 Truck Tire Changer to be free of defects in workmanship and material for a period of twelve (12) months from the date of installation. Labor will be covered by the COATS® Company for a period of 90 days from the date of installation.

Upon inspection by COATS® Company or its authorized representative, any defect in workmanship and/or material within the warranty period will be:

Replaced in the field by the user, parts supplied free of charge by the COATS® Company, LaVergne, Tennessee, for the first 12 months of operation. Labor is covered by the COATS® Company for the first 90 days of operation.

This warranty is in lieu of all other warranties, expressed or implied, and of all other obligations and/or liabilities, and no person is authorized to make any other representation or assume any other obligation on behalf of the manufacturer.

This warranty shall not apply if damage is due to accident, negligence, alteration, abuse or misuse, worn parts, installation by unlicensed electrician, or has not been operated in accordance with the manufacturer's instructions for operation. Parts replaced under warranty will assume the remainder of the unit's warranty period. Only parts and accessories manufactured by the COATS® Company will be warranted as stated above and this warranty shall not apply to the tire changer or any parts thereof if parts and accessories not manufactured by COATS® Company are used as replacements for or in substitution of COATS® Company manufactured parts and accessories.

### **To validate warranty:**

- 1.** A licensed electrician must install all electrical requirements and sign the attached warranty registration card.
- 2.** The owner must fill out the post-paid warranty registration card and return it to COATS® Company within thirty (30) days of installation.

Failure to perform 1 above will void warranty coverage on electrical and hydraulic components. Failure to perform 2 may void entire warranty.

## **Service Policy**

Upon recognition of a problem, review the **Maintenance Instructions** and **Service Manual**.

If further assistance is required, call:

**(800) 688-6359**  
or  
**your nearest**  
**Hennessy Regional**  
**Office**

The COATS® Company will supply a replacement part-no charge- when it is determined by the factory or an authorized representative that the part is defective in workmanship and/or material and is covered by the warranty policy. The owner has the option to send the defective part to the COATS® Company for inspection, repair or replacement. All returns to the factory must be authorized by the COATS® Company prior to return. Freight to the factory will be paid by the owner. If the machine is serviced by COATS® authorized personnel, labor charges will be covered for a period of 90 days after the date of installation.