

# COATS®

## H.I.T. 5000

### Truck Tire Changer

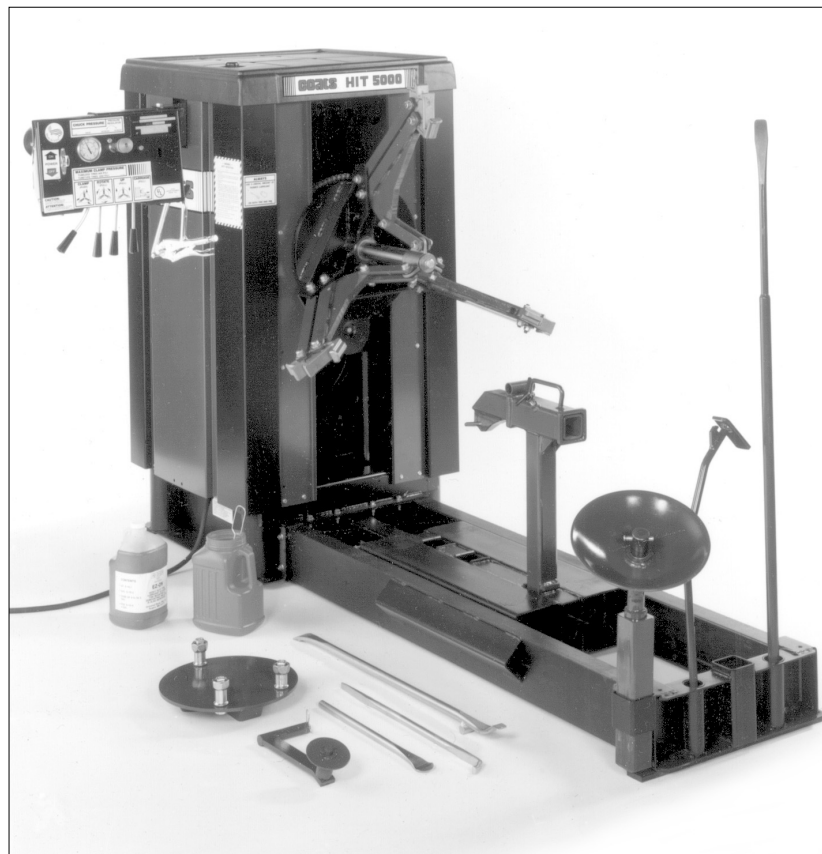

## *Parts Identification*

READ these instructions before placing unit in service KEEP these and other materials delivered with the unit in a binder near the machine for ease of reference by supervisors and operators.

**HENNESSY INDUSTRIES, INC.**

1601 J. P. Hennessy Drive, LaVergne, TN USA 37086-3565 615/641-7533 800/688-6359

HENNESSY INDUSTRIES INC. Manufacturer of AMMCO®, COATS® and BADA® Automotive Service Equipment and Tools.

Manual Part No.: 7109391 02

Revision: 02/08

# Parts Identification

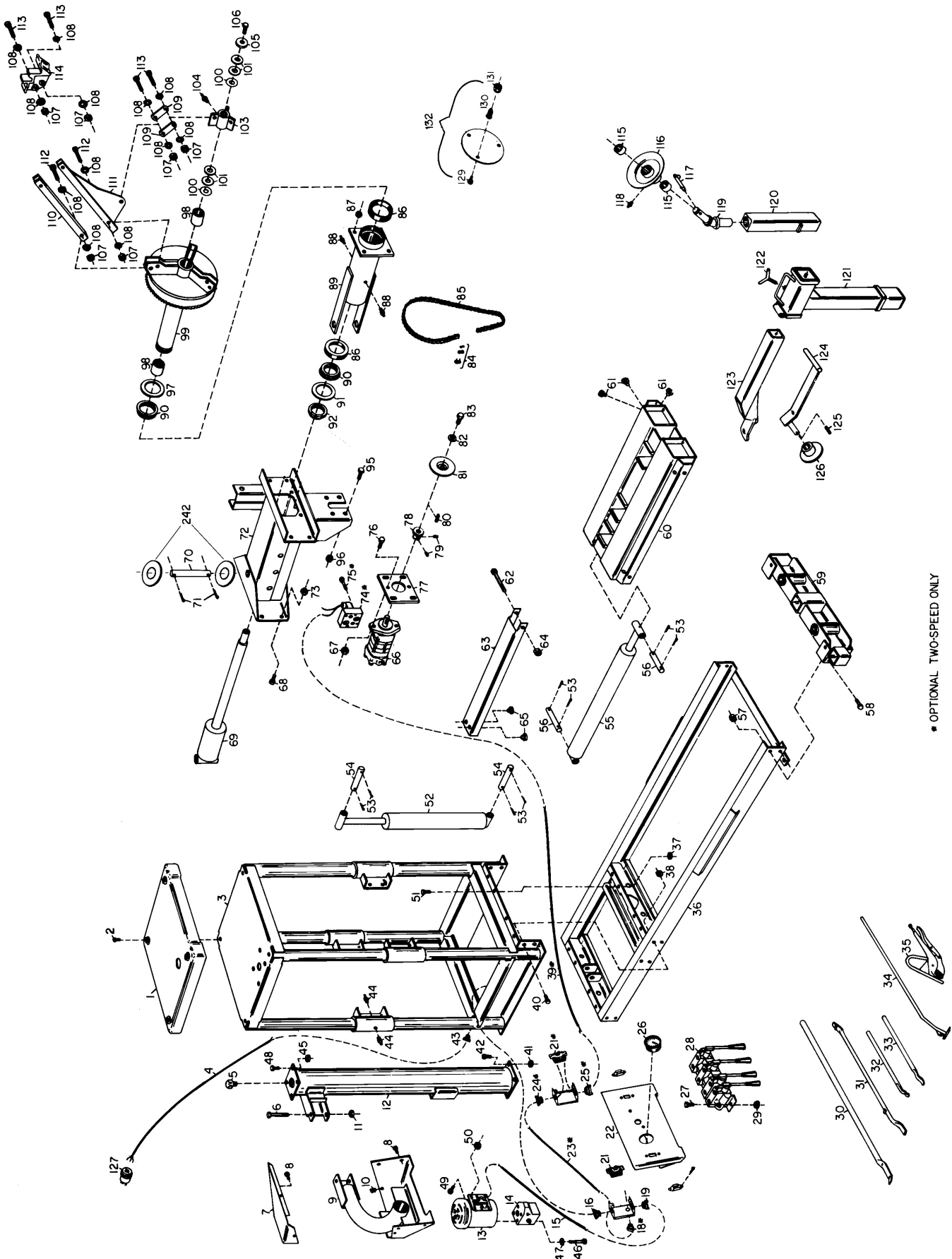

\* OPTIONAL TWO-SPEED ONLY

# Parts Identification

Ref	Part No.	Description	Ref	Part No.	Description
1	8109266	Plastic Top	57	8106303	3/8-16 Whiz Lock Nut
2	8106301	1/4" Hex Washer HD Self-Tap Screw	58	8110070	3/8-16 x 1-1/4 Self-Tap Bolt
3	8109111	Cage W/C	59	8109118	Front Bulkhead W/C
4	8109337	Power Cord 1Ph	60	8111085	Carriage W/C
4	8109595	Power Cord 3Ph	61	8109212	Carriage Rub Button
5	8120292	Breather Cap	62	8140882	3/8 x 3-3/4 HHCS
6	8109501	1/2-13 x 5-1/2 HHCS	63	8109208	Carriage Cylinder Cover
7	8109274	Pod Top	64	8301035	3/8-16 UNC Nylock Hex Nut
8	8106301	1/4" Hex Washer HD Self-Tap Screw	65	8109350	Rub Button
9	8109119	Pod W/C	66	8108975	Hydraulic Motor Single-Speed
10	8106304	1/4" Tinnerman	67	8109385	Hydraulic Motor Two-Speed
11	8120458	1/2-13 Hex Lock Nut	67	8301122	1/2-13 UNC Nylock Hex Nuts
12	8109115	Reservoir W/C	68	8106302	3/8-16 x 7/8 Ser Wash HD Screw
13	85008941	Electric Motor 1 Ph	69	8109122	Clamp Cylinder
13	85008942	Electric Motor 3 Ph	70	8109280	Pin Chuck Cylinder
14	8108969	Hydraulic Pump	71	8107139	Hitch Pin
15	8109338	Cord Motor 1 Ph	72	8109147	Torque Box W/C
16	8150128	Cable Connector	73	8106303	3/8-16 Whiz Lock Nut
18	8150128	Cable Connector	74	8109351	Two-Speed Motor Block
19	8150128	Cable Connector	75	8109352	3/8 x 2-1/4 NF HHCS
21	8109339	Switch 1 Ph	76	8120063	1/2-13 x 1-3/4 Ser Washer HD Screw
21	8110184	Switch 3 Ph	77	8109224	Hydraulic Motor Mounting Plate
22	8109199	Pod Front	78	8109234	Sprocket Small
23	8109340	Cord - Two-Speed Switch	79	8180217	5/16-18 x 3/8" SHCS Gr5
24	8150128	Cable Connector	80	8109353	Key
25	8150128	Cable Connector	81	8109273	Guard Drive Sprocket
26	8109226	Pressure Gauge	82	8301032	3/8 Flat Washer, Zinc Plate
27	8120325	Bolt 5/16-1" 18 NC	83	8109354	3/8 x 3/4 HHCS
28	8108977	Hydraulic Control Valve	84	8109355	Master Link
29	8181183	5/16-18 Nylon Insert Lock Nut, Gr.5	85	8109356	Chain
30	8120334	Spade Tool	86	8109172	Outer Bearing Race
31	8109342	Tire Iron Lock Tubeless	87	8301122	1/2-13 UNC Nylock Hex Nuts
32	8109343	Tire Iron Lock Ring	88	8109348	Grease Fitting
33	8109344	Tire Iron Drop Center	89	8109173	Bearing Housing W/C
34	8109345	Bead Starting Tool	90	8109162	Inner Bearing Race
35	8109346	Vise Grip	91	8109124	Washer Chuck Pivot
36	8109110	Frame W/C	92	8109131	Spanner Nut
37	8106303	3/8-16 Whiz Lock Nut	95	8120063	1/2-13 x 1-3/4 Ser Washer HD Screw
38	8106303	3/8-16 Whiz Lock Nut	96	8301122	1/2-13 UNC Nylock Hex Nuts
39	8109337	Cord - Two-Speed Motor Block	97	8109124	Washer Chuck Pivot
40	8110070	3/8-16 x 1-1/4 Self-Tap Bolt	98	8111657	Bushing Sprocket Tube
41	8106303	3/8-16 Whiz Lock Nut	99	8109164	Chuck-Sprocket Tube W/C
42	8120472	3/8 x 2 HHCS	100	8109294	Shim Clamp Spider .015
43	8150128	Cable Connector	101	8109295	Shim Clamp Spider .030
44	8109348	Grease Fitting	102		
45	8106303	3/8-16 Whiz Lock Nut	103	8109116	Clamp Actuator w/Assembly
46	8109349	5/16 x 3-1/4 HHCS	104	8109348	Grease Fitting
47	8120421	5/16 Lock Washer	105	8109210	Washer Front Clamp Spider
48	8106302	3/8-16 x 7/8 Ser Wash HD Screw	106	8109357	5/8" x 1 HHCS
49	8106302	3/8-16 x 7/8 Ser Wash HD Screw	107	8301121	Chuck Washer
50	8106303	3/8-16 Whiz Lock Nut	109	8108974	Link Cylinder Pivot
51	8106302	3/8-16 x 7/8 Ser Wash HD Screw	110	8108970	Link Clamp
52	8108966	Vertical Cylinder	111	8109117	Clamp Strut w/Assembly
53	8103006	Cotter Pin	112	8109307	Bolt Chuck Face
54	8109276	Pivot Pin Cylinder	113	8109308	Bolt Chuck Claw
55	8108967	Carriage Cylinder	114	8110829	Jaw Clamp
56	8109276	Pivot Pin Cylinder	115	8109287	Bushing Disk
			116	8109288	Disk W/C

ITEMS NOT SHOWN:

Ref	Part No.	Description
133	8110852	Offset Roller
135	8110841	Carriage Lock Pin
136	8110652	Earth Mover Bead Loosener Shaft

Ref Part No.	Description
201	Hose Filter to Reservoir
202	Hose Clamp
203	Fitting
204	Hose Reservoir to Pump
205	Hose Pump Pressure Relief
206	Hose Pump to Valve
207	Clamping Hose Valve (Rear)
208	Clamping Hose Valve (Front)
209	Hose Valve to Chuck Valve
210	Adapter Fitting
211	Hose - Gauge
212	1/4-20 x 3/4 Hex Hd Cap Scr Gr.5
213	Check Valve Block
214	Hose Check Valve Block to Filter
215	Hose Clamp Cylinder Rear
216	Filter Element
217	Reducer
218	Filter Head
219	1/4" Hex Washer HD Self-Tap Screw
220	90° Tube Fitting
221	Hose Clamp Cylinder (Front)
222	Vertical Cylinder Hose Top
223	Vertical Cylinder Hose Bottom
224	Carriage Cylinder Hose (Rear)
225	Carriage Cylinder Hose (Front)
226	90° Fitting
227	Hose Hydraulic Motor
228	Hose Hydraulic Motor
229	Hose Hydraulic Motor to Filter
230	Reducer
231	Two-Speed Motor Block
232	Corner Panel Side
233	Panel Rear
234	Panel Side Operator Side
235	1/4" Hex Washer HD Self-Tap Screw
236	Front Panel Operator Side
239	Front Panel Opposite Operator Side
240	Panel Side Opposite Operator
241	Tinnerman
244	1/2" NPT x 1/2" Hose Fitting
245	3/4 - 1/2" Strainer
246	Hydraulic Tee 1/4" NPT
247	Hydraulic Nipple 1/4" NPT x 4" Lg
248	Hydraulic Nipple 1/4" NPT x 2" Lg
249	Adapter 1/4 NPT/#6 SAE Ftg
250	Accumulator

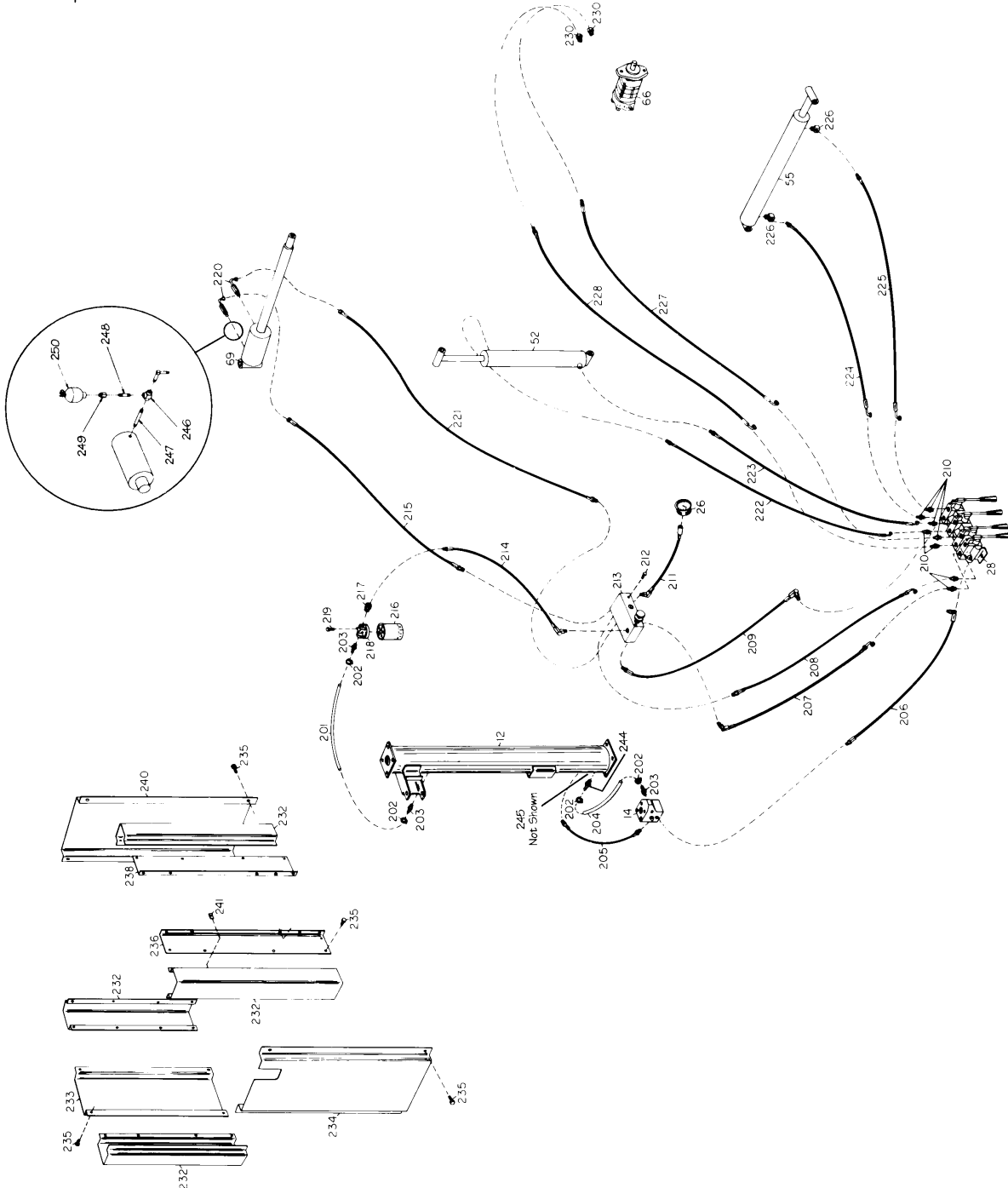

When ordering parts always give the following information:  
 (1) Part Number (2) Description (3) Serial Number of Your Machine