

# COATS®

## Electro-Hydraulic Tire Changer For Medium and Large Size Tires

### **CHD-9043**

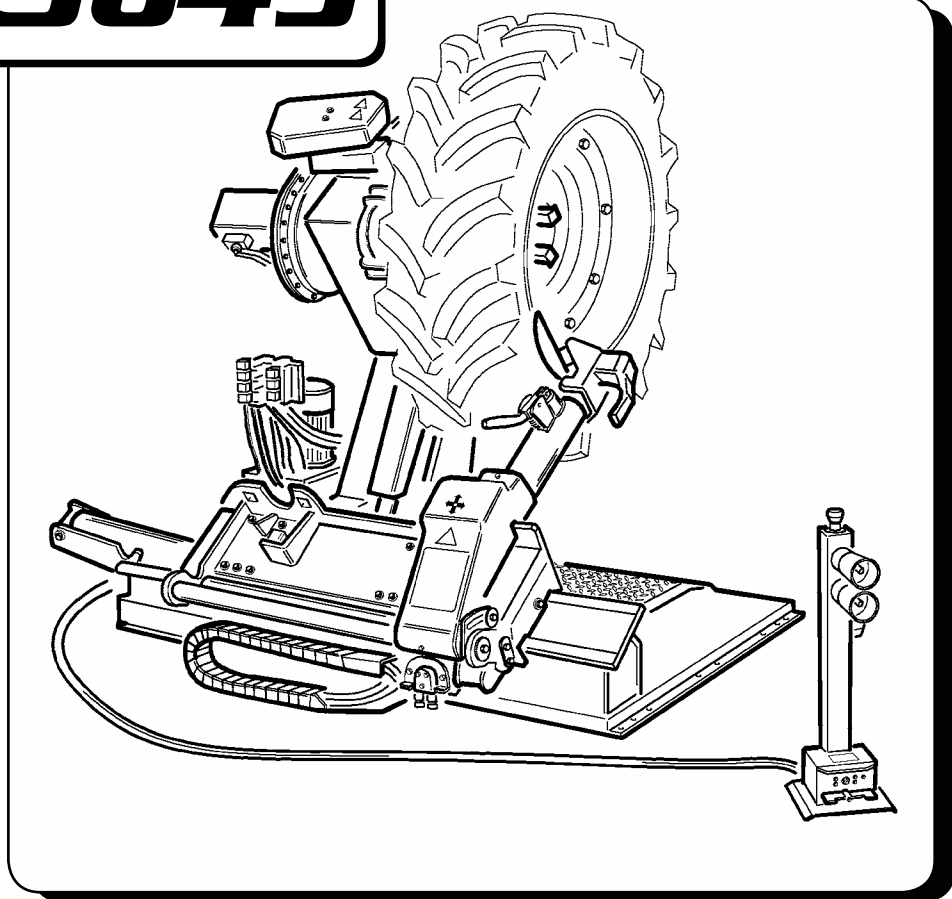

### ● OPERATING AND MAINTENANCE INSTRUCTIONS

READ these instructions before placing unit in service KEEP these and other materials delivered with the unit in a binder near the machine for ease of reference by supervisors and operators.

# INDEX

<b>1 - GENERAL INFORMATION.....</b>	<b>3</b>
<b>2 - TECHNICAL DATA.....</b>	<b>3</b>
<b>3 - GENERAL SAFETY REGULATION.....</b>	<b>3</b>
<b>4 - SAFETY DEVICES.....</b>	<b>3</b>
<b>5 - TRANSPORT.....</b>	<b>4</b>
<b>6 - UNPACKING.....</b>	<b>4</b>
<b>7 - INSTALLATION .....</b>	<b>4</b>
7.1 Installation place.....	4
7.2 Workplace requirements.....	5
7.3 Electric hook up.....	6
Sense of rotation check	
<b>8 - LAYOUT OF FUNCTIONAL PARTS.....</b>	<b>7</b>
<b>9 - IDENTIFYING WARNING SIGNALS.....</b>	<b>8</b>
<b>10 - IDENTIFICATION OF CONTROL.....</b>	<b>9</b>
<b>11- WORKING POSITION.....</b>	<b>9</b>
<b>12 - CORRECT OPERATION CHECKS.....</b>	<b>9</b>
<b>13 - OPERATION.....</b>	<b>11</b>
13.1 Rim clamping.....	11
Light-alloy rim clamping	
13.2 Tubeless and supersingle tires.....	12
Bead loosening	
Demounting	
Mounting	
13.3 Tubed tires.....	17
Bead loosening	
Demounting	
Mounting	
13.4 Rims with split ring.....	20
Bead loosening and demounting	
Mounting	
<b>14 - ORDINARY MAINTENANCE.....</b>	<b>24</b>
<b>15 - TROUBLE SHOOTING.....</b>	<b>24</b>
<b>16- MOVING THE MACHINE.....</b>	<b>25</b>
<b>17- STORING.....</b>	<b>25</b>
<b>18- SCRAPPING A MACHINE.....</b>	<b>25</b>
<b>19- DATA ON SERIAL PLATE.....</b>	<b>26</b>
<b>20- ACCESSORIES.....</b>	<b>26</b>

# 1 GENERAL INFORMATION

This tyre changer has been specifically designed to demount and mount truck, bus and commercial van tires, with rims from 14" to 56" and a **maximum 90" (2.300) mm diameter**.

Any other use is improper and therefore not authorized. Before beginning any kind of work on or with this machine, carefully read and understand the contents of these operating instructions.

**The Manufacturer** shall not liable for any injury to persons or damage to things caused by improper use of this machine.

**KEEP THIS MANUAL NEAR THE MACHINE AND CONSULT IT AS NEEDED DURING OPERATIONS.**

# 2 TECHNICAL DATA

Electric Power requirement	220V - 3 PH - 60Hz 15 Amp
Pump motor	1.1 kw
Gear-box motor	1.3 / 1.8 kw
Handles rim from	14" - 56"
Max. wheel diameter	2,300 mm
Max. wheel width	1,065 mm
Max. wheel weight	1,500 kg
Weight (with standard accessories)	770 Kg
Acoustic pressure level (at work)	LpA <70 dB (A)

# 3 GENERAL SAFETY REGULATIONS

The use of this machine is reserved to specially trained and authorized personnel.

Any unauthorized changes or modifications to the machine, in particular to its electric system, relieve the manufacturer from all liability. Removing or tampering with the safety devices installed on this machine is in violation of European Safety Regulations.

**Any work, however minor, on the electric system must be done exclusively by professionally qualified personnel.**

# 4 SAFETY DEVICES

The tyre changer has a number of safety devices designed to guarantee the utmost operator safety:

**1. Check valve on the spindle opening hydraulic line** (inside the swivel connector, see fig. B/1). This prevents the wheel from falling from the spindle if the hydraulic line is accidentally broken.

**2. Pressure relief valve factory set at 1,885 PSI (130 bar) ±10%** (See Fig. B/2).

This limits the pressure in the hydraulic circuit and ensure correct operation of the plant.

**3. Pump motor overload cut-out** (inside the electric enclosure).

This cuts in if the motor overheats to prevent it from burning out.

**4. Check valve on the chuck arm lifting hydraulic line.** It prevents the chuck arm from descending when any accidental break occurs in the hydraulic circuit.

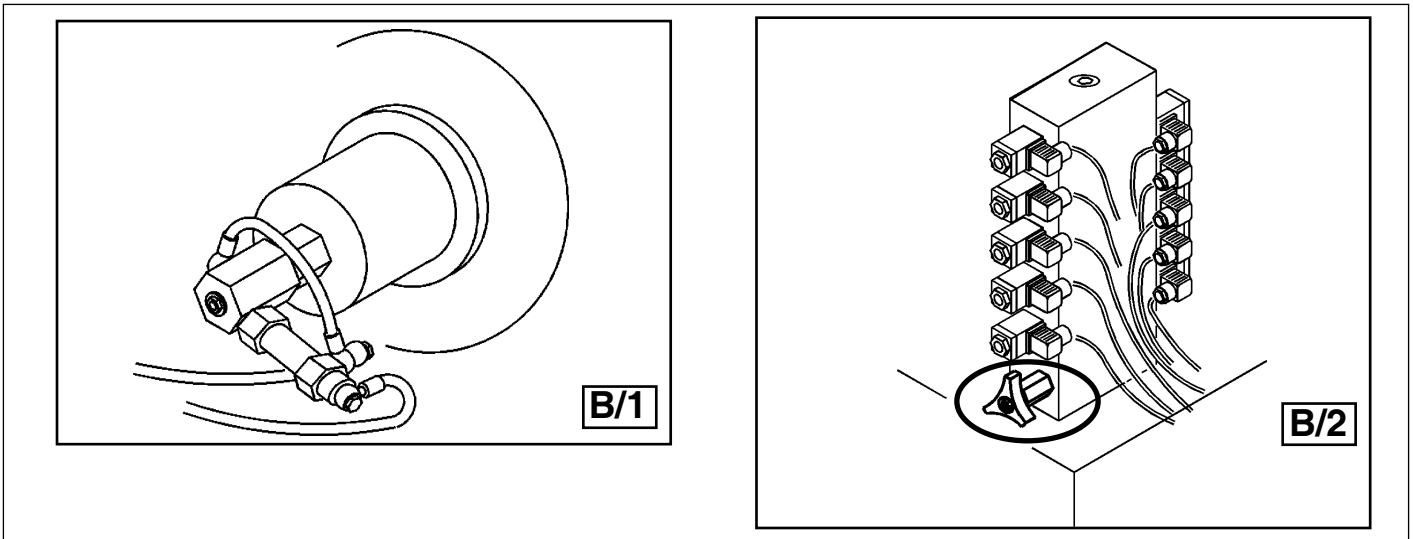

## 5 TRANSPORT

The machine is delivered in:  
1- in a wooden crate with pallet

The machine must be handled with a fork-lift truck with the forks positioned as shown in the figure A/2.  
Shipping weight for the machine is 2083 lbs (945 kg.)

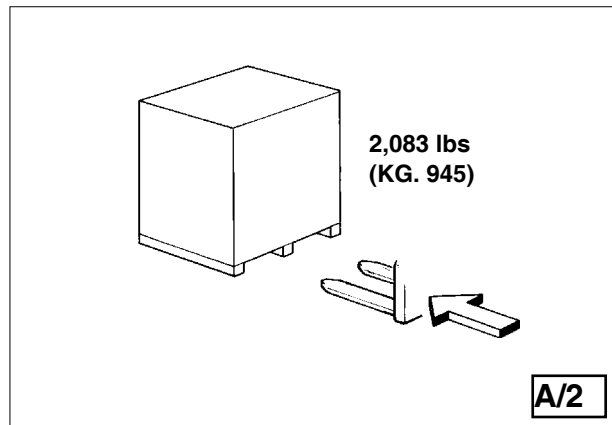

## 6 UNPACKING

Once the packing material has been removed, check the machine visually for any signs of damage.  
Keep the packing materials out of the reach of children as they can be a source of danger.  
**N.B.: Keep the packing for possible future transport.**

## 7 INSTALLATION

### 7.1 INSTALLATION PLACE

Choose the place the machine is to be installed in compliance with current work place safety regulations. The floor should not be broken or uneven so that the machine will be stable and the platform rollers can move freely.  
If the installation is outdoor, it must be protected by some kind of roofing against rain.  
The following work environment conditions are applicable:  
Relative humidity: from 30-95% without condensation;  
Temperature: from 32°-131° F (0-55° C).



**ATTENTION!**  
The machine must not be operated in explosive atmospheres.

**WORK PLACE REQUIREMENT**

Maximum machine space requirements are 88.2X6.3 inches (2,240x 1,640 mm) with a minimum distance from walls as shown in the diagram.

**CAUTION!** These measurements are also the fire changers working range. Persons other than specially trained and authorized operators are expressly forbidden to enter this area.

Position the tire changer lifting it with the specific bracket (1, Fig. A) with the tool carrier arm (2, Fig. A) lowered all the way, the spindle (3, Fig. A) closed and the tool carrier slide (4, Fig. A) at its stop close to the arm.

The mobile control unit has no fixed position, but it must be positioned in a way that the user can observe the machine when working

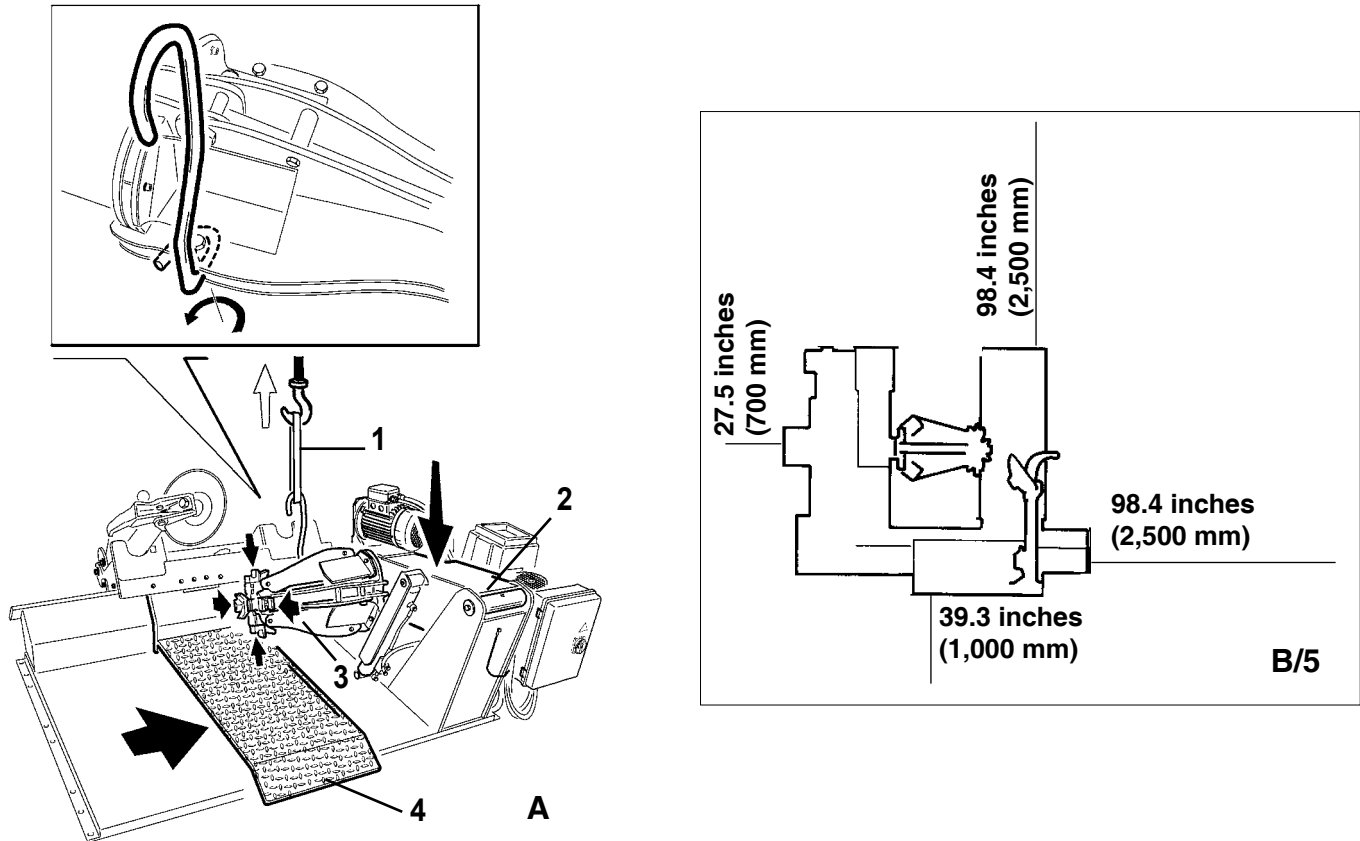

The tire-changer must be installed on a levelled concrete floor at least 8" (20 cm) . thick, with a minimum concrete quality of B25 in accordance with DIN 1,045 requirements (foundations).

For your reference see the side drawing as well as the table herebelow.

	Foundations dimensions inch (cm).			Concrete quality	Min. pressure resistance
	Length	Width	Thickness		
<ul style="list-style-type: none"> <li> Ground</li> <li> Reinforced concrete</li> <li> Electrowelded grid</li> <li> Pebble gravel</li> </ul>	78,74 (200)	64,5 (164)	5,9 (15)	B25	937 lbs/sqft (425 Kg / cm <sup>2</sup> )

If a floor of this type is not available on site, fastening points of the specified concrete quality are acceptable.

The surface, on which the universal tire-changer is to be installed, must be flat and well levelled in all directions.

Inclinations up to 0.25% relative to the horizontal can be compensated using suitable shims, wedges or alike.

**When working with wheels, whose weight is higher than 2,204 lbs (1,000 kg)., it is necessary to fasten the tire-changer to the floor by means of proper anchor bolts.**

By means of a Widia bit Ø 16 drill a 0.630 inch hole (130 mm) into the floor passing through the holes provided on the base frame.

If there is an additional floor covering (B), or if shims or wedges are necessary for levelling (C), longer anchor bolts must be used.

Place an anchor bolt into each hole.

Make sure the anchor bolts extend at least 4.90" (125 mm). into the concrete slab, as indicated in the drawing.

Tighten the anchor bolts completely.

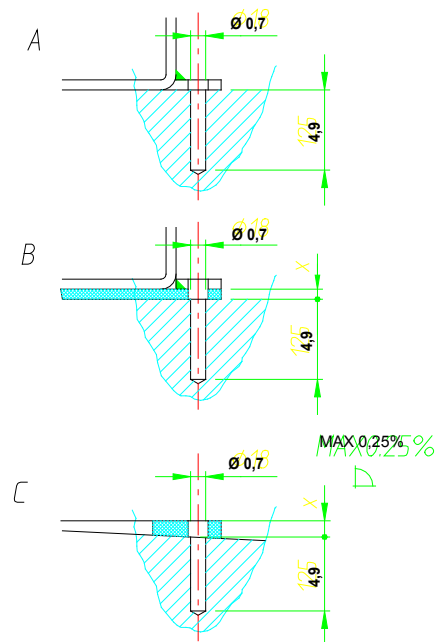
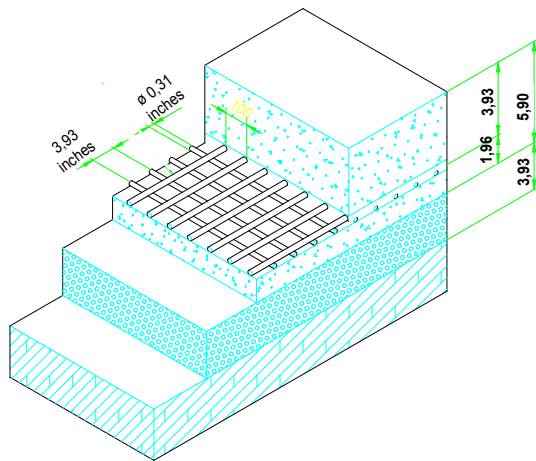

**7.3 ELECTRIC HOOK UP**

Before making any electric hook up, check to be certain that the main voltage corresponds to that stamped on the voltage tag (attached to the cord near the tire changer's plug).

It is absolutely essential that :

- The system is equipped with a good grounding circuit.
- The current intake is adequately protected against overcurrents with fuses or automatic magneto-thermic switch.

Note the required power draw as highlighted on the data plate fixed to the tire changer. Check to make sure the shop electric wiring circuit is dimensioned sufficiently to carry this.



**Work on the electric system, even if minor, must be done exclusively by professionally qualified electrician.**

Manufacturer shall not be liable for any injury to persons or damage to things caused by failure to comply with these regulations and can cancel warranty coverage.

**SENSE OF ROTATION CHECKS**

Connect the machine to the mains, switch "ON" (5, fig. B/7) and check that the gearbox motor rotation corresponds to the indicating arrow (6, fig. B/6).

If not, switch two wires in the plug .

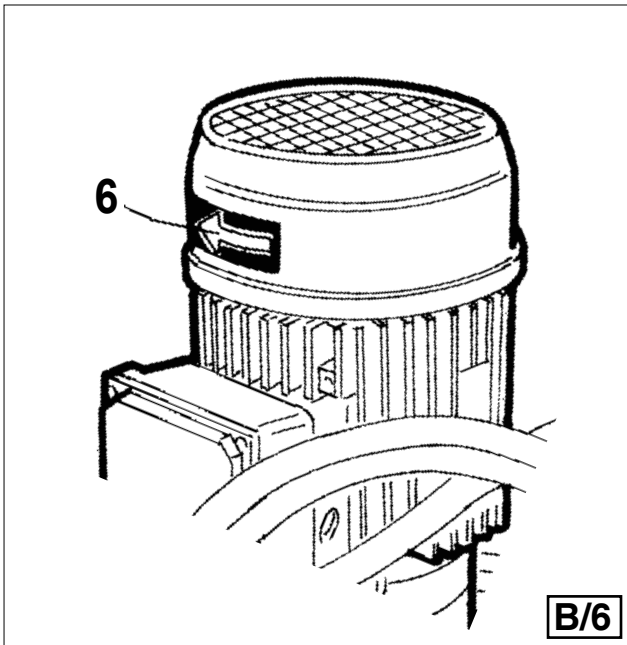

B/6

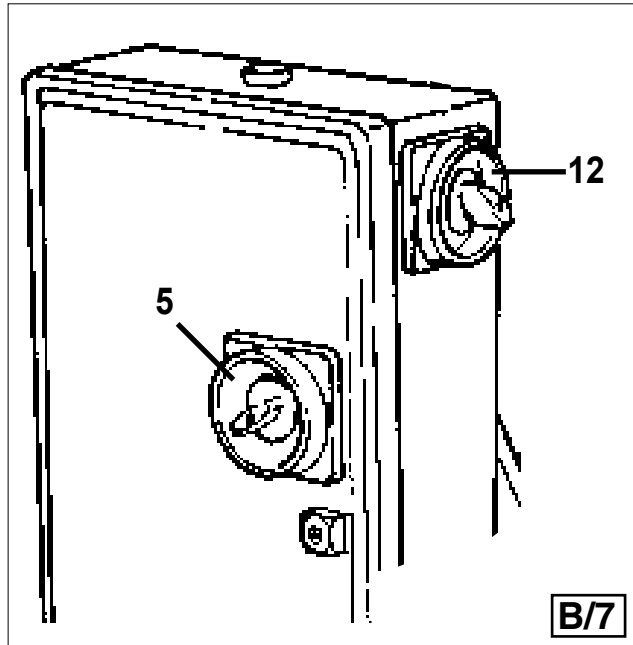

B/7

## 8 LAYOUT OF FUNCTIONAL PARTS

- 1 - Lifting bracket
- 2 - Self-centering chuck holding arm
- 3 - Self-centering chuck
- 4 - Sliding ramp
- 8 - Handler
- 9 - Switch
- 10 - Pedal
- 11 - Handler
- 13 - Carriage
- 14 - Tool holding arm
- 15 - Arm lever
- 17 - Bead breaking disk
- 18 - Tool
- 22 - Jaw



**WARNING!**  
 During all operations, keep hands and other parts of the body as far as possible from moving parts of the machine. Necklaces, bracelets and too large clothes, can be dangerous for the operator.

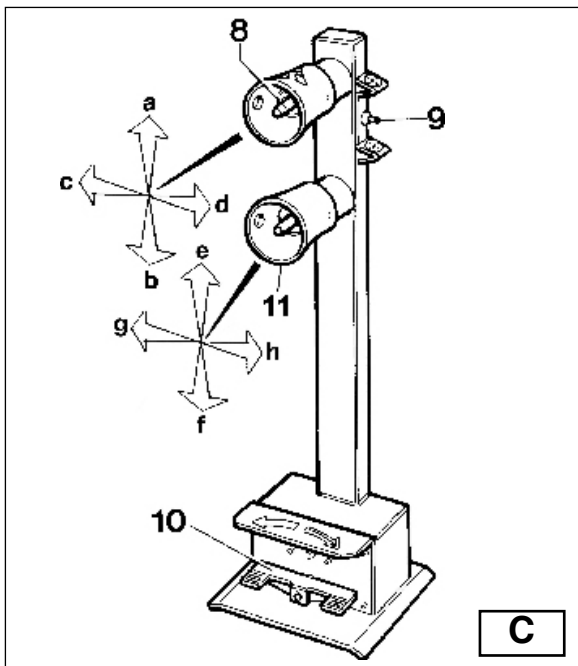

C

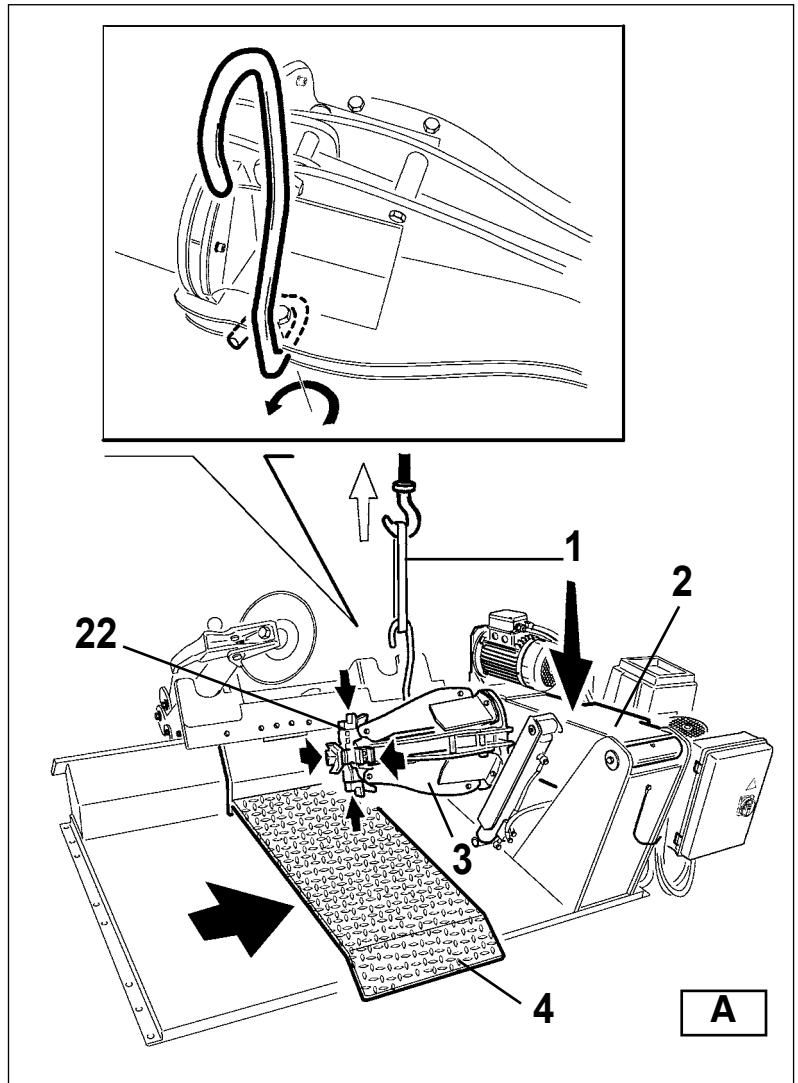

A

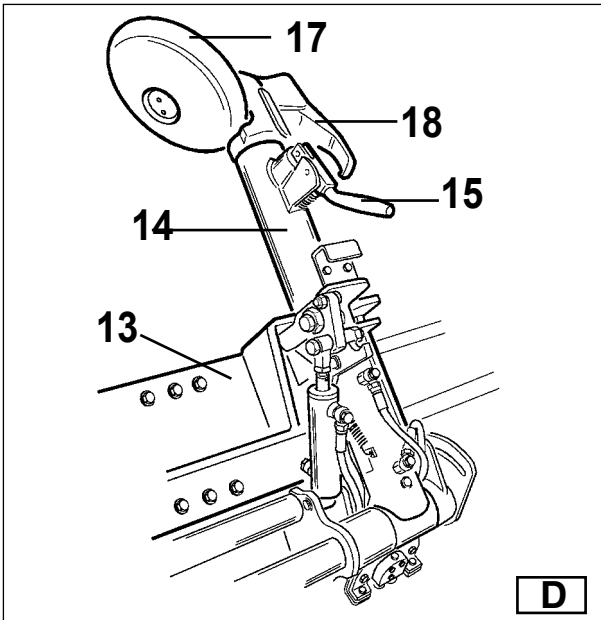

## 9 IDENTIFYING WARNING SIGNALS



**WARNING:**

Unreadable and missing warning labels must be replaced immediately.  
Do not use the tire changer if one or more labels are missing.

Do not add any object that could prevent the operator from seeing the labels.  
Use ref. code # 2019113 to order labels set, if needed

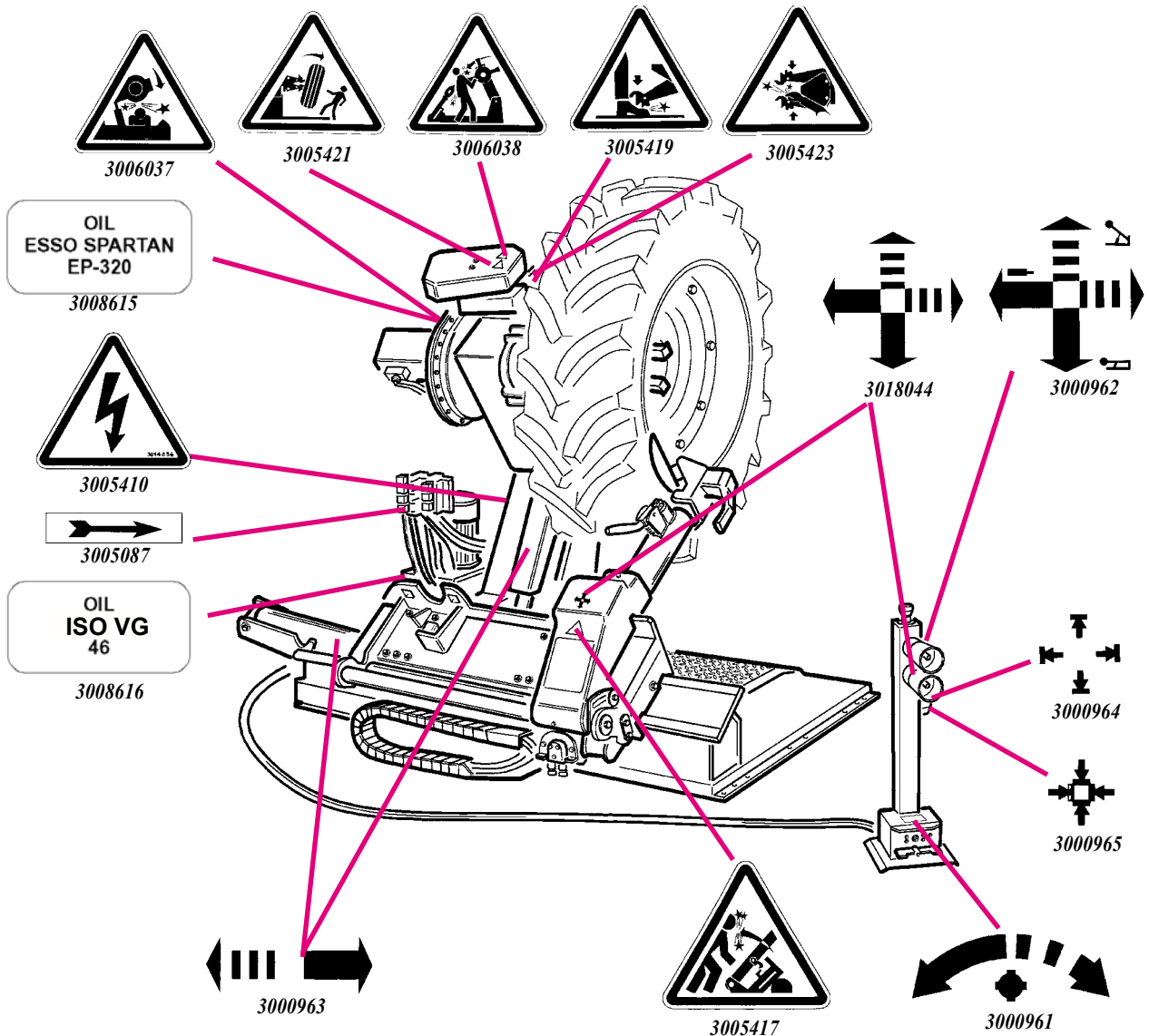



## 10 IDENTIFYING CONTROLS

The mobile control centre (fig. C) enables the operator to work at any position around the machine. On this mobile control centre the following controls are located:

-**The lever (8, fig. C)** which in position (a) lifts the chuck arm and in position (b) lowers it; in position (c) moves the tool holder arm and the sliding table towards the self-centering chuck and in position (d) moves them away.

Note: in order to memorise this operation, there is a hole in the lever guard corresponding to position c.

- the lever (11, fig. C) which in position (e) releases and tilts the tool and in position (f) locks the tool bringing it back to working position; in position (g) moves the tool carriage leftwards and in position (h) moves it to the opposite side.

-**The chuck switch (9, fig. C)** when moved upwards, opens the arms of the self-centering chuck (LOCKING), and when moved down, closes the arm of the self-centering chuck (UNLOCKING).

-**The pedal (10, fig. C)** when pressed on the left or right side rotates the self-centering chuck in the same direction as shown by the arrows placed on the foot pedal.

Both rotations can be made with two different speeds, just placing the selector (12, fig. B/6) in position 1 for getting slow rotation and in position 2 for fast rotation of the turntable

The tire changer also has:

**Handle (15, Fig. D)** to tip the tool carrier arm (14, Fig. 4) from its work to its non-working position and vice-versa.

Pressing the **emergency stop button** (12, fig. C) will stop any operation in course.

## 11 WORKING POSITION

The diagram B/8 illustrates the various working positions (A,B,C,D) referred to in the following pages describing how to use the tire changer. Use of these positions ensures greater precision, speed and safety for those using the machine.

## 12 CORRECT OPERATION CHECKS

Before using the ti

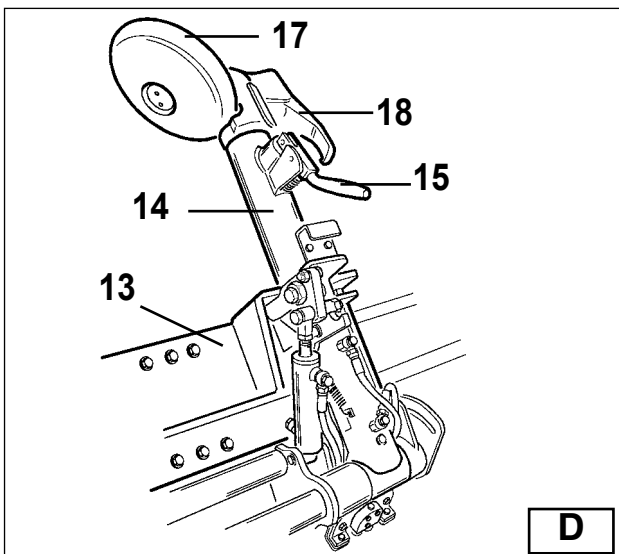
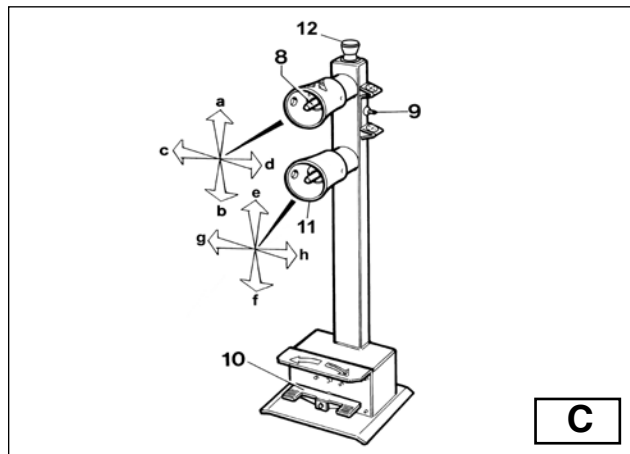
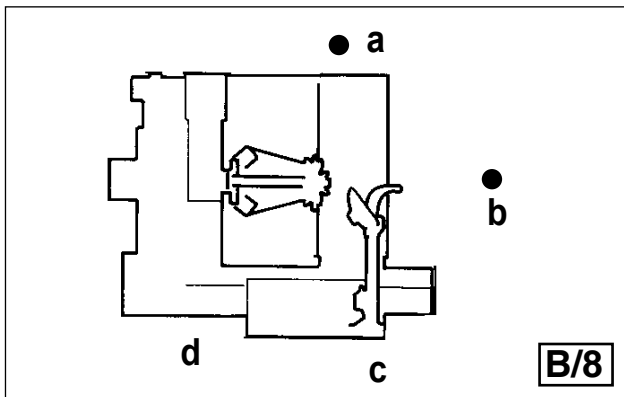

First use handle (15, Fig. D) to tip the arm to this position.



**CAUTION!**

Do not move your face close to the tool carrier arm when you release it to tip it as needed.

1) Move the joystick (8, Fig. C) up (a): the spindle carrier arm (2, Fig. A) should lift; move the joystick down (b): the arm should lower.



**DANGER!**

When the spindle carrier arm is lowered, there is always a potential for crushing anything in its movement range. Always work from the position given in the instructions keep well out of the working range of the various moving arms.



Move the joystick towards the left (c): the tool carriage and the mobile platform (13, Fig. D) should move towards the spindle (3, Fig. A); move the joystick towards the right (d) the carriage and platform should move away from the spindle.

2) Turn switch lever (9, Fig. C) towards the top: the spindle arms (3, Fig. A) should open; move the lever down and the spindle arms should close.

3) Push the lever (11, fig. C) upwards (e) to have the tool arm (14, fig. D) released and tilted outwards; push the lever downwards (f) to have the tool arm hooked in working position. Push the lever rightwards (h) to have the tool carriage moved rightwards; push it leftwards to have the tool carriage moved to the opposite side.



**DANGER!**

When the spindle arms open or closed, there is always a potential for crushing anything in their movement range. Always work from the position given in the instructions keep well out of the spindle's working range.



4) Depress the right pedal (10, Fig. C): the spindle (3, Fig. A) should turn clockwise; depress the left pedal: the spindle should turn anti-clockwise.

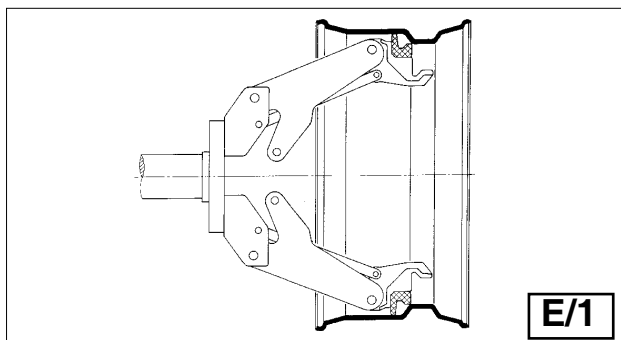
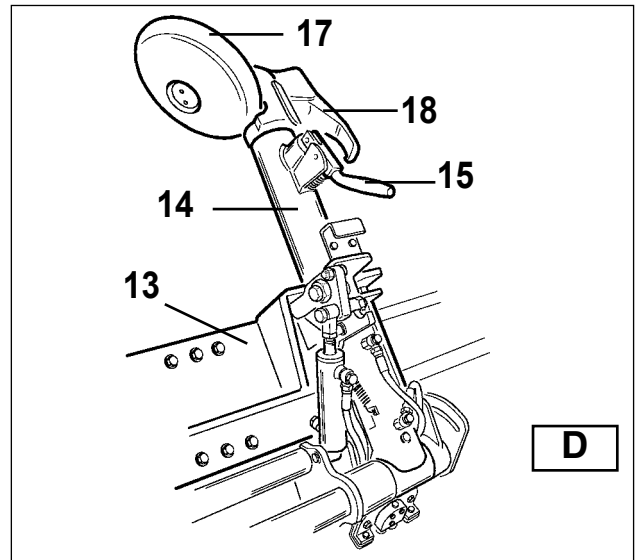
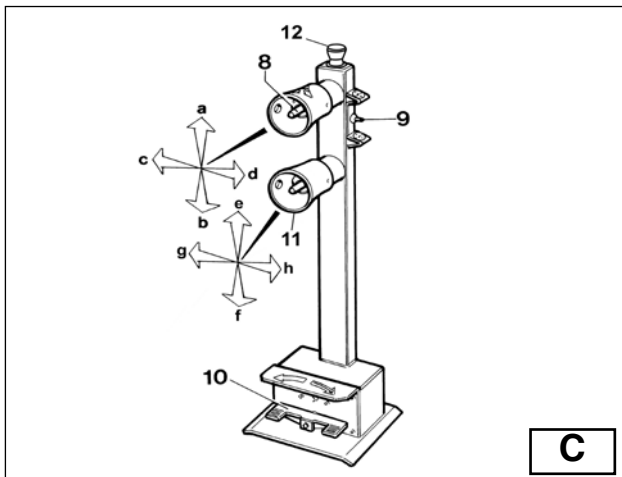

- 4) Check to be certain the hydraulic circuit is working correctly:  
 - move switch lever (9, Fig. C) towards the top until the spindle arms are fully extended.  
 - hold the switch lever in this position (top) and check if the pressure shown on the gauge on the swivel fitting is 130 bar  $\pm$  10%.  
**If the pressure shown is not as indicated here, DO NOT USE the tyre changer and call your nearest Assistance Centre.**

## 13 OPERATION

### 13.1 RIM CLAMPING



**WARNING!**

In rim clamping, make sure that jaws are properly positioned on the rim, so as to prevent the tire from falling over



1) Take the mobile control unit to work position B.

2) Pull the tool-holder arm (14, fig. D) into the upright position.

3) Operating from the mobile control unit, move the sliding carriage (item 13, fig. D) away from the self-centering chuck and place the tire assembly in vertical position over the sliding ramp.



**DANGER! POTENTIALLY HAZARDOUS OPERATION!**

Do it manually only if you are certain you can keep the tire assembly balanced. For large and heavy tyres an adequate lifting device must be used.

4) Continuing to operate from the mobile control unit, lift or lower the arm in order centre the self-centering chuck (3, fig. A) relative to the rim.

5) With the jaws (22, fig. A) in the closed position, move the tire assembly on the sliding ramp to the self-centering chuck. Operate the chuck switch (9, fig. C) to open the self-centering chuck and clamp the inner side of the rim.

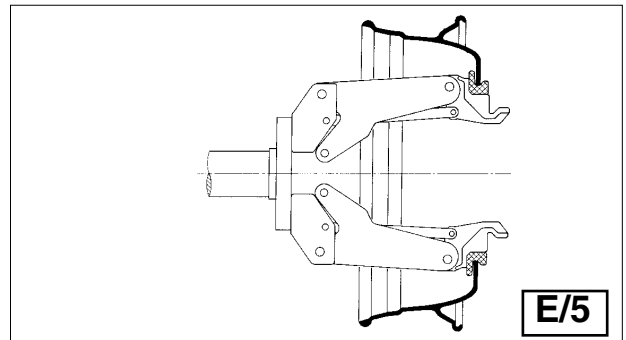
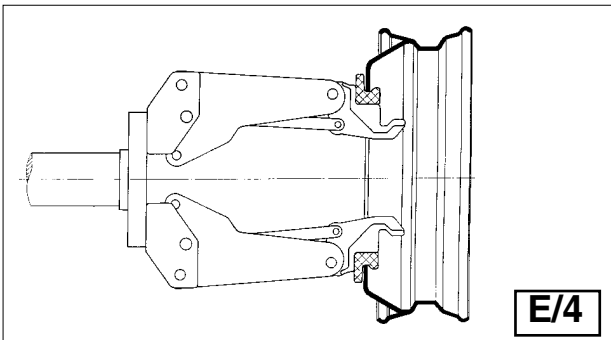
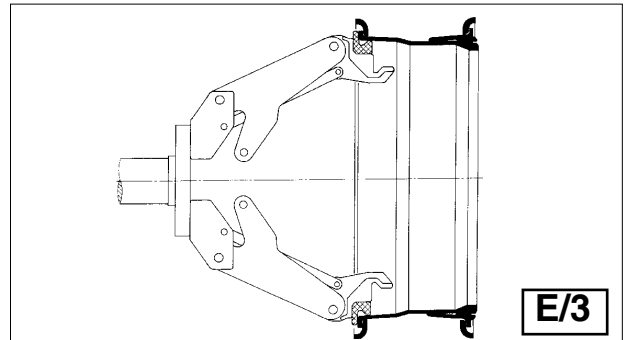
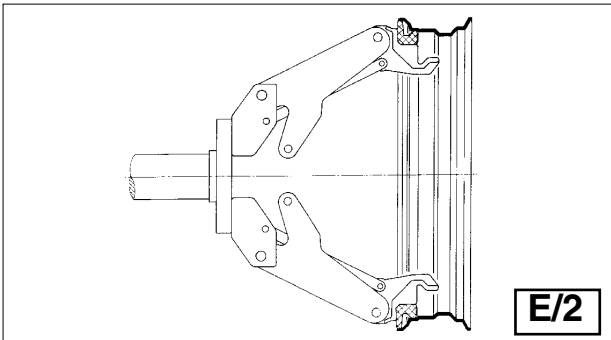

The most convenient locking position on the rim may be selected according to figs E/1 - E/2 - E/3 - E/4 - E/5 and E/6.  
**Always remember that the safest locking is on the central flange.**

N.B. for rims with channel, clamp the wheel so that the channel is near the outside of the rim (fig. E/1).

N.B. for rims exceeding a diameter of 46" and without a flange with central hole, the wheel can be locked with the 4 extensions 140/90.

### (# 9299272) LIGHT-ALLOY RIM CLAMPING

The **137/90** clamps - especially designed for operating on light alloy rims without damaging them - is available upon request.  
The **137/90** clamps are to be inserted (bayonet-like mounting) into the clamp support of the self-centering chuck (see fig. E/7).  
Thanks to a wing screw the clamp can be locked on the support.  
Lock the rim as illustrated in fig. E/8. The specially-made **138/90** alloy-rim pliers are also available.



#### **DANGER!**

**Do not vary the work area with a wheel clamped on the tyre changer and lifted up from the floor.**

## 13.2 TUBELESS AND SUPERSINGLE WHEELS

### BEAD LOSENING

1) Clamp the tire assembly on the self-centering chuck, as previously described, and ensure that the tyre is deflated.



2) Take the mobile control unit to work position C.

3) Lower the tool-holder arm (14, fig. F) into its working position and allow it to lock.



#### **DANGER!**

**Always check to be certain that the arm is correctly hooked to the carriage.**

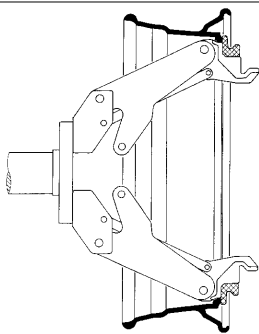

E/6

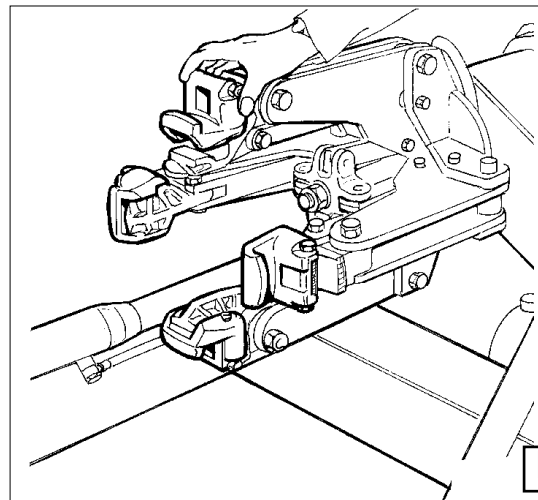

E/7

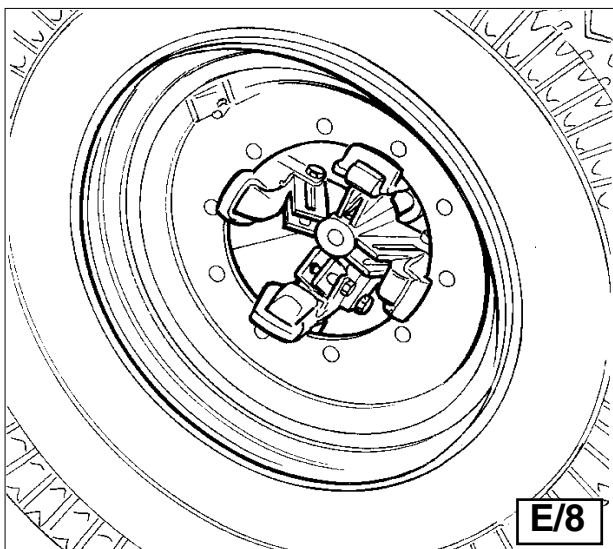

E/8

4) Operating from the mobile control centre, manoeuvre the wheel until the outside of the rim skims the bead-breaker disk (fig. F).



**DANGER!**

**The bead breaker disk must NOT be pressed against the rim but against the tire bead.**

5) Rotate the wheel and at the same time, advance the bead-breaker plate with small forward movements following the profile of the rim, with the plate.

6) Continue until the first bead is fully detached.

To facilitate this operation, lubricate the bead and the edge of the rim with tyre lubricant whilst the wheel is rotated.



**CAUTION!**

**To avoid all risk, lubricate the beads turning the tire assembly CLOCKWISE if you are working on the outside face and COUNTERCLOCKWISE if working on the inside face.**

Remember that the stronger the tyre's adherence to the rim, the slower must be the disk's penetration.

7) Bring the tool carrier arm (14, Fig. F) back from the edge of the rim. Release the hook, raise the arm to its non-working position, shift it and rehook it in its second work position (Fig. G).



**DANGER!**

**Do not hold your hands on the tool when you bring it back to its work position. Your hand(s) could be trapped between the tool and the tire assembly.**

8) Push the double headed tool lever (15, fig. G) and turn the head 180° until it locks automatically. Then slide the tool-holder arm along the sliding table and lock it in position.



9) Take the mobile control unit to work position D.

Repeat the operation previously described until the second bead is completely broken.

**N.B.:** During the bead breaking, the claw (18, fig. G) can be lowered so that it is out of the way.

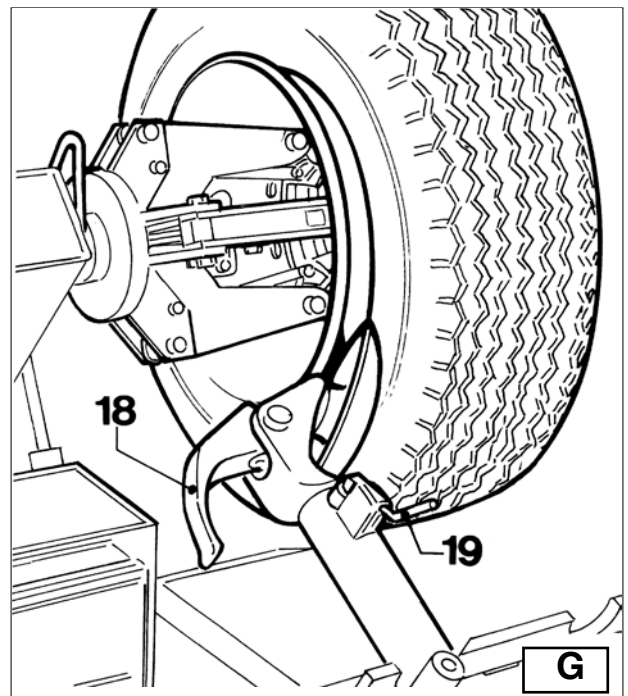
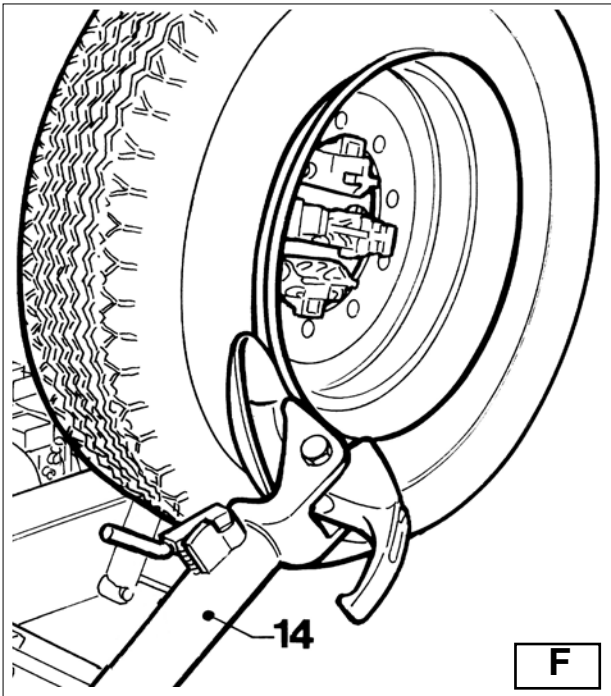

**DEMOUNTING**

**Tubeless tyres can be demounted in two ways:**

1) If the tyre is not difficult to demount, once the beads have been loosened, use the bead disk to push against the inside plane of the tire until both beads come off the rim (See Fig. H).

2) With Supersingle or very hard tires the procedure described above cannot be used. The hook tool will have to be used as follows:  
- Transfer the tool carrier arm to the outside plane of the tyre.



**Take the mobile control unit to work position C.**

- Rotate the wheel and at the same time move the hook tool forward inserting it between rim and bead until it is anchored to the bead (See Fig. I).
- Move the rim 1,5 - 2 inch (4-5 cm) from the tool taking care that it does not unhook from the bead.
- Move the hook tool towards the outside until the red reference dot is by the outside edge of the rim.



**Take the mobile control unit to position B.**

- Insert lever (17, Fig. I) between rim and bead at the right of the tool.
- Press down on the lever and lower the wheel to bring the edge of the rim about 2 inch (5 cm) from the hooked tool.
- Turn the wheel anticlockwise pressing down on lever until the bead is completely off.
- Move the tool carrier arm to its non-working position and then move it to the inside plane of the wheel.



**Take the mobile control unit to work position D.**

- Place the tool carrier arm in its working position, then use the bead disc to push against the inside face of the tire (see fig. H) it is best to do this with the wheel turning.
- Move the rim about 4-5 cm from the tool making sure the hook does not detach from the rim.

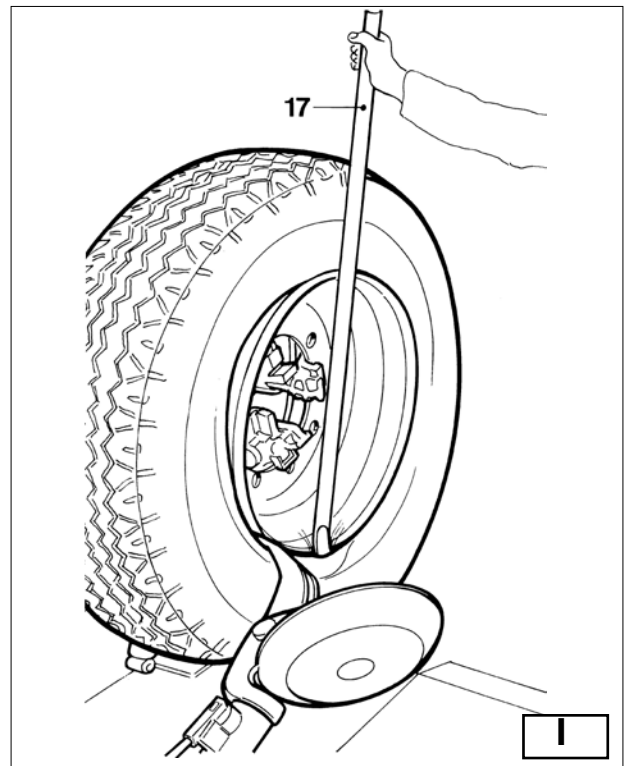
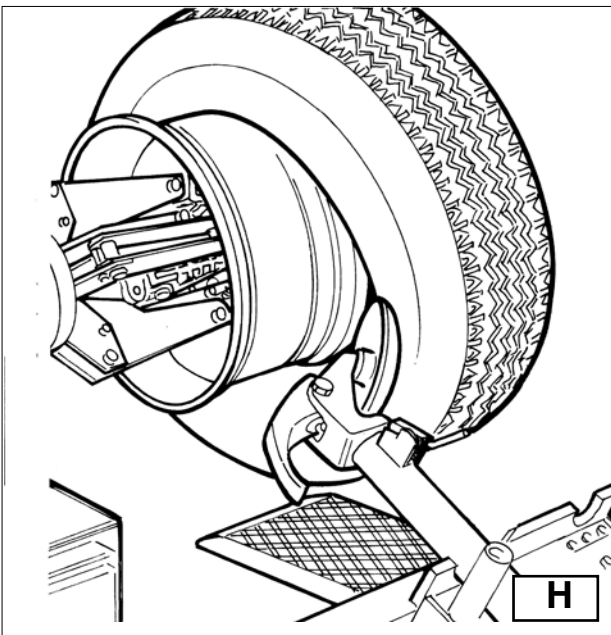

**Take the mobile control unit to work position B.**

- Always keep the rotating counterclockwise, while pushing with the bead disk
- Turn the wheel counterclockwise pushing with disk until the tire comes completely off the rim.



**DANGER!**

**When the beads come off the rim, the tire will fall. Check to make sure there are no by-standers in the work area.**

**MOUNTING**

Tubeless tires can be mounted using either the **bead breaker disk** or the **hook tool**.  
If the tire is not problematic, use the bead loosener disk.  
If the tire is very rigid, the hook tool must be used.

## TYRE MOUNTING WITH THE DISK

Follow these steps:

- 1) If the rim has been removed from the spindle, put it back on the spindle as described in the section on "CLAMPING THE WHEEL".
- 2) Lubricate both beads and the rim with tire manufacturer recommended lubricant.
- 3) Attach the g-clamp to the outside edge of the rim at the highest point (See Fig. M).



### CAUTION!

Make sure the g-clamp is firmly attached to the rim.



Take the mobile control unit to work position B.

- 4) Put the tire on the platform and lower the spindle (make sure the g-clamp is at the high point).
- 5) Lift the rim with the tire hook to it and turn it anticlockwise about 6-8 inches (15-20 cm.) The tire will be positioned tilted across the rim.

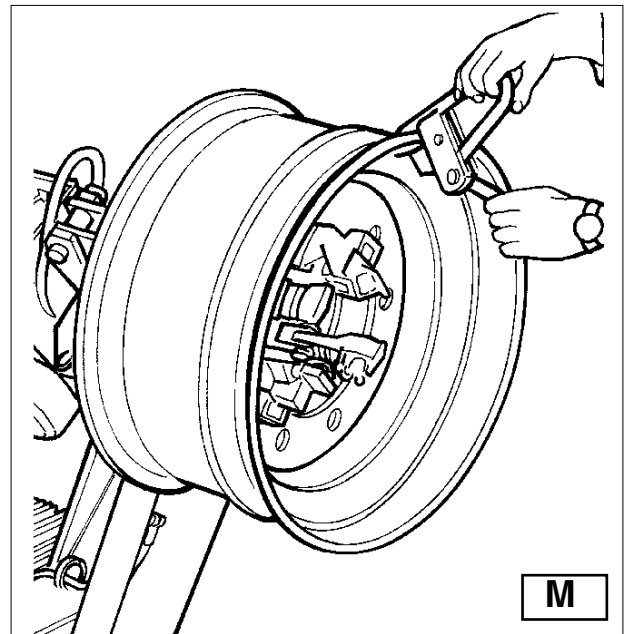
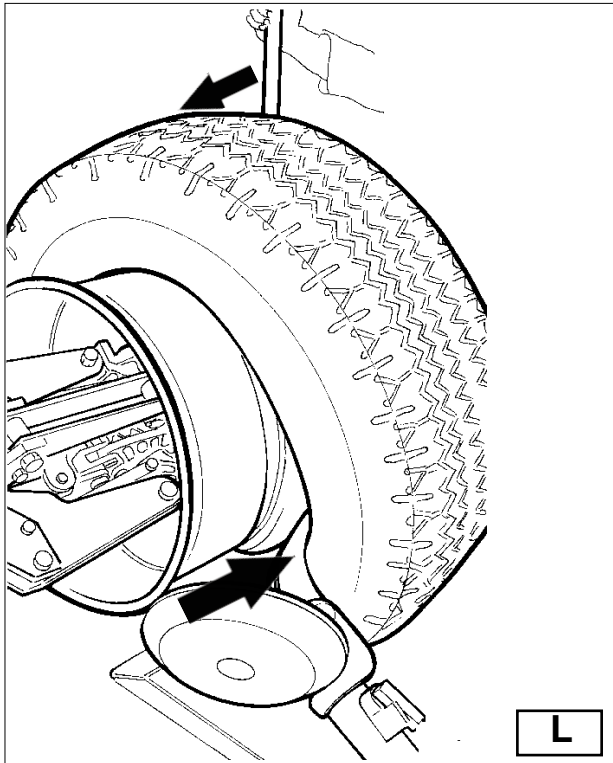

Take the mobile control unit to work position C.

- 6) Position the bead loosener disk against the second bead of the tire and turn the spindle until the clip is at the low point (at 6 o'clock).
- 7) Move the disk away from the wheel.
- 8) Remove the clip and replace it at 6 o'clock outside the second bead (See Fig. N).
- 9) Turn the spindle clockwise 90° to bring the clip to 9 o'clock.
- 10) Move the disk forward until it is about 0,5-1 inch (1-2 cm) inside the edge of the rim. Begin to turn the spindle clockwise checking to make sure that, with a 90° turn, the second bead begins to slip into the centre well.
- 11) When the bead is fully mounted, move the tool away from the wheel, tip it to its non-working position and remove the clip.
- 12) Position the platform under the wheel, lower the spindle until the wheel rests on the platform.



Take the mobile control unit to work position B.

- 13) Close the arms of the spindle completely. Support the wheel to prevent it falling off.



### DANGER!

Potentially hazardous operation!

Do it manually only if you are certain you can keep the tire assembly balanced. For large and heavy tires

- 14) Move the ramp to remove the tire assembly from the spindle.
- 15) Remove the tire assembly.

**NB: If the tire permits it, the operation described above can be speeded up by mounting both beads at the same time:**

- Follow the steps described under points 1,2,3,4 described above but instead of attaching the g-clamp to just the first bead (refer to point 4) clip it to both.
- Lift the rim with the tire hooked to it and turn it counterclockwise 6-8 inches (15-20 cm) (clip at 10 o'clock).
- Follow the steps described in points 10,11,12,13,14,15 above.

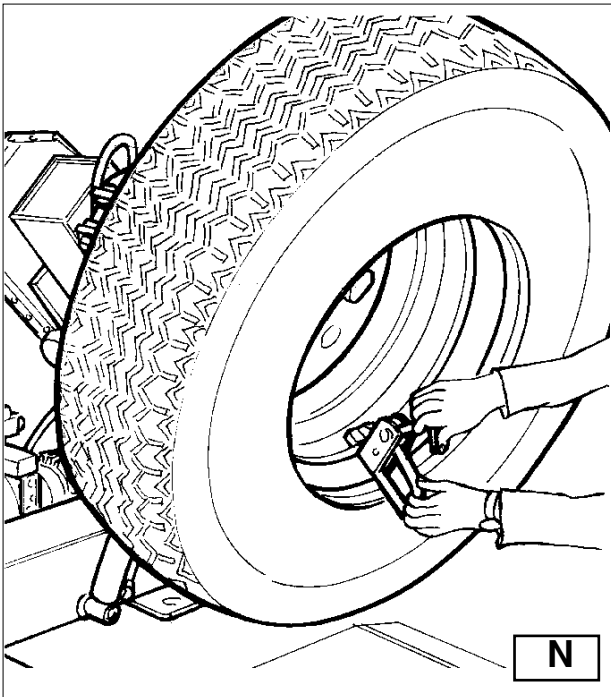

### **MOUNTING WITH THE HOOKED TOOL**

- 1) Follow the steps described in points 1,2,3,4,5 for mounting with the disk.
- 2) Move the tool carrier arm to its non-working position. Move it to the inside face of the tire and rehook it at this position.
- 3) Check to make sure the hook tool is positioned facing the tire bead. If not, press lever (15, Fig. D) and turn it 180°.



**Take the mobile control unit to work position D.**

- 4) Move the tool forward until the red reference dot is lined up with the outside edge of the rim and about (5 mm) from it (See Fig. O).



**Take the mobile control unit to work position C.**

- 5) Move to the outside of the tire assembly and check the exact position of the hook visually and adjust it as needed. Then turn the spindle **clockwise** until the g-clamp is at the bottom (6 o'clock). The first bead will be mounted on the rim.
- 6) Remove the g-clamp.



**Take the mobile control unit to work position D.**

- 7) Remove the tool from the tire.
- 8) Move the tool carrier arm to its non-working position. Move it to the outside face of the tire and rehook it in this position.
- 9) Turn the tool 180° with lever (15, Fig. D).
- 10) Attach the g-clamp at the bottom (6 o'clock) outside the second bead (See Fig. N).



**Take the mobile control unit to work position C.**

- 11) Turn the spindle **counterclockwise** to about 90° (clip at 9 o'clock).
- 12) Bring the tool forward until the red reference dot is lined up with the outside edge of the rim and about 1/4 inch (5 mm) from it. Begin to turn the spindle **counterclockwise** and check if, after about 90° of rotation the second bead has started to slip into the centre well. Continue turning until the g-clamp is at the bottom (6 o'clock). The second bead will now be mounted on the rim.
- 13) Follow the steps described in points 11, 12, 13, 14, 15 for mounting with the disk, since this will ensure that the tire assembly is removed correctly from the machine.



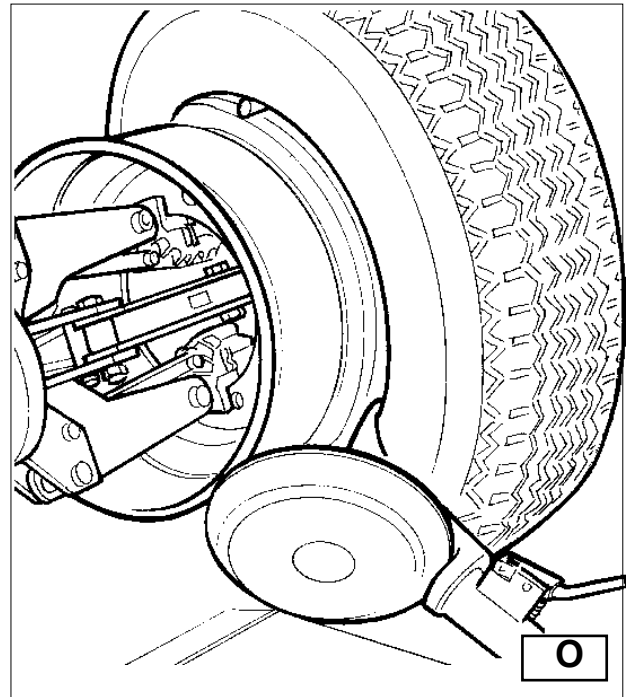
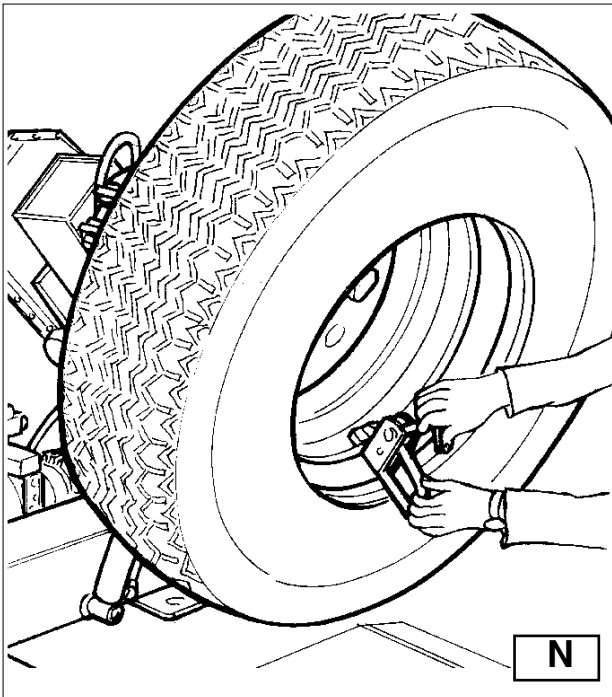

13.3

## TUBE TIRES

### BEAD LOOSENING

**WARNING:** release inflation tire so that the valve, coming inside the rim, is not an obstacle during bead loosening.

Follow all the steps described previously for bead loosening tubeless tires.

With tube tires, however, stop disk movement as soon as the bead has loosened to avoid damaging the tube inflation valve.

### DEMOUNTING



Take the mobile control unit to work position C.

- 1) Tip the tool carrier arm (14, Fig. D) to its non-working position. Move it to the outside plane of the wheel and rehook it in this position.
- 2) Rotate the wheel and at the same time move the hook tool (18, Fig. D) forward inserting it between rim and bead until it is anchored to the tool.
- 3) Move the rim 1,5 - 2 inches (4-5 cm) from the tool taking care that it does not unhook from the bead.
- 4) Move the hook tool towards the outside until the red reference dot is by the outside edge of the rim.



Take the mobile control unit to work position B.

- 5) Insert lever (see Fig. P) between rim and bead at the right of the tool.
- 6) Press down on the lever and lower the wheel to bring the edge of the rim about (5 mm) from the hooked tool.
- 7) Turn the wheel counterclockwise pressing down on lever until the bead is completely off.
- 8) Move the tool carrier arm to its non-working position. Lower the spindle until the tire is pressed down against the platform. As the platform is moved slightly towards the outside, the tire will open a little and thus create enough space to remove the inner tube.
- 9) Remove the inner tube and lift the wheel back up.

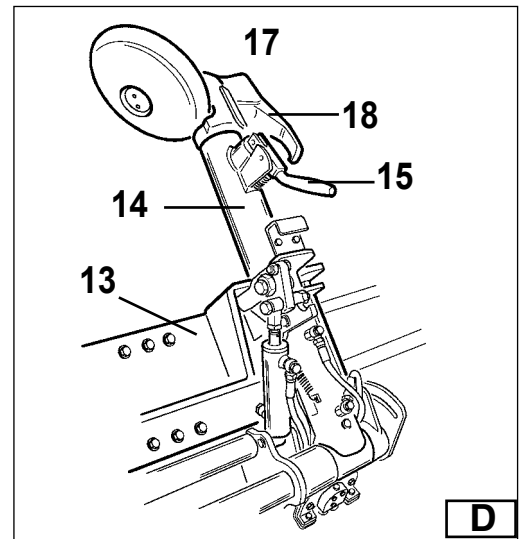
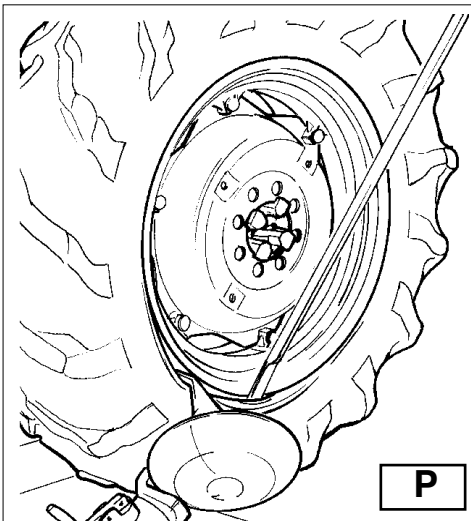



Take the mobile control unit to work position D.

10) Move the tool carrier arm to the inside face of the tire, turn the hook tool 180° and lower the arm to its work position. Insert it between rim and bead and move it until the bead is by the front edge of the rim (best to do this with the wheel turning).

11) Move the rim about 1,5 - 2 inches (4-5 cm) from the tool making sure the hook does not detach from the rim.



Take the mobile control unit to work position B.

12) Move the hook tool so that its red reference dot is about 1,2 inches (3 cm) inside the rim.

13) Insert lever between rim and bead at the right of the tool (See Fig. Q).

14) Press down on the lever and lower the tire to bring the edge of the rim about 2 inches (5 cm) from the hooked tool. Turn the tire counter clockwise pressing down on lever until the tire comes completely off the rim.



**DANGER!**

When the beads come off the rim, the wheel will fall. Check to make sure there are no by-standers in the work area.

**MOUNTING**

1) If the rim has been removed from the spindle, put it back on the spindle as described in the section on "RIM CLAMPING".

2) Lubricate both beads and the rim with tire manufacturer recommended lubricant.

3) Attach the g-clamp to the outside edge of the rim at the highest point (See Fig. R).



**CAUTION!**

Make sure the g-clamp is firmly attached to the rim.



Take the mobile control unit to work position B.

4) Put the tire on the platform and lower the spindle (make sure the g-clamp is at the high point) to hook the first bead on the g-clamp.

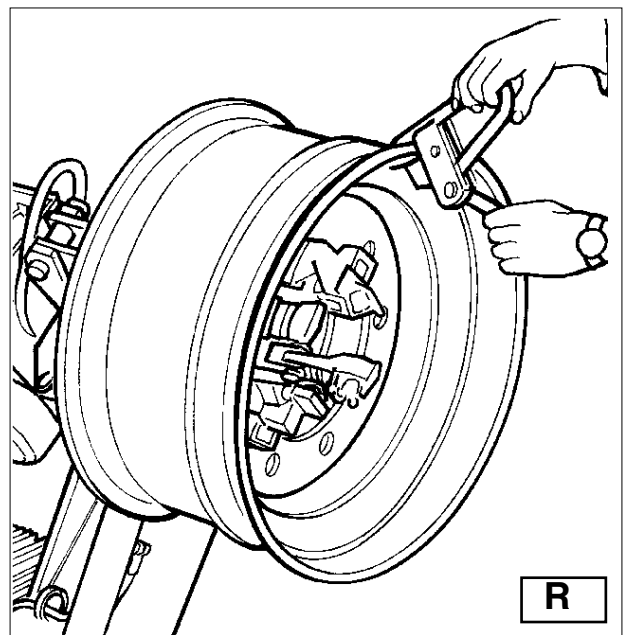
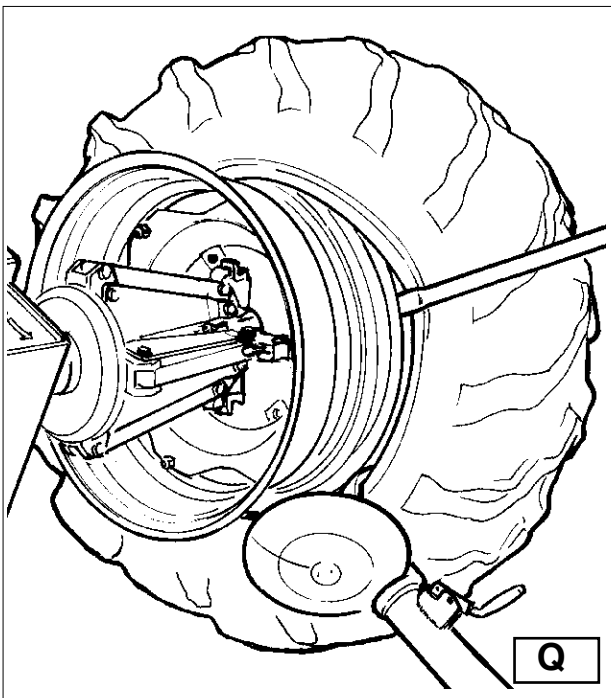

5) Lift the rim with the tire hooked to it and turn it counterclockwise about 6-8 inches (15-20 cm.) The tire will be positioned inclined across the rim.

6) Move the tool carrier arm to its non-working position. Move it to the inside face of the tire and rehook it in this position.

7) Check to make sure the hook tool is positioned facing the tire bead. If not, press the lever (15, Fig D) and turn it 180°.



Take the mobile control unit to work position D.

8) Move the tool forward until the red reference dot is lined up with the outside edge of the rim and about 2 inches (5 mm) from it (See Fig. S).



Take the mobile control unit to work position C.

9) Move to the outside of the tire and check the exact position of the hook visually and adjust it as needed. Then turn the spindle **clockwise** until the g-clamp is at the bottom (6 o'clock). The first bead will be on the rim. Remove the g-clamp.



**Take the mobile control unit to work position D.**

10) Remove the tool from the tire.

11) Move the tool carrier arm to its non-working position. Move it to the outside face of the tire.

12) Turn the tool 180° with lever (15, Fig. D).



**Take the mobile control unit to work position B.**

13) Turn the spindle until the valve hole is at the bottom (6 o'clock).

14) Move the ramp (4 Fig. A) under the tire and lower the spindle until the tire is pressed down against the ramp. As the ramp is moved slightly towards the outside, the tire will open a little and thus create enough space to insert the inner tube.

**NB: The valve hole may be asymmetrical to the centre of the rim. In this case position and insert the inner tube as shown in Fig. T.** Insert the valve through the hole and fix it with its locking ring.

15) Place the inner tube in the drop center of the rim (NB: to facilitate this, turn the spindle clockwise).

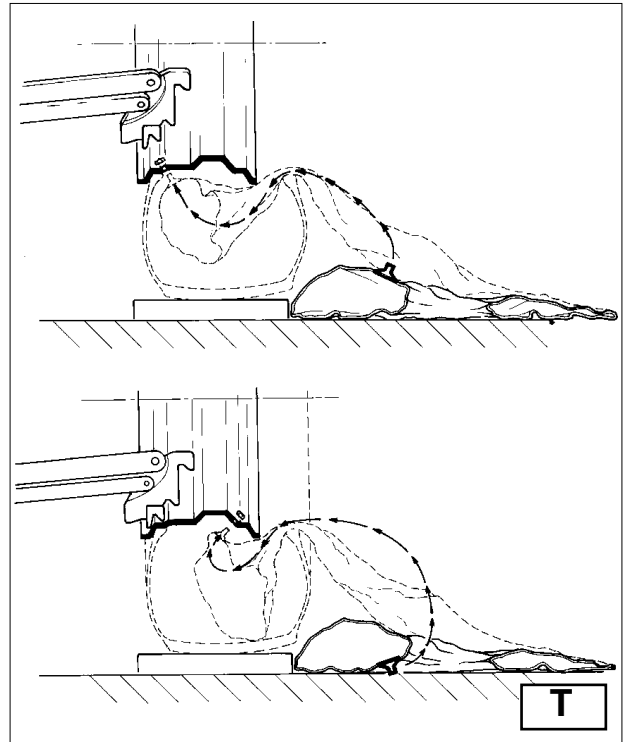
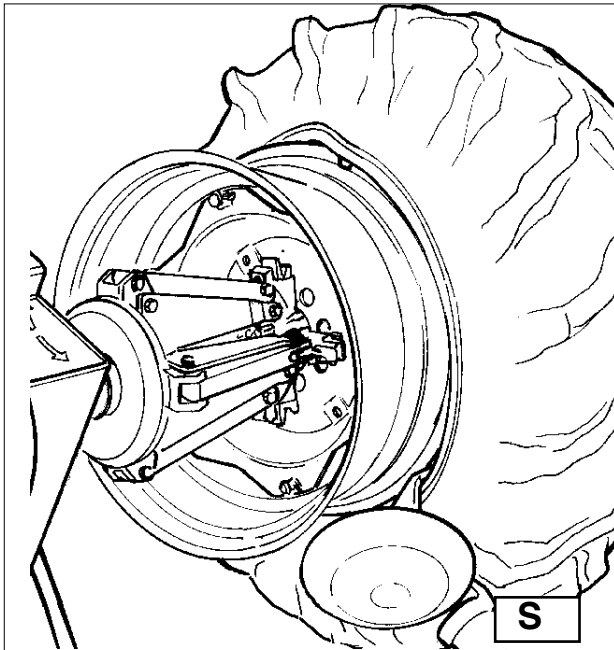

16) Turn the spindle until the valve is at the bottom (6 o'clock).

17) Inflate the inner tube a little (until it has no folds) so as not to pinch it while mounting the second bead.

18) Attach an extension to the valve and then remove the locking ring.

**NB: The purpose of this operation is to allow the valve to be loose so that it is not ripped out during second bead mounting.**



**Take the mobile control unit to work position C.**

19) Lift the tire again and attach the g-clamp outside the second bead about 8 inches (20 cm) to the right of the valve (See Fig. U).

20) Turn the spindle clockwise until the g-clamp is at 9 o'clock.

21) Move the tool carrier arm (14, Fig. D) to its working position.

22) Bring the tool forward until the red reference dot is lined up with the outside edge of the rim and about 1/4 inch (5 mm) from it.

23) Turn the spindle a little **clockwise** until you can insert the bead guide lever into its seating on the hook tool (See Fig. V). This lever can be supplied on demand.

24) Pull back on this lever which will guide the bead into drop center. Continue to turn the spindle until the tire is completely mounted on the rim.

25) Remove the g-clamp. Remove the hook tool by turning the spindle counterclockwise and moving it towards the outside.

26) Tip the tool carrier arm to its non-working position.

27) Position the ramp directly under the tire and lower the spindle until the wheel rests on the ramp.



**Take the mobile control unit to work position B.**

28) When the tire is resting on the ramp, check to make sure the valve is perfectly centered with its hole. If it is not, turn the spindle slightly to adjust the position. Fix the valve with its locking ring and remove the extension.

29) Close the arms of the spindle completely. Support the tire to prevent it falling off.



**DANGER! POTENTIALLY HAZARDOUS OPERATION!**

Do it manually only if you are certain you can keep the tire assembly balanced. For large and heavy tires an adequate lifting device must be used

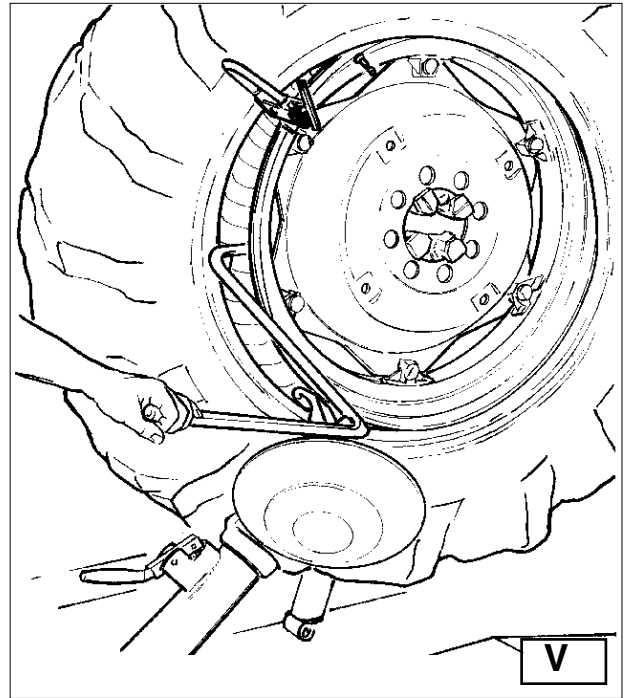
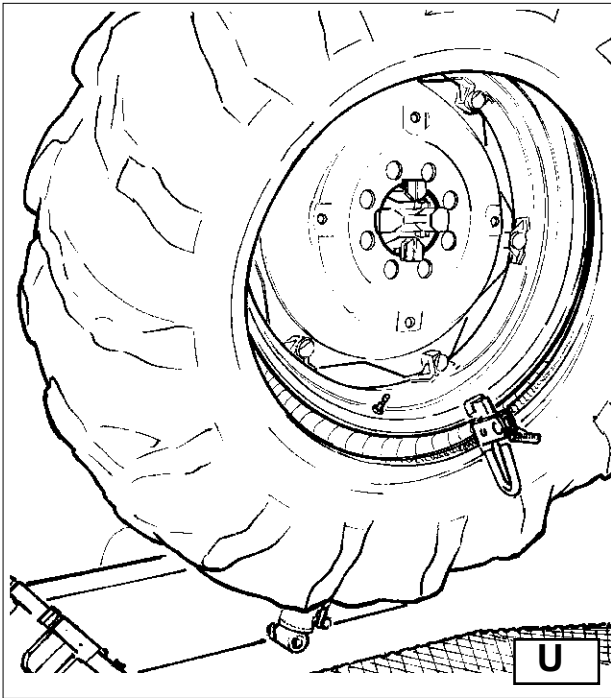

30) Move the platform to release the tire from the spindle.

31) Remove the tire.

13.4

## WHEELS WITH SPLIT RING

### BEAD BREAKING AND DEMOUNTING

#### TIRE ASSEMBLY WITH 3-PIECE RINGS

1) Clamp the tire on the spindle as described previously and check to make sure it has been deflated.



2) Take the mobile control unit to work position B.

3) Lower the tool carrier arm (14, Fig. D) to its work position and double check it is locked in position by its hook.

4) Position the bead loosener disk as levelled with the rim (See Fig. W).

5) Turn the spindle and at the same time move the disk forward a bit at a time following the contour of the rim until the first bead is completely free (NB: lubricate while doing this).

**CAUTION!** If the tire has an inner tube, work very carefully and be prepared to stop the disk immediately once the bead has been broken so as not to damage the valve and the inner tube.

6) Repeat this procedure but this time bring the disk against the split-ring (See Fig. Z) until the lock ring is freed. Remove this with the special lever (20, Fig. Z) or with the help of the disk.

7) Remove the split-ring.

8) Move the tool carrier arm (14, Fig. D) back from the edge of the rim. Release the hook and tip the arm to its non-working position. Move the tool carrier arm to the inside face of the tire.

9) Press lever (15, Fig. D) and turn the tool head 180° which will automatically lock in this position. Lower the arm to its working position.

10) Turn the spindle and at the same time bring the bead loosener disk up against the tire following the contour of the split-ring until the second bead has been loosened (NB: Lubricate during this process).

Continue to move the disk forward until about half the tire has demounted from the rim (See Fig. K).

11) Move the tool carrier arm to its non-working position.

12) Move the ramp (4, Fig. A) directly under the tire.

13) Lower the spindle until the tire is resting on the ramp.

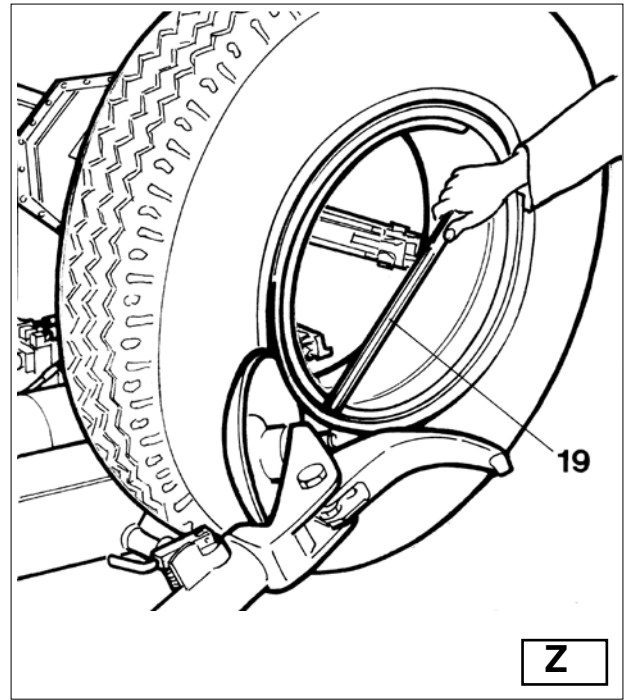
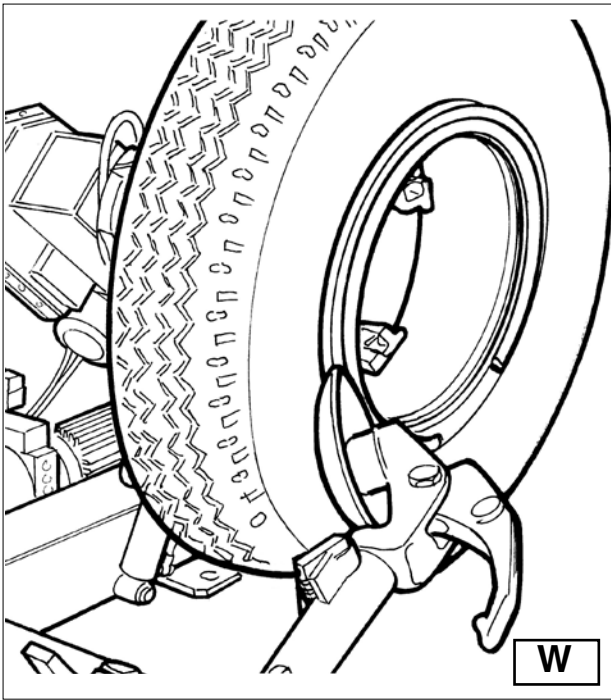

Take the mobile control unit to work position B.

14) Move the ramp towards the outside until the tire is completely off the rim. Watch out for the valve!

#### TIRE ASSEMBLY WITH 5-SEGMENT SPLIT RINGS

1) Clamp the tire on the spindle as described previously and make sure it is deflated.



Take the mobile control unit to work position C.

2) Lower the tool carrier arm (14, Fig. D) to its work position until its hook has engaged into position on the carriage.

3) Use the joystick to position the wheel so that the bead loosened disk touches up against outside edge of the centre well rim.

4) Turn the spindle and at the same time move the bead loosened disk forward until the split-ring is detached.

Watch out for the O-ring.

5) Repeat this operation but this time move the disk against the split-ring (See Fig. Z) until the locking ring is released. this ring can be removed with the special lever (20, Fig. Z) or with the help of the bead disk.

6) Remove the O-ring

7) Move the tool carrier arm (14, Fig. D) back from the edge of the rim. Release the hook and tip the arm to its non-working position. Move the tool carrier arm to the inside face of the tire.

8) Press lever (15, Fig. D) and turn the tool head 180° which will automatically lock in this position. Lower the arm to its working position.



Take the mobile control unit to work position D.

9) Turn the spindle and at the same time bring the bead loosener disk up against the tire between the rim and bead. Move the disk into the tire only when the bead has started to detach from the rim and move the bead to the outside edge of the rim. (NB: Lubricate during this process).

10) Tip the tool carrier arm to its non-work position.



Take the mobile control unit to work position B.

11) Move the ramp (4, Fig. A) directly under the tire.

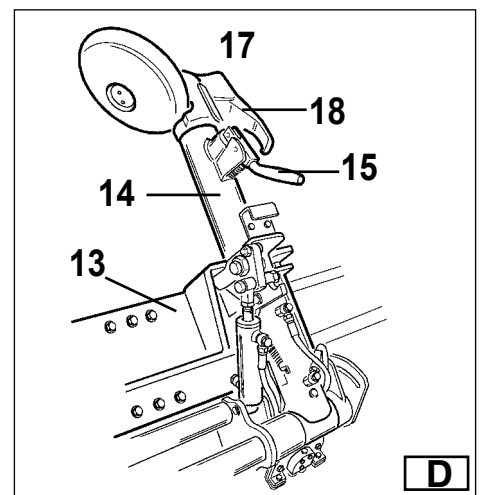
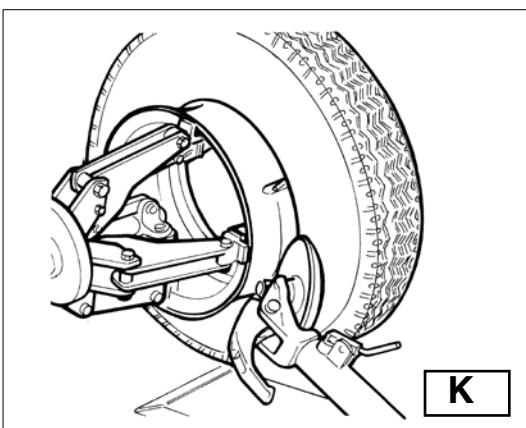

- 12) Lower the spindle until the tire is resting on the ramp.
- 13) Move the ramp towards the outside until the tire together with the split ring comes completely off the rim.
- 14) Remove the rim from the spindle.
- 15) Position the tire on the ramp with the split ring turned towards the spindle.
- 16) Clamp the split ring on the spindle as explained in the section of RIM CLAMPING.



**DANGER!**

The tire is not attached to the split ring completely. Any strain on it during positioning or clamping operations could cause it to detach and fall.



Take the mobile control unit to work position D.

- 17) Lift the tire assembly.
  - 18) Move the tool carrier arm back to its work position.
  - 19) Position the spindle so that the bead loosener disk is lined up with the bead.
  - 20) Turn the spindle and move the disk forward until the tire comes completely off the split ring.
- NB:** This double bead loosening procedure can be eliminated by using the **PAIR OF CLAMPS # 9299273** (optional) that fix the split-ring to the rim so that they are loosened out at the same time.



**DANGER!**

When the beads come off the rim, the wheel will fall. Check to make sure there are no by-standers in the work area.

**MOUNTING**

**TIRE ASSEMBLY WITH 3-PIECE SPLIT-RINGS**

- 1) Move the tool carrier arm to its non-working position. If the rim has been removed from the spindle, put it back on the spindle as described in the section on "RIM CLAMPING".  
If the tire is tubed, position the rim with the valve slot at the bottom (6 o'clock).
- 2) Lubricate both beads and the rim with tire manufacturer recommended lubricant.



Take the mobile control unit to work position B.

- 3) Move the ramp to be able to place the tire on it.
- NB:** If the tire is tubed, position the rim with the valve slot at the bottom (6 o'clock).
- 4) Lower or raise the spindle to centre the rim and the tire.
  - 5) Move the ramp forward until the rim is inserted into the tire.  
**CAUTION!** If the tire is tubed push the valve inside so as not to damage it.  
Move forward with the ramp until rim is completely in the tire.
  - 6) Bring the tool carrier arm to the outside face and lower it to its work position with the disk towards the tire.  
If the tire is not inserted sufficiently on the rim, move the spindle until the tire bead is by the disk. Bring the disk forward (with the spindle turning) until it is completely inserted.
  - 7) Put the split-ring on the rim and then install the locking ring with the help of the disk as shown in Fig. Y.
  - 8) Move the tool carrier arm to its non-working position and, at the same time, close the spindle arms. Support the wheel so that it does not fall off.



**DANGER!**

When the beads come off the rim, the tire will fall. Check to make sure there are no bystanders in the work area.

- 9) Move the ramp to free the tire from the spindle.
- 10) Remove the tire.

**TIRE ASSEMBLY 5-SEGMENT SPLIT-RINGS**

- 1) Move the tool carrier arm to its non-working position. If the rim has been removed from the spindle, put it back on the spindle as described in the section on "RIM CLAMPING".
- 2) Lubricate both beads and the rim with tire manufacturer recommended lubricant.

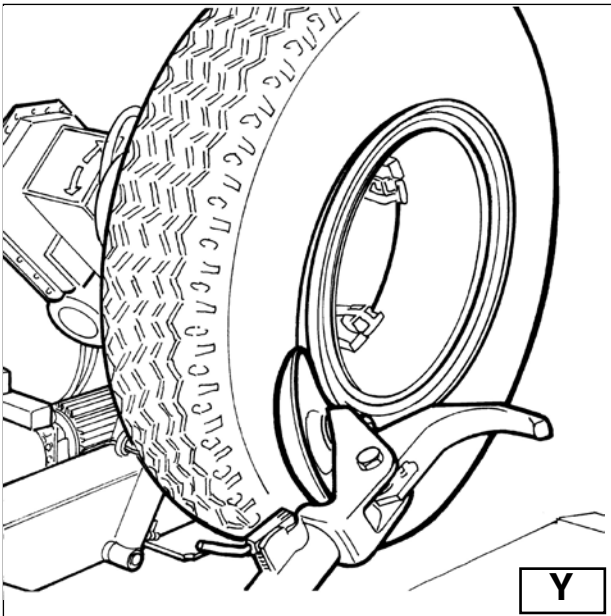

**Take the mobile control unit to work position B.**

- 3) Move the platform to be able to place the tire on it.
- 4) Lower or raise the spindle to centre the rim and the tire.
- 5) Move the ramp forward until the rim is inserted into the tire.  
Move forward with the ramp until rim is completely in the tire.
- 6) Put the split-ring on the rim (with the lock ring already mounted).  
If the rim and the split-ring have slits for fixing devices, make sure they are lined up with each other.



**Take the mobile control unit to work position C.**

- 7) Move the tool carrier arm to the outside in its work position with the bead loosener disk facing the tire.  
If the split-ring is not inserted sufficiently on the rim, move the spindle until the split-ring is by the disk. Bring the disk forward (with the spindle turning) until you "observe" the O-ring seating.
- 8) Lubricate the O-ring and its seating.



**Take the mobile control unit to work position B.**

- 9) Position the locking ring on the rim with the help of the disk as shown in Fig. Y.  
Move the tool carrier arm to its non-working position and close the spindle arms completely. Support the tire so that it does not fall off the spindle.



**DANGER! POTENTIALLY HAZARDOUS OPERATION!**

**Do it manually only if you are certain you can keep the wheel balanced. For large and heavy tires an adequate lifting device must be used.**

- 10) Move the ramp to free the tire from the spindle.
- 11) Remove the tire.



**DANGER!!**

**Do not inflate the tire with the tire assembly on the spindle. Tire inflation is potentially hazardous and should only be done by removing the tire assembly from the spindle and placing it inside a safety cage.**

## 14 ORDINARY MAINTENANCE



### WARNING!

Each maintenance operation must be performed only after the disconnection of the plug from electric network.

To ensure that this tire changer works perfectly over the years, carry out the routine maintenance schedule described below:

**1) Lubricate** the following parts from time to time, after a thorough cleaning with naphtha:

- the various swivels on the spindle
- the tool bracket slide runner
- the carriage guide plate.

**2) Grease** the spindle bracket swivel from time to time. Add the grease through the grease fitting (See Fig. J) using ordinary lubricating grease.

**3) Frequently check** the oil level in the hydraulic power pack. Use the dipstick under the reservoir cap.

If necessary top up with Esso Nuto H46 or similar hydraulic oil (eg, Agip Oso 46, Shell Tellus Oil 46, Mobil DTE 25, Castrol Hyspin AWS 46, Chevron RPM EP Hydraulic Oil 46, BP Energol HLP).

**4) Frequently check** the oil level in the gear unit which, when the tool carrier bracket is completely lowered down, should not show the sight glass on the gear casing as completely empty. If necessary top up with Esso Spartan EP 320 or similar oil (eg, Agip F1 REP 237, BP GRX P 320, Chevron Gear Compound 320, Mobil Gear 632, Shell Omala Oil 320, Castrol Alpha SP 320).

If the oil in the gear unit or the hydraulic power pack has to be changed, note that the gear unit casing and the power pack reservoir have specific drain plugs.

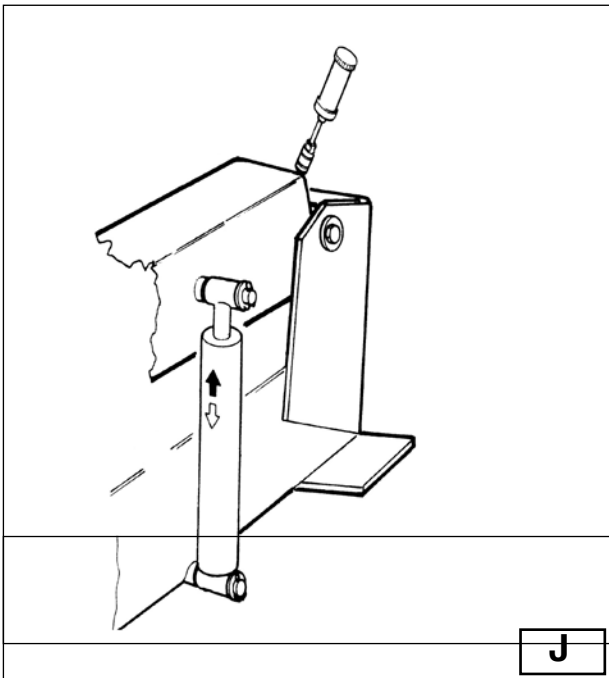

### WARNING!

Dispose of the used oil in approved waste oil container.

## 15 TROUBLE SHOOTING

### PROBLEM

After having switched the general button on the electric pack, the general warning light does not light on and no control can function.

### CAUSES

- 1) The power plug is not inserted.
- 2) No power from the mains electric supply.

### REMEDIES

- 1) Insert the plug correctly in its socket.
- 2) Reset the mains electric supply.



**PROBLEM**

After having switched the general button on the general warning light also switches on but the motor on the hydraulic power pack does not function.

**CAUSES**

1) The magneto-thermic switch for motor protection has been engaged, witting off the circuit.

**REMEDIES**

1) Call for technical aid to see what is the problem and restore the machine.



**WARNING:** If, despite the above mentioned indications the tire changer does not work properly, do not use it and call for technical service and support.

## 16 MOVING THE MACHINE

The tire changer has got a fork (1, Fig. A) which has been positionned there on purpose for moving the machine. Follow these instructions:

- 1) Low the clamping chuck arm (2, Fig. A) completely down.
- 2) Close completely the jaws of the chuck (3, Fig. A).
- 3) Bring the sliding carriage (4, Fig. A) at the end of its travel, near the arm.
- 4) Insert into the lifting fork a hoisting belt at least 2,5 inches (60 mm) wide and of a lenght sufficient to bring the hook of the belt above the tyre changer).
- 5) With the special belt ring bring the 2 ends of the belt together and lift with a sufficiently strong lifting truck.

## 17 STORING

If the machine as to be stored for a long time (3-4 months you have to:

- 1) Close the jaws of the chuck; low the chuckholding armdown; lowen the tool holding arm down, into the working position.
- 2) Disconnect the machine from all power sources.
- 3) Grease all the parts that could be damaged if they dry out:
  - the chuck
  - the slot of the tool holding arm
  - the slides of the carriage
  - the tool

Empty oil/hidraulic fluid reservoirs and wrap the machine in a sheet of protective platic to prevent dust from reaching the internal working parts.

If the machine as to start working again after a long storing period, it is necessary to:

- put the oil into the reservoirs again.
- restore the electric connection.

## 18 SCRAPPING A MACHINE

When your machine' s working life is over and it can no longer be used, it must be made inoperative by removing any connection to power sources.

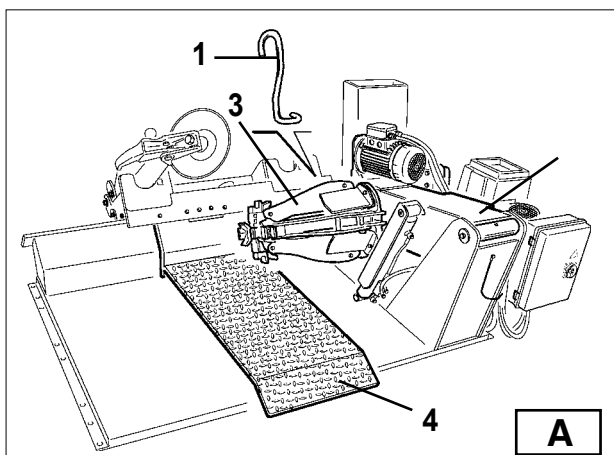

These units are considered as special waste material, and should be broken down into uniform parts and disposed of in compliance with current laws and regulations.

If the packing are not polluting or non-biodegradable, deliver them to appropriate handling station.



**WARNING!**

**If this machine catches fire, use dust or CO<sup>2</sup> extinguishers only.**

## 19 DATA ON SERIAL PLATE





The manufacturer's Serial plate is fixed on the back of the machine. It gives the following information:

- 1- Manufacturer information
- 2- Model
- 3- Serial number
- 4- Phases
- 5- Voltage requirements
- 6- Frequency
- 7- Rated draw
- 8- Year
- 9- Weight
- 10 - Absorbed power

FAC -SIMILE	[1]
Type:	[2] Nr. [3]
Volt: [5]	Amp: [7] Kw: [10]
Ph: [4]	Hz: [6] Year: [8]
Net Weight: 770 Kg. [9]	

## 20 ACCESSORIES

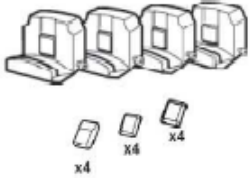
The following optional accessories are available for the tire changer:

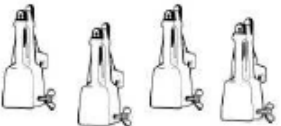
Item	Ref. Code #	Description
	9299274	Tubeless roller (not available for CHD4730 and 6330), alloy made
	9299269	Bead lifting guide bar for agricultural tires (not available for CHD4730 and 6330)
	9299273	Pair of g-clamps for bead loosening on tube tires/wheels with rim and additional ring
	9299272	Set of 4 clamp protectors for alloy wheels (not available for CHD4730)
	9299271	G-clamp for alloy wheels (wheel contact portion protected by nylon)
	9299270	Set of 4 clamping extensions 47"-56" (not available for CHD4730 and 6330)



**COATS**®

**HENNESSY Industries, INC**  
**1601 J.P. Hennessy Drive, LaVergne, TN 37086-3565 USA**  
**Toll Free 800-688-6496**  
**[www.ammcoats.com](http://www.ammcoats.com)**