

APX Tire Changer Series ***Unloading Procedures***

This is a supplement to your operating manual and covers unloading procedures for the COATS® APX Series Tire Changers. If you do not have your original operating manual, please call **COATS at 1-800-688-6359** to request an additional copy.

User Instructions

READ these instructions before placing unit in service KEEP these and other materials delivered with the unit in a binder near the machine for ease of reference by supervisors and operators.

HENNESSY INDUSTRIES, INC.

1601 J. P. Hennessy Drive, LaVergne, TN USA 37086 615/641-7533 800/688-6359

HENNESSY INDUSTRIES INC. Manufacturer of AMMCO®, COATS® and BADA® Automotive Service Equipment and Tools.

Manual Part No.: 85000267 03

Revision: 02/13

CAUTION

Watch for this symbol:



It Means: Hazards or unsafe practices, which may result in minor personal injury or product or property damage.

Unload Instructions

Review the following unload procedures carefully. Refer to them as necessary when the machine is delivered and unloaded to verify that you are proceeding properly and safely.



This unit weighs over 1,200 lbs. Do not attempt to lift or move without assistance. Make sure all moving parts are secured before moving the unit.



Proper unit installation is necessary for safe use and efficient operation. Proper installation also helps protect the unit from damage and makes service easier. Always place safety poster and instructions near the unit.

Machine Delivery Unload Procedure



A. It is acceptable to use a fork-truck to unload the machine that is on a pallet from a delivery truck.



B. It is acceptable to use a utility tilt trailer to unload the machine that is on a pallet from a delivery truck.



C. It is not acceptable and can be dangerous to use a lift-gate delivery truck to unload the machine from a delivery truck.

APX80 Unload Instruction

1. Remove lag bolts holding chassis to pallet.
2. Jack up rear of machine; install axle and wheels as shown.
3. Remove ramp planks and position as shown.
4. Jack up front of machine and install axle and wheels as shown.
5. Slowly push machine forward to position offload bracket over jack.
6. Jack up front of machine and slowly move machine off pallet.
7. Locate machine in shop at proper location and remove wheels and temporary off-load bracket.

APX80

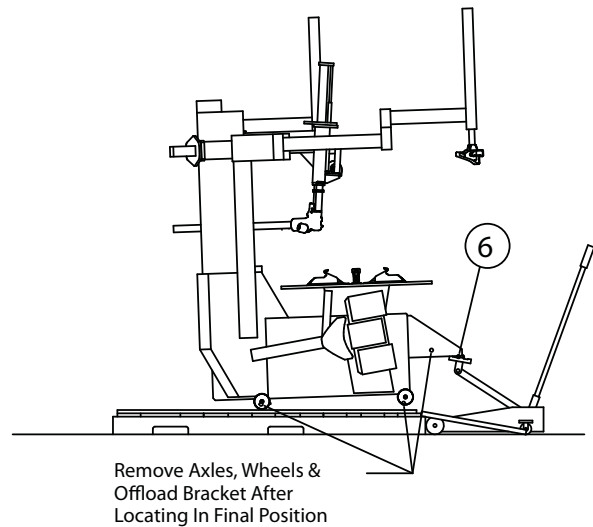
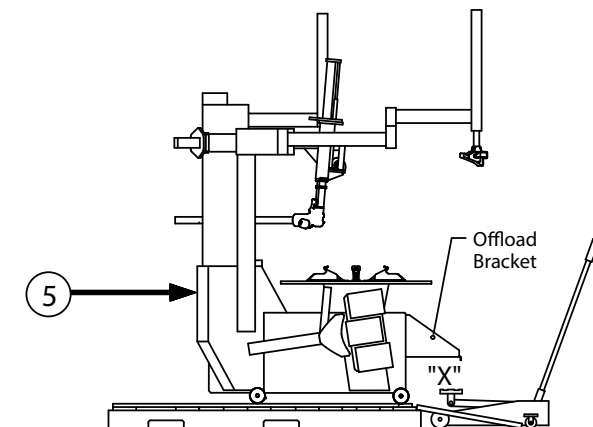
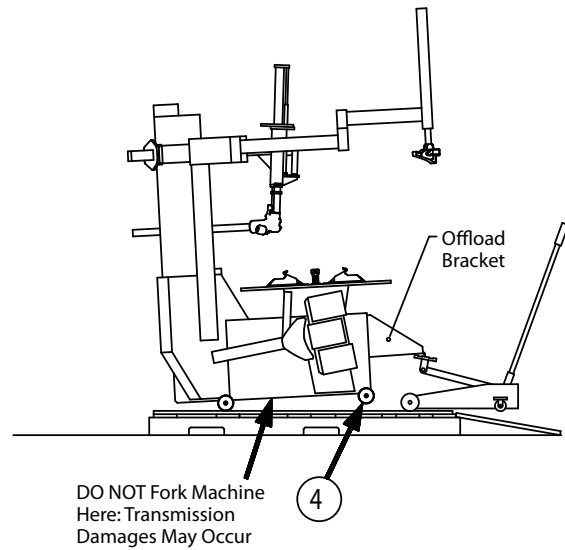
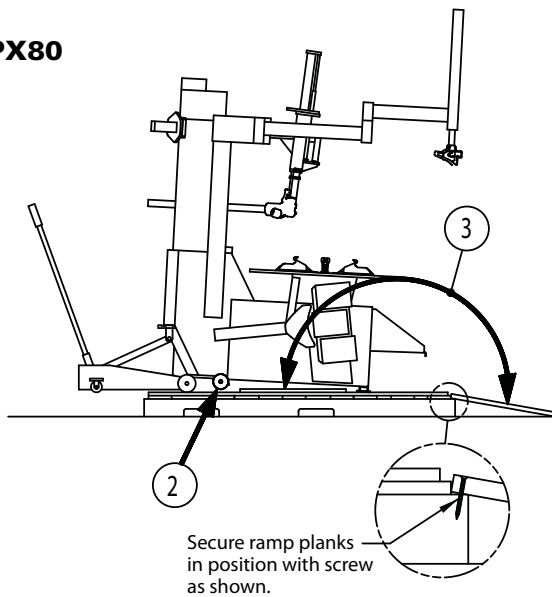

APX90 Unload Instruction

1. Remove lag bolts holding chassis to pallet.
2. Jack up rear of machine; install axle and wheels as shown.
3. Remove ramp planks and position as shown.
4. Move jack to front (add air pressure to machine).
5. Slowly push machine off pallet.
6. Locate machine in shop at proper location and remove wheels.

APX90

