

# **COATS®**

## **COATS 4300**

**ELECTRIC-HYDRAULIC TIRE CHANGER  
FOR TUBELESS TRUCK WHEELS**

INSTALLATION AND OPERATION INSTRUCTIONS  
MAINTENANCE INSTRUCTIONS

### **LIMITED WARRANTY**

COATS Industries, Inc. ("Seller") provides a one year limited warranty on parts and labor on all goods manufactured by it, including this product. The sole and exclusive warranty which Seller makes with respect to this product and all parts and accessories thereto which are sold by Seller is a warranty limited to defects in material or workmanship for a period of one year from the date of original purchase by Buyer from Seller. For purposes of the commencement of the one-year warranty period, the term "Buyer" shall not include wholesalers, retailers or others who buy this product for resale to end user. However, in no event shall the warranty extend beyond two years from the original sale (invoice data) of this product by Seller to anyone.

This warranty applies only to this product and any parts or accessories which are attached to or shipped by the Seller to Buyer with it. This warranty does not apply to equipment parts or accessories damaged by improper and/or negligent operation or maintenance, modification, misuse, abuse, neglect, abrasion or corrosion, nor to any equipment, parts, or accessories which were not manufactured by Seller. This warranty does not apply to any "wear out" components of this product.

"Wear out" shall mean those components or parts which are consumed, used or experienced wear during the ordinary operation of this product. This warranty shall be void if the equipment, parts, or accessories are dismantled, tampered with or repairs are attempted or made by anyone other than Seller or its authorized agent.

**THE EXPRESS WARRANTY SET FORTH HEREIN IS IN LIEU OF ALL OTHER WARRANTIES, EXPRESS OR IMPLIED, INCLUDING, BUT NOT LIMITED TO, ANY WARRANTIES OF MERCHANTABILITY OR FITNESS FOR A PARTICULAR PURPOSE, AND ALL SUCH WARRANTIES ARE HEREBY DISCLAIMED AND EXCLUDED BY SELLER. THERE ARE NO WARRANTIES WHICH EXTEND BEYOND THE DESCRIPTION ON THE FACE HEREOF.**

No equipment or parts or accessories shall be shipped by Buyer to Seller without first notifying Seller and specifying the nature of the claimed defect. Any such equipment, parts, or accessories claimed to be defective must be returned, freight prepaid, to COATS Industries, Inc., 11126 Air Park Road, Ashland, Virginia 23005. If inspection by Seller shows the equipment, part, or accessory to be defective, Seller will repair or replace the same and if the Seller elects to repair or replace the same, Seller will return the same to Buyer, freight prepaid.

Buyer's sole and exclusive remedy against Seller under this Limited Warranty shall be limited to repair or replacement, at Seller's option, of defective equipment, parts, or accessories covered here under. Seller's liability shall in no event exceed that expressly set forth herein, irrespective of the basis for any other claim, including but not limited to claim for breach of contract, breach of warranty, negligence, strict liability or tort, and under no circumstance shall be liable for incidental or consequential damages.

Seller shall not be liable for any losses, damages, or expenses, whether direct or indirect, incidental or consequential, caused by or resulting from the use of defective or non conforming equipment, parts, or accessories, or from delays in delivery. Buyer and Seller agree that the venue for any claim or breach or warranty shall be exclusively in the Circuit or General District courts of Hanover County, Virginia.

**TABLE OF CONTENTS**

1.0 INTRODUCTION	Page 4
1.1 USE LIMITATIONS	Page 4
1.2 NOTICE	Page 4
1.3 GENERAL SAFETY INSTRUCTIONS	Page 4
1.4 NOMENCLATURE	Page 4
1.5 SPECIFICATIONS	Page 5
1.6 DIMENSIONS OF THE MACHINE	Page 5
1.7 STANDARD ACCESSORIES	Page 5
1.8 ACCESSORIES ON REQUEST	Page 6
1.9 SAFETY PRECAUTIONS	Page 7
1.10 SAFETY DEVICES	Page 7
2.0 CARRIAGE INSTRUCTIONS	Page 8
2.1 UNCRATING INSTRUCTIONS	Page 8
2.2 INSTALLATION AREA	Page 8
3.0 INSTALLATION INSTRUCTIONS	Page 9
3.1 ELECTRIC INSTALLATION	Page 10
4.0 CONTROLS	Page 11
5.0 MOUNTING AND DEMOUNTING - GENERAL PRECAUTIONS	Page 12
5.1 LOCKING RIMS WITH A CENTER HOLE OF 220 AND 280MM	Page 12
5.2 LOCKING RIMS WITH A CENTER HOLE OF 164MM	Page 14
5.3 LOCKING RIMS WITH A CENTER HOLE OF 135 ~ 167MM	Page 14
5.4 DEMOUNTING TUBELESS TRUCK TIRES	Page 15
5.5 MOUNTING TUBELESS TRUCK TIRES	Page 16
6.0 MAINTENANCE	Page 18
7.0 MOVING THE MACHINE	Page 19
8.0 PUTTING THE MACHINE OUT OF SERVICE	Page 19
9.0 SCRAPPING THE MACHINE	Page 19
10.0 TROUBLE SHOOTING	Page 20

## 1.0 INTRODUCTION

Congratulations on purchasing the COATS 4300 electric - hydraulic tire changer.

This tire changer is designed for ease of operation, safe handling of rims, reliability and speed.

With a minimum of maintenance and care your tire changer will provide many years of trouble-free operation.

Instructions on use, maintenance and operational requirements of the machine are covered in this manual.



**STORE THIS MANUAL IN A SAFE PLACE FOR FUTURE REFERENCE. READ THIS MANUAL THOROUGHLY BEFORE USING THE MACHINE.**

### 1.1 USE LIMITATIONS

*The tire changer model COATS 4300 is intended to be used as a device to demount and mount tubeless truck tires with the following specifications:*

**Maximum tire diameter : 47" (1200 mm)**  
**Maximum tire width : 20" (500 mm)**  
**Maximum wheel weight : 440 lbs (200kg)**

*This device shall be used in the application for which it is specifically designed.*

*Any other use shall be considered as improper thus not reasonable.*

*In particular this device is not suitable to inflate tires. Inflation of tires shall be carried out in an approved inflation safety cage.*

*The manufacturer shall not be considered liable for possible damages caused by improper, wrong or non reasonable use.*

### 1.2 NOTICE

This manual is a part of the product. Read carefully the warnings and instructions of this manual since they provide important information concerning safety and maintenance.

### 1.3 GENERAL SAFETY INSTRUCTIONS

**THE USE OF THIS DEVICE IS ALLOWED ONLY TO PERSONNEL DULY TRAINED BY AN AUTHORIZED COATS DEALER.**

**ANY MISUSE OR MODIFICATION OF THIS DEVICE OR OF ITS PARTS OR COMPONENTS NOT PREVIOUSLY AUTHORIZED BY THE MANUFACTURER WAIVE THE MANUFACTURER FROM ANY DAMAGE CONSEQUENT OR RELATED TO THE ABOVE MENTIONED MISUSES.**

**REMOVING OR BYPASSING SAFETY DEVICES OR WARNING LABELS OF THE MACHINE IS A VIOLATION OF THE SAFETY REGULATIONS.**

**THE USE OF THIS DEVICE IS ALLOWED ONLY IN LOCATIONS WITH NO EXPLOSION OR FIRE HAZARD.**

**THIS EQUIPMENT IS DESIGNED TO RECEIVE ORIGINAL SPARE PARTS AND ACCESSORIES ONLY.**

**THE INSTALLATION SHALL BE CARRIED OUT ONLY BY QUALIFIED PERSONNEL AND WITHIN THE SCOPE OF THE INSTRUCTIONS PROVIDED IN THIS MANUAL.**

**CHECK FOR POSSIBLE DANGEROUS CONDITIONS DURING THE OPERATION OF THE MACHINE. IN SUCH A CASE STOP THE MACHINE IMMEDIATELY. IN CASE A DEFECTIVE FUNCTIONING CONDITION IS DETECTED, STOP USING THE MACHINE AND CALL THE AUTHORIZED COATS DISTRIBUTOR FOR ASSISTANCE.**



**ALL ELECTRICAL CONNECTIONS SHALL BE PERFORMED BY A LICENCED TECHNICIAN. ALL SERVICE MUST BE PERFORMED BY AN AUTHORIZED SERVICE TECHNICIAN.**

### 1.4 NOMENCLATURE

Before installing and using the tire changer it is suggested that you become familiar with the nomenclature of the machine's components (Fig.1).

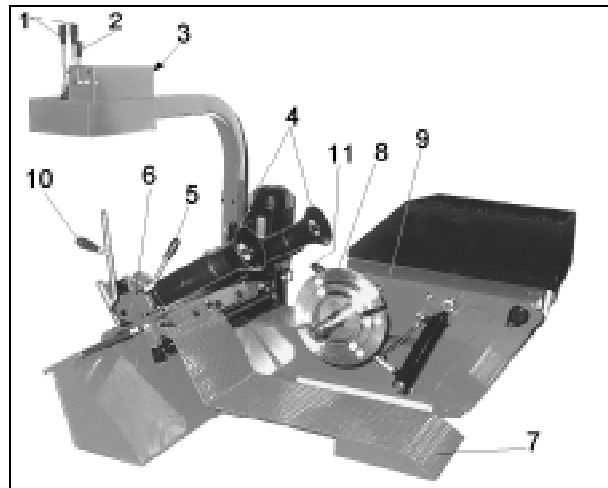

Fig. 1

287

1. Hydraulic controls
2. Chuck rotation switch
3. Main switch
4. Mount/demount rollers
5. Toolholder arm lock lever
6. Toolholder carriage
7. Footboard
8. Chuck
9. Chuck arm
10. Accessories peg
11. Chuck shaft lock/release lever

**1.5 SPECIFICATIONS**

Electric-hydraulic tire changer for tubeless truck wheels.

Weight with standard accessories	726 lbs (330 kg)
Electric specifications	220VAC, 1ph, 60Hz, 30A
Hydraulic motor power	0.75 kW (1 HP)
Chuck rotation motor power	0.75 kW (1 HP)
Rim diameter range	16" - 22.5"
Max. rim width	12"
Max. tire diameter	47" (1200 mm)
Max. tire width	20" (500 mm)
Max. chuck torque	1323 ft·lbs (1800 Nm)
Chuck rotation speed (50 Hz)	4 rpm
Acoustic pressure	70dBA

**1.6 DIMENSIONS OF THE MACHINE**

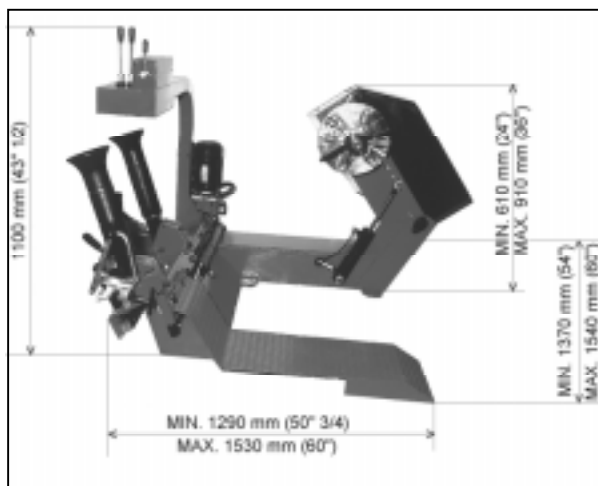

Fig. 2

**1.7 STANDARD ACCESSORIES**

**#10001418 Bead lifting tool** (Fig.3).  
To lift tire bead.

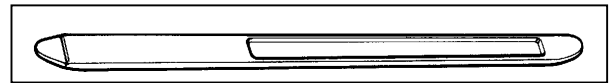

Fig.3

**#14021100 Star flange 220-280mm**(Fig.4).  
To hold rims with a center hole of 220 mm (8.66") and 280 mm (11.02").  
Description on use is in section 5.1.C.



Fig.4

**#14021101 Centering flange 220-280mm** (Fig.4-a)  
Dual diameter flange fitted to the chuck plate to center rims with a center hole of 220 mm (8.66") and 280 mm (11.02").

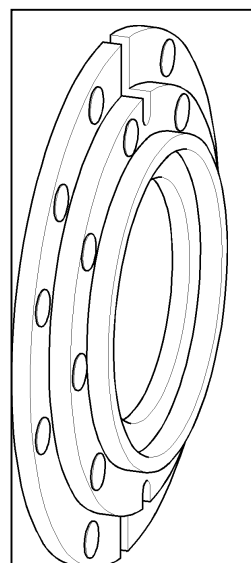

Fig.4-a

**#14021053 Wing nut** (Fig.5).

To lock star flange and rim in place.

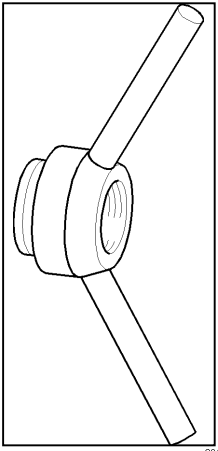

Fig.5

**#14009472 Mounting clamp** (Fig.6).

To hold the bead when mounting tires on steel rims.  
Description on use is in section 5.4.

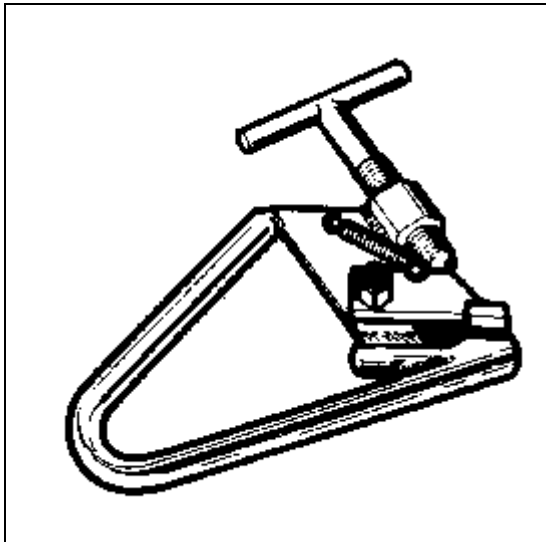

Fig.6

**1.8 ACCESSORIES ON REQUEST**

**#14015339 Clamp for lighth-alloy rims** (Fig.7).

To hold the bead when mounting tires on light alloy rims.

Description on use is in section 5.4.

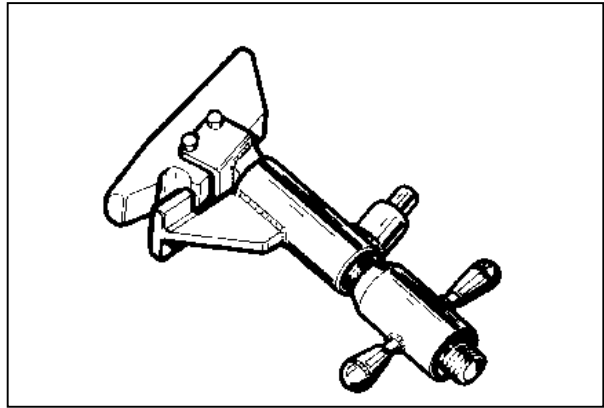

Fig.8

**#14021247 Cone flange**(Fig.8)

To center and hold rims with a center hole of 5.31" - 6.57" (135-167 mm).

Description on use is provided in section 5.3.

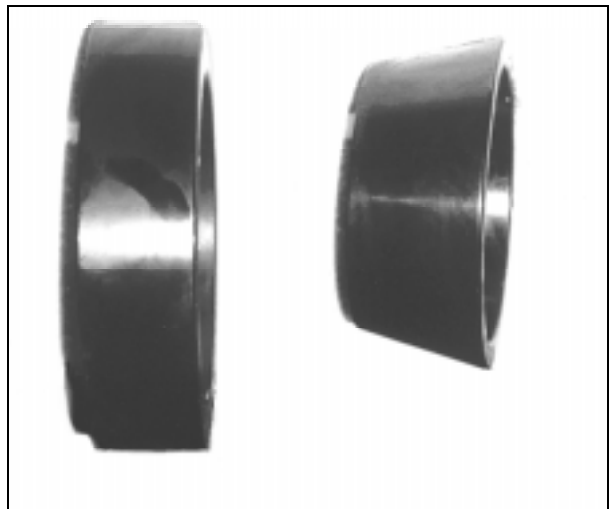

Fig.9

**#14020798 Star flange 164mm (Fig.8-a).**

To hold rims with a center hole of 164 mm (6.46").  
Description on use is in section 5.2.



Fig.8-a

**1.9 SAFETY PRECAUTIONS**

**A. DURING THE USE AND MAINTENANCE OF THE MACHINE IT IS MANDATORY TO COMPLY WITH ALL LAWS AND REGULATIONS FOR ACCIDENT PREVENTION.**

**B. THE ELECTRIC POWER SOURCE MUST HAVE A GROUND CABLE AND THE GROUND CABLE OF THE MACHINE (YELLOW WITH GREEN) MUST BE CONNECTED TO THE GROUND CABLE OF THE POWER SOURCE.**

**C. BEFORE ANY MAINTENANCE OR REPAIRS ARE ACCOMPLISHED THE MACHINE MUST BE DISCONNECTED FROM THE ELECTRIC SUPPLY.**

**D. NEVER WEAR TIES, CHAINS OR OTHER LOOSE ARTICLES WHEN USING, MAINTAINING OR REPAIRING THE MACHINE. LONG HAIR IS ALSO DANGEROUS AND SHOULD BE KEPT UNDER A HAT. THE USER MUST WEAR PROPER SAFETY ATTIRE IE; GLOVES, SAFETY SHOES AND GLASSES.**

**E. MAINTAIN ALL ELECTRIC CORDS IN GOOD REPAIR.**

**F. KEEP SAFETY FEATURES IN PLACE AND IN WORKING ORDER.**

**G. KEEP WORKING AREA CLEAN. CLUTTERED AREAS INVITE ACCIDENTS.**

**H. AVOID DANGEROUS ENVIRONMENTS. DON'T USE POWER TOOLS OR ELECTRICAL EQUIPMENT IN DAMP OR WET LOCATIONS, OR EXPOSE THEM TO RAIN.**

**J. KEEP THE WORK AREA WELL LIGHTED.**

**1.10 SAFETY DEVICES**

This machine has several protectors made of plastic to prevent compression or crushing hazards. The rotation speed of the chuck has been limited to a maximum of 4 rpm to prevent dragging or entrapping hazards.

## 2.0 CARRIAGE INSTRUCTIONS

The machine is crated in a wooden box of appropriate strength.  
The box is mounted to the pallet.  
Handling of the machine must be made with an appropriate lifting device (fork lift) (Fig.9).

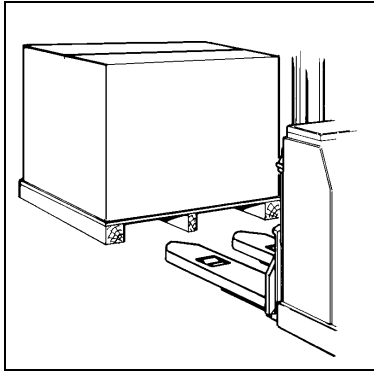
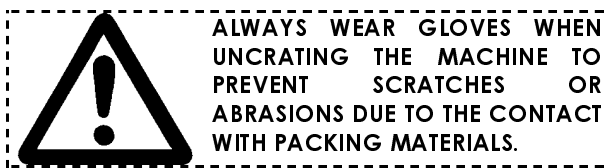

Fig.9

## 2.1 UNCRATING INSTRUCTIONS

Uncrate the machine paying attention when removing the nails or during any other operation which may be hazardous.  
After removing the crate check for any visible damage to the machine and its components.  
In case of doubts call qualified personnel for assistance.  
The packing materials (plastic bags ,polystyrene, nails, screws, wood etc.) must be properly disposed of.  
Place the above mentioned materials into a trash container and dispose per local regulations.



## 2.2 INSTALLATION AREA

Install the machine in a covered and dry area.  
The installation of the machine requires a free space of at least 12'x12' (350x350 cm) (Fig.10).

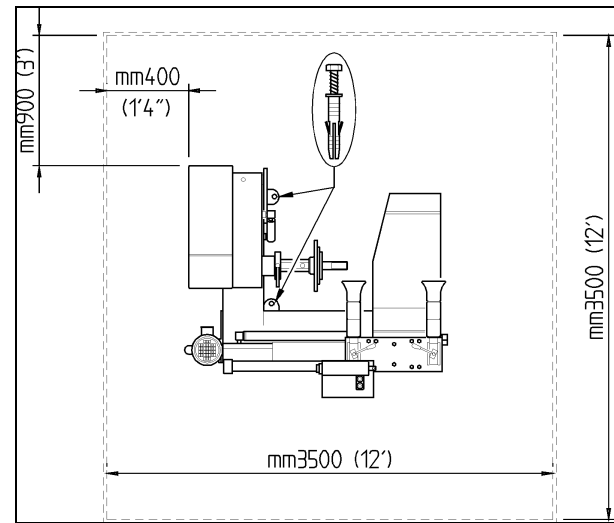

Fig.10

Make sure that from the operating position the user can see all of the machine and the surrounding area.  
The operator shall forbid, in such an area, the presence of non authorized persons and of objects which may create possible hazards.  
The machine shall be installed on a horizontal floor preferably even. Do not install the machine on a sinking or irregular floor.  
In case the machine is installed on a raised floor or on a service vehicle the floor must have a capacity of at least 110 lbs x sqft (5000 N/m<sup>2</sup> or 500 kg/m<sup>2</sup>).

The machine must be secured to the floor through the holes provided in the cabinet. Expansion screws 12x120 mm (or bolts 12X80mm) shall be used.  
Drill 12 mm holes in the floor in correspondence of the holes provided for in the cabinet.  
Place the nogs into the holes drilled in the floor and move the machine sothat the holes of the cabinet are in correspondence of the holes in the floor.  
Tighten the screws at 51 ft·lb (70 Nm).



### 3.0 INSTALLATION INSTRUCTIONS

To install the machine proceed as follows:

- A.** Move the control arm to a vertical position. Install the lock bolt and tighten the nut properly. Make sure that the electric cable and hydraulic hoses are not caught nor damaged. (Fig.11).

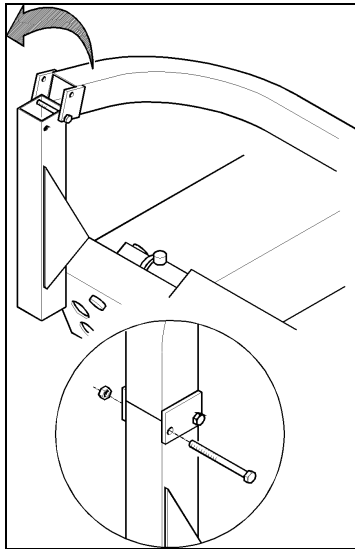

Fig.11

- B.** Install the accessories peg and lock with screw(Fig.11).
- C.** Remove the screws that secure the machine to the pallet . Lift the machine with a belt or a rope of appropriate strength and length (300 cm - 10') (Fig.12).

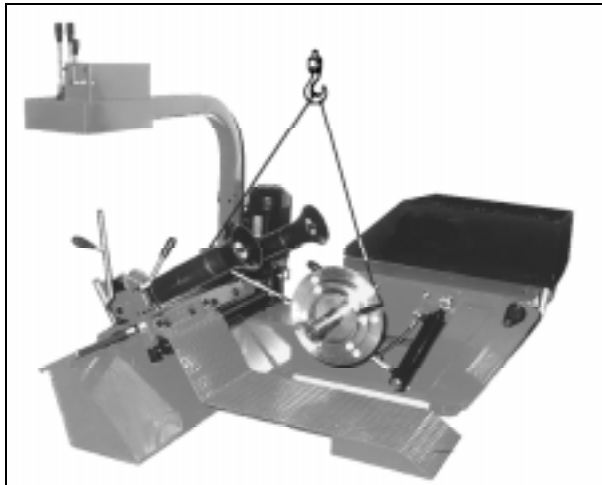

Fig.12

- D.** Remove the lifting aid screw (Fig.13).

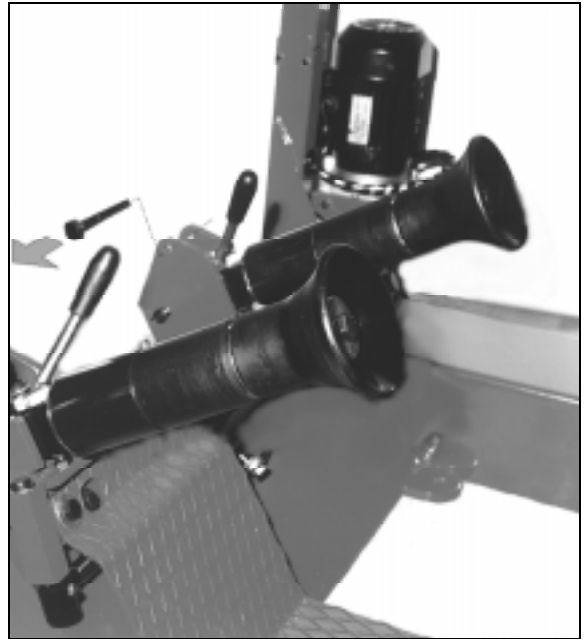

Fig.13

- E.** Place the accessories onto the support provided.



**DO NOT SWING THE MACHINE WHEN LIFTED.**

### 3.1 ELECTRIC INSTALLATION

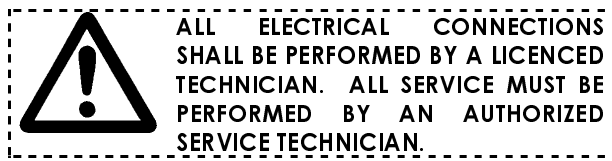

Check on the plate of the machine that the electrical specifications of the power source are the same as the machine.

The machine uses 220VAC, 60Hz, 1Ph, 30 Amp.

Electrical specifications are clearly marked on a label at the end of the electric cord.

Before connecting the machine to the power source, check that the power supply has an efficient grounding system.

There should be less than 1  $\Omega$  between the ground pin and earth ground.

**NOTE:**

The outlet installation must be verified by a licensed electrician before connecting the tire changer.

**NOTE:**

The yellow with green wire in the cord is the grounding wire.

Never connect the grounding wire to a live terminal.

Check that the power supply has an automatic circuit breaker with a differential circuit set at 30 mA.

The electric motor operates in a wide voltage range (plus 10% - minus 7%) and frequency range (60 cycles) and has a class of insulation suitable for hot and moist climates.

#### 4.0 CONTROLS

Before operating the machine ensure that you have well understood the operation and function of all the controls.

- A.** To turn the machine on, rotate the ON/OFF switch to position **1**: the pump motor starts turning and remains in operation until when the machine is turned off. The power required is minimum when the hydraulic cylinders are not in use.

**NOTE:**

IT IS SUGGESTED TO TURN THE MACHINE OFF AFTER EVERY MOUNTING OR DEMOUNTING OPERATION, IF THE TIME BEFORE THE NEXT OPERATION IS LONGER THAN 5 MINUTES.

- B.** Operate the chuck rotation switch (#1 Fig.14) to the right : the chuck rotates clockwise.

Operate the chuck rotation switch to the left : the chuck rotates counter-clockwise.

- C.** Operate the chuck arm control (#2 Fig.14) to position **A** : the chuck arm moves upwards.

Operate the control to position **B** : the chuck arm moves downwards.

- D.** Operate the toolholder carriage control (#3 Fig.14) to position **A** : the carriage moves towards the machine.

Operate the control to position **B** : the carriage moves away from the machine.

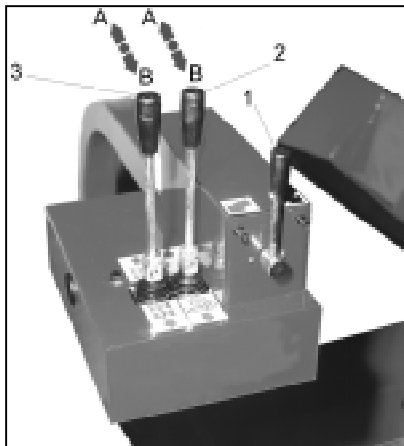

Fig.14

- E.** Use the toolholder arm lock levers (#1 Fig.15) to lock and release the toolholder arms.

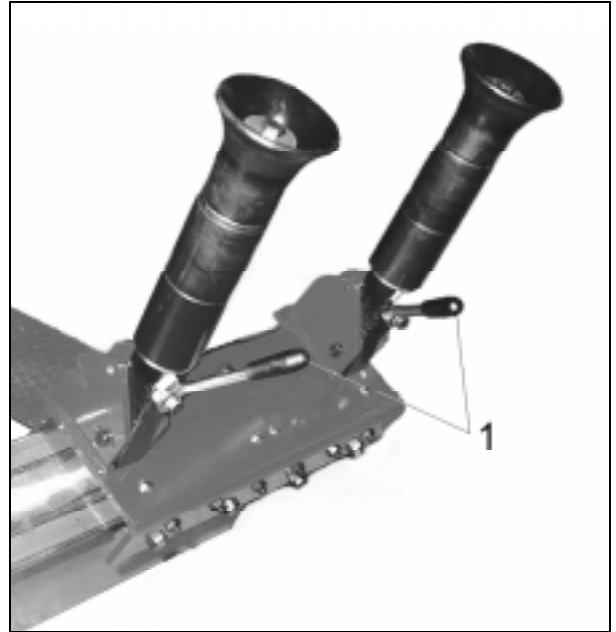

Fig.15

- F.** The hexagonal shaft can be locked in 3 different positions. Operate the chuck shaft lock/release lever (#1 Fig.16) and slide axially the shaft.

Make sure that the shaft is properly locked in position.

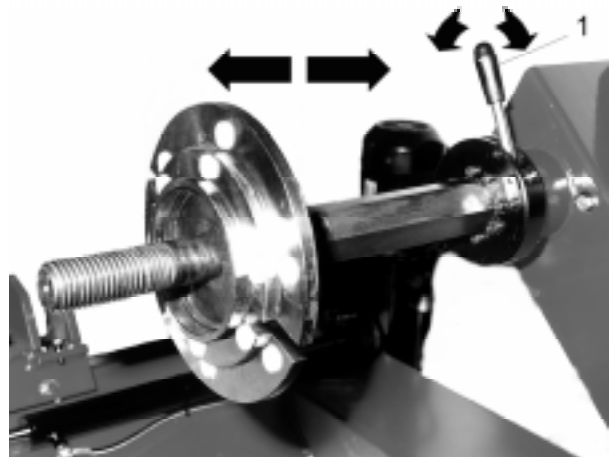

Fig.16

## 5.0 MOUNTING AND DEMOUNTING-GENERAL PRECAUTIONS



**BEFORE MOUNTING A TIRE ON A RIM, PAY ATTENTION TO THE FOLLOWING:**

- A. THE RIM AND ALL ITS PARTS MUST BE CLEAN AND IN GOOD CONDITION: IF NECESSARY CLEAN AND PAINT IT AFTER REMOVING ALL WHEEL-WEIGHTS INCLUDING TAPE WEIGHTS INSIDE THE RIM.**
- B. THE TIRE MUST BE CLEAN AND DRY, WITHOUT ANY DAMAGE TO THE BEAD AND THE CARCASS.**
- C. REPLACE THE RUBBER VALVE STEM WITH A NEW ONE OR REPLACE THE 'O' RING IF THE VALVE STEM IS MADE OF METAL.**
- D. LUBRICATION IS NECESSARY TO MOUNT THE TIRE CORRECTLY AND GET A PROPER CENTERING. BE SURE YOU ARE USING APPROVED LUBRICANT ONLY.**
- E. MAKE SURE THE TIRE IS THE CORRECT SIZE FOR THE RIM.**

## 5.1 LOCKING RIMS WITH A CENTER HOLE OF 220MM AND 280MM

- A.** Move the footboard all the way to the outside. Roll the wheel onto the footboard.
- B.** Move the chuck approximately to the center of the rim. Move the footboard towards the chuck and center the rim on the flange of the corresponding diameter (220mm or 280mm).
- C.** Lock the rim with the wing nut (#2 Fig.17) and the star flange (#1 Fig.17) so that the drive pin is engaged into a bolt hole of the rim.

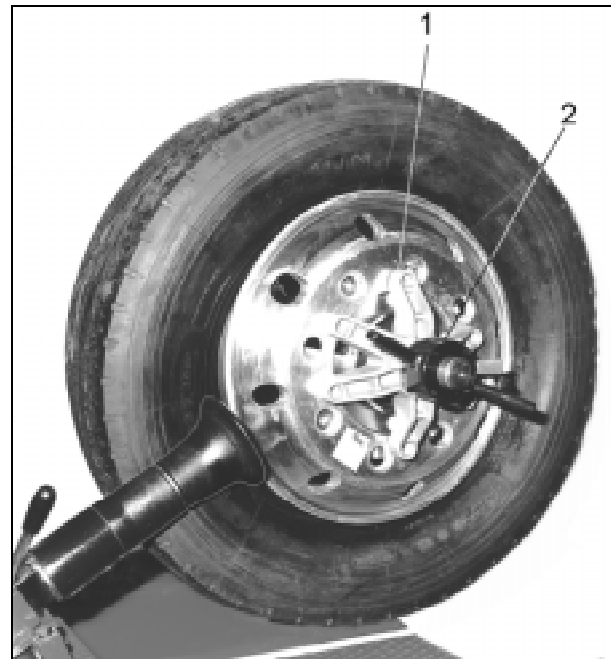

Fig.17

### REMARK:

INSTALL THE DRIVE PIN ON THE STAR FLANGE INTO THE INNER DIAMETER HOLE FOR RIMS WITH A CENTER HOLE OF 220MM.

INSTALL THE DRIVE PIN INTO THE OUTER DIAMETER HOLE FOR RIMS WITH A CENTER HOLE OF 280MM.

THE DRIVE PIN CAN BE INSTALLED/REMOVED WITH HAND PRESSURE.

D. Lock the wheel to the chuck with the appropriate flange checking that the drop center of the rim is towards the outside of the machine (Fig.18).

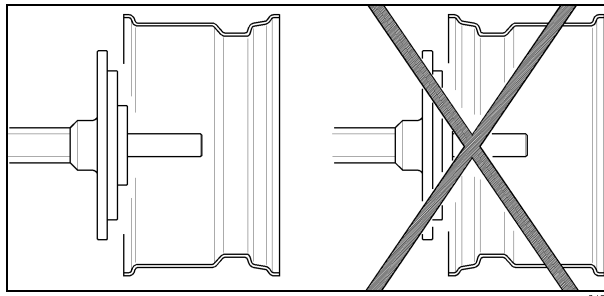

Fig.18

E. Position the shaft of the machine depending on the position of the rim flange (Fig.19 - 20).

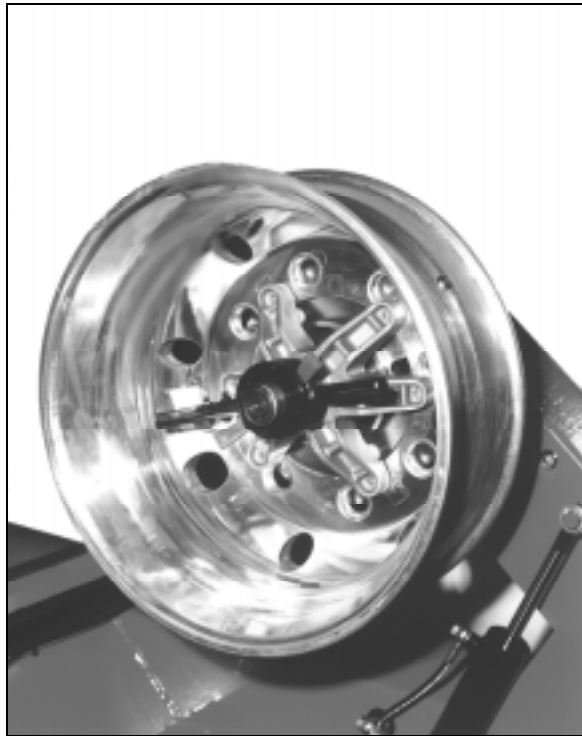

Fig.19



Fig.20

### 5.2 LOCKING RIMS WITH A CENTER HOLE OF 164 MM

To lock this type of rims it is required the appropriate star flange # 14020798 supplied on demand.

- A.** Remove the 280mm flange from the chuck as shown in Fig.21.

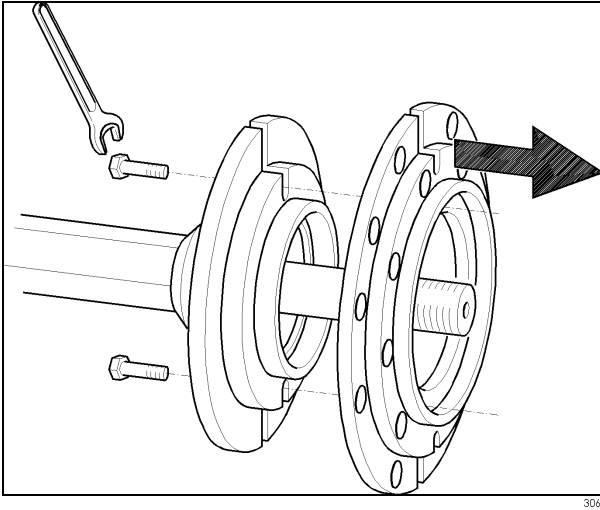

Fig.21

- B.** Lock the rim with the 164mm star flange, as described in section 5.1.

### 5.3 LOCKING RIMS WITH A CENTER HOLE OF 135 ➤ 167 MM

To lock this type of rims it is required the cone flange # 14021247 supplied on demand.

- A.** Mount the spacer ring onto the chuck (Fig.22).

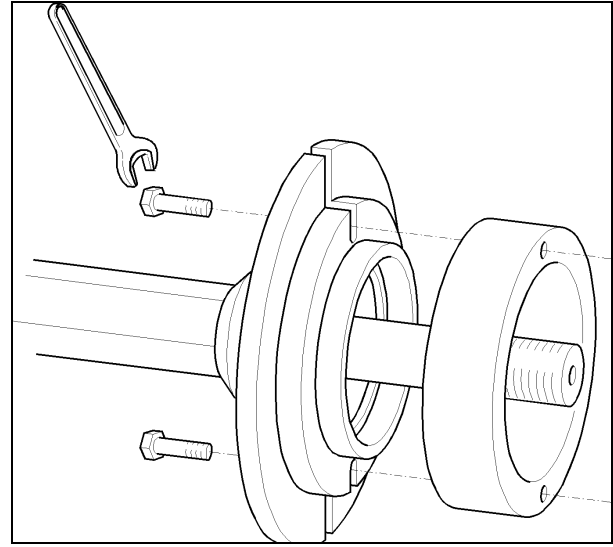

Fig.22

- B.** Lock the rim with the cone from outside following the same procedure described in section 5.1 (Fig.23).

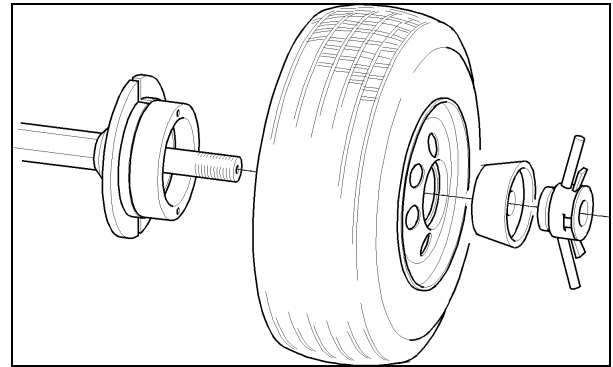

Fig.23

#### 5.4 DEMOUNTING TUBELESS TRUCK TIRES

The tubeless truck tires are mounted on drop-center rims with a conical base. It is possible to demount these tires simply by pressure, with a proper lubrication (Fig.24).

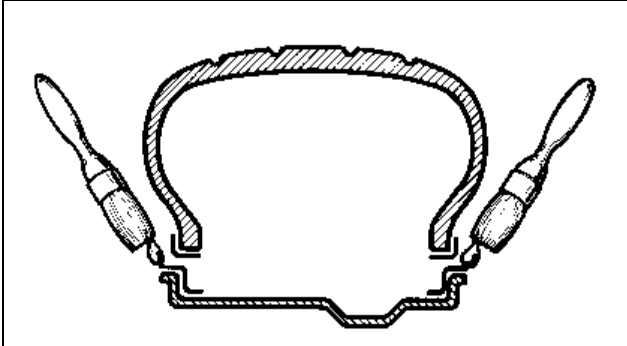

Fig.24

- A.** Remove all wheel-weights from the rim. Remove the valve stem or core and deflate the tire.
- B.** Position the bead breaker roller as shown in Fig.25.



Fig.25

- C.** Lift or lower the chuck so that the bead breaker roller remains close to the rim edge. Turn the chuck counter-clockwise and at the same time move the toolholder carriage step-by-step towards the inside to break the bead. Continue to turn the chuck and lubricate the bead and the rim liberally with an approved lubricant.

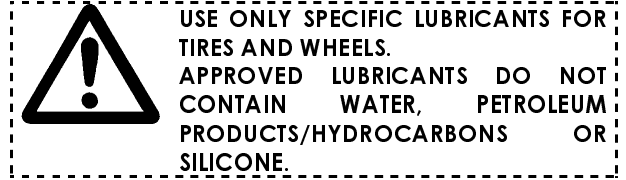

- D.** Lift the outer toolholder arm to idle position. Lower the inner toolholder arm and lock in position.
- E.** Move the toolholder carriage until the roller is in contact with the inner bead.
- F.** Break the inner bead.
- G.** Continue to rotate the chuck while moving the toolholder carriage towards the outside until both beads are demounted from the rim (Fig.26)



Fig.26



**ENSURE THAT THE OUTER BEAD SLIDES INTO THE DROP CENTER OPPOSITE TO THE TOOL, OTHERWISE THE DEMOUNTING OPERATION IS IMPOSSIBLE.**

H. Move to the front of the tire and hold it with both hands in the last part of demounting operation to prevent the tire from falling or rolling away out of control (Fig.27).



Fig.27

### 5.5 MOUNTING TUBELESS TRUCK TIRES

A. Liberally lubricate the entire inner surface of the rim and the tire beads. Attach the mounting clamp (Fig.28) to the outer rim flange with the valve at 11 o'clock and the clamp at 12 o'clock.

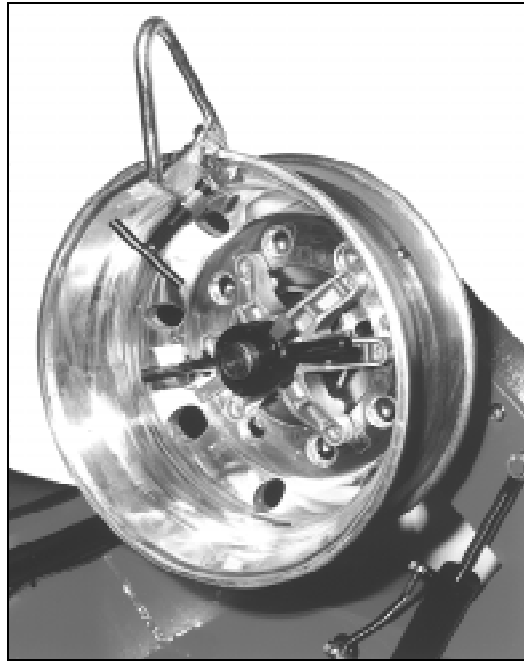

Fig.28

If the rim is made of a light-alloy the rim shape may not allow to attach the standard mounting clamp. In such a case use the light-alloy mounting clamp. The clamp can be used as shown in Fig.29 or 30.



Fig.29





Fig.30



Fig.32

**B.** Move the chuck arm all the way down. Roll the tire on the footboard and hang it onto the mounting clamp (Fig.31).

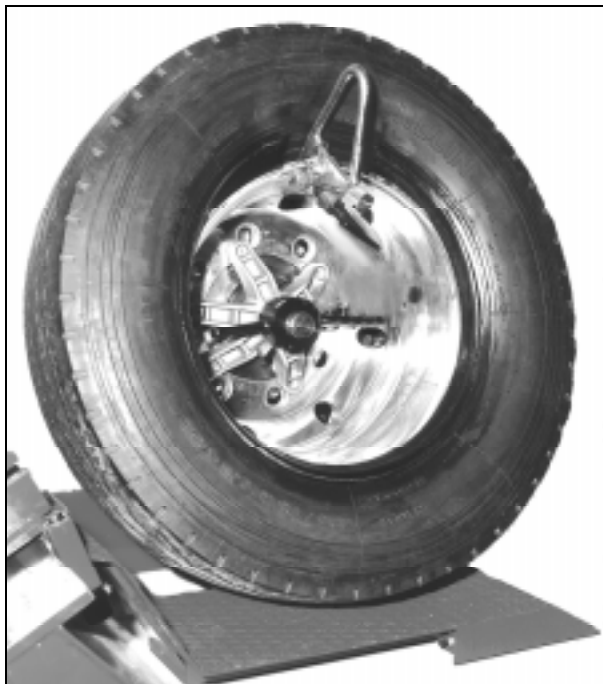

Fig.31

**C.** Lift the chuck arm and position the mounting roller approximately 1.5 cm ( 1/2") to the inside of the rim edge and approx. 1.5 cm ( 1/2") away from the rim edge (Fig.32). The mounting clamp is at 11 o'clock approximately .



**D.** Turn the chuck clockwise until the tire is completely mounted (Fig.33).

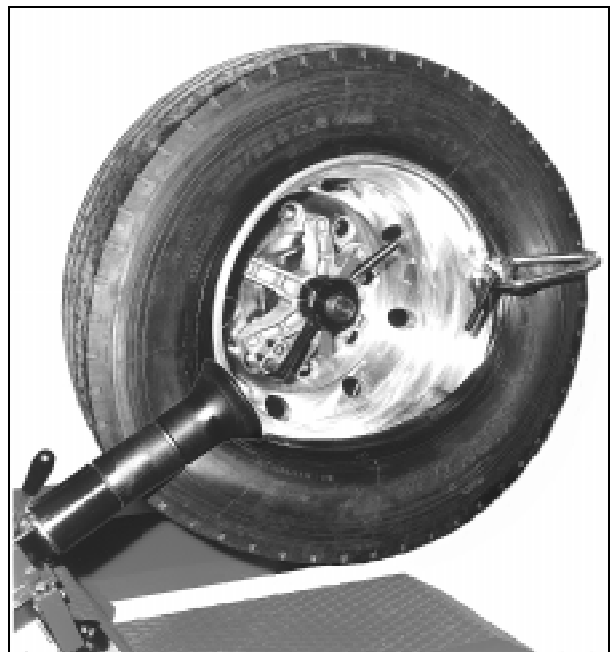





Fig.33

 ENSURE THAT THE OUTER BEAD DESCENDS INTO THE DROP CENTER WHEN THE CLAMP IS OPPOSITE TO THE TOOL.

 STOP THE CHUCK BEFORE ONE COMPLETE TURN IS MADE TO AVOID SERIOUS DAMAGES TO THE MOUNTING CLAMP AND TO THE RIM.

 DO NOT INFLATE THE TIRE ON THE MACHINE. THIS MACHINE IS NOT AN INFLATION DEVICE. FOR INFLATION PLACE THE WHEEL IN AN APPROVED INFLATION RESTRAINT DEVICE (IN THE UNITED STATES OF AMERICA CONSULT O.S.H.A. REGULATIONS CONCERNING THE PROPER SERVICING OF TRUCK, WHEELS AND RIMS).

**6.0 MAINTENANCE**

 BEFORE STARTING ANY MAINTENANCE OPERATION ENSURE THAT NO WHEEL IS MOUNTED ON THE CHUCK AND THAT THE MACHINE IS DISCONNECTED FROM THE ELECTRIC SUPPLY.

- A. Lubricate all points provided with a greasing nipple once a month (Fig.34). Grease the hexagonal shaft once a month.

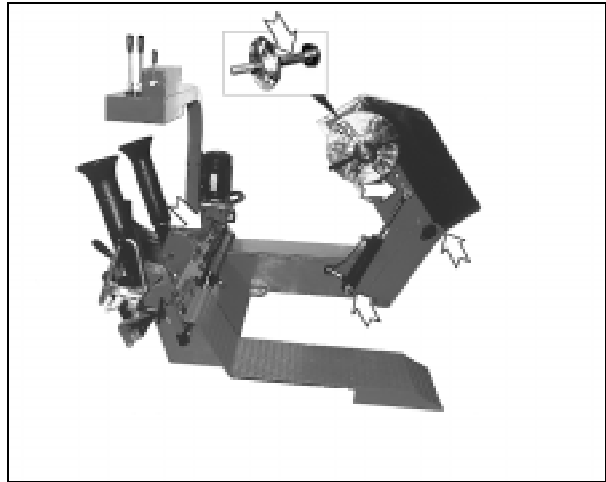

Fig.34

- B. Check hydraulic oil level once a month (Fig.35).

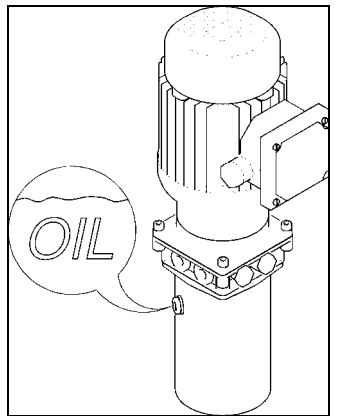

Fig.35

NOTE:  
BEFORE CHECKING, ALL CYLINDERS MUST BE COMPLETELY RETRACTED.

If necessary add:

- ESSO : Nuto H 46
- SHELL : Tellus oil 46
- TOTAL : Azolla 46

Oil change is not required.

## 7.0 MOVING THE MACHINE

In case the machine is to be moved from a working place to another, proceed as follows:

Disconnect the machine from the electric supply.  
Use belts of a length of mm 3000 (10ft) and capacity of kg 500 (1100 lbs).  
Hold the machine as depicted in Fig.36.

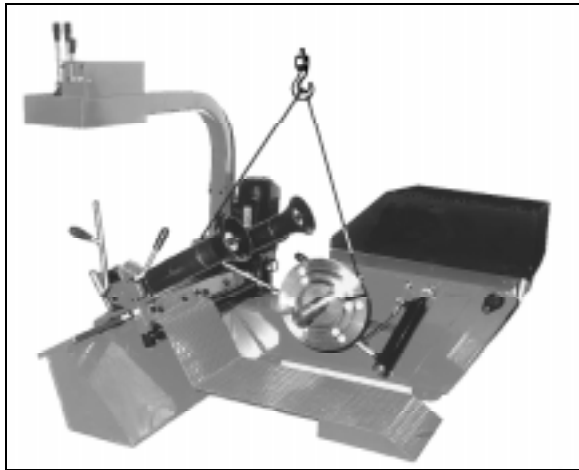

Fig.36

269

## 8.0 PUTTING THE MACHINE OUT OF SERVICE

In case the machine is not to be used for a long period of time (6 months or more) it is necessary to close the chuck arm, retract all hydraulic cylinders and disconnect all power sources. Protect all parts that may be damaged, protect the hydraulic hoses that may be damaged because of a drying process.

When putting the machine back in operation, check first the condition of all previously protected parts, and check for correct functioning of all devices before using the machine again.

## 9.0 SCRAPPING THE MACHINE

Once it is decided to no longer use this machine it is required to make it inoperable by cutting the electric cord.

Considered the machine as a special waste, dismantle the machine into homogeneous parts (metal, plastic, oils etc) and dispose of according to local regulations.

**10.0 TROUBLE SHOOTING**

TROUBLE	CAUSE	REMEDY
When the main switch is turned on the machine does not work.	<ul style="list-style-type: none"> <li>• No electric power.</li> <li>• Switch or motors burnt.</li> </ul>	<ul style="list-style-type: none"> <li>• Check that the electric plug is correctly fitted to the socket and that the electric power is on.</li> <li>• Check that the electric requirements of the machine are the same as the supply.</li> <li>• Call the authorized service center for assistance.</li> </ul>
Pump motor does not turn but the chuck motor is operated normally.	<ul style="list-style-type: none"> <li>• Hydraulic motor burnt.</li> </ul>	<ul style="list-style-type: none"> <li>• Call the authorized service center for assistance.</li> </ul>
Chuck motor does not work properly while pump motor does work.	<ul style="list-style-type: none"> <li>• Switch or chuck motor burnt.</li> </ul>	<ul style="list-style-type: none"> <li>• Call the authorized service center for assistance.</li> </ul>