

# COATS®

## Vero Series™ Wheel Balancer Models V200 2D/3D Wheel Balancers



*Shown with optional accessories.*

See  
★ **Balancing Your  
First Tire**  
on page 3.

### **Safety Instructions** **Set-up Instructions** **Operation Instructions** **Maintenance Instructions**

READ these instructions before placing unit in service. KEEP these and other materials delivered with the unit in a binder near the machine for ease of reference by supervisors and operators.

**HENNESSY INDUSTRIES, INC.**

1601 J. P. Hennessy Drive, LaVergne, TN USA 37086 615/641-7533 800/688/6359 www.ammcoats.com  
HENNESSY INDUSTRIES INC. Manufacturer of AMMCO®, COATS® and BADA® Automotive Service Equipment and Tools.

Manual Part No.: 85608729 02  
Revision: 02/15

# IMPORTANT SAFETY INSTRUCTIONS

## READ ALL INSTRUCTIONS

1. Eye and face protection recommendations:  
“Protective eye and face equipment is required to be used where there is a reasonable probability of injury that can be prevented by the use of such equipment.” O.S.H.A. 1910.133(a) Protective goggles, safety glasses, or a face shield must be provided by the owner and worn by the operator of the equipment. Care should be taken to see that all eye and face safety precautions are followed by the operator. ALWAYS WEAR SAFETY GLASSES. Everyday glasses only have impact resistant lenses, they are not safety glasses.
2. Do not disable hood safety interlock system, or in any way shortcut safety controls and operations.
3. Be sure that wheels are mounted properly, the hub nut engages the arbor for not less than four (4) turns, and the hub nut is firmly tightened before spinning the wheel.
4. Read and understand this manual before operating. Abuse and misuse will shorten the functional life.
5. Be sure the balancer is properly connected to the power supply and electrically grounded.
6. Do not operate equipment with a damaged cord or if the equipment has been dropped or damaged – until it has been examined and repaired by a qualified serviceman.
7. Do not let cord hang over edge of table, bench, or counter or come in contact with hot manifolds or moving fan blades.
8. If an extension cord is necessary, a cord with a current rating equal to or more than that of the equipment should be used. Cords rated for less current than the equipment may overheat. Care should be taken to arrange the cord so that it will not be tripped over or pulled.
9. Keep guards and safety features in place and in working order.
10. Wear proper clothing. Safety toe, non-slip footwear and protective hair covering to contain hair is recommended. Do not wear jewelry, loose clothing, neckties, or gloves when operating the balancer.
11. Keep work area clean and well lighted. Cluttered and/or dark areas invite accidents.
12. Avoid dangerous environments. Do not use power tools or electrical equipment in damp or wet locations, or expose them to rain.
13. Avoid unintentional starting. Be sure the balancer is turned off and power disconnected before servicing.
14. Disconnect the balancer before servicing.
15. Use only manufacturer’s recommended accessories. Improper accessories may result in personal injury or property damage.
16. Repair or replace any part that is damaged or worn and that may cause unsafe balancer operation. Do not operate damaged equipment until it has been examined by a qualified service technician.
17. Never overload or stand on the weight tray or any part of the balancer.
18. Do not allow untrained persons to operate machinery.
19. To reduce the risk of fire, do not operate equipment in the vicinity of open containers or flammable liquids (gasoline).
20. Adequate ventilation should be provided when working on or operating internal combustion engines.
21. Keep hair, loose clothing, fingers, and all parts of body away from moving parts.
22. Use equipment only as described in this manual.
23. Use only manufacturer’s recommended attachments and accessories.

## SAVE THESE INSTRUCTIONS

## Important Safety Instructions

### Owner's Responsibility

To maintain machine and user safety, the responsibility of the owner is to read and follow these instructions:

- Follow all installation instructions.
- Make sure installation conforms to all applicable Local, State, and Federal Codes, Rules, and Regulations; such as State and Federal OSHA Regulations and Electrical Codes.
- Carefully check the unit for correct initial function.
- Read and follow the safety instructions. Keep them readily available for machine operators.
- Make certain all operators are properly trained, know how to safely and correctly operate the unit, and are properly supervised.
- Allow unit operation only with all parts in place and operating safely.
- Carefully inspect the unit on a regular basis and perform all maintenance as required.
- Service and maintain the unit only with authorized or approved replacement parts.
- Keep all instructions permanently with the unit and all decals/labels/notices on the unit clean and visible.
- Do not override safety features.

### Operator Protective Equipment

Personal protective equipment helps make tire servicing safer. However, equipment does not take the place of safe operating practices. Always wear durable work clothing during tire service activity. Loose fitting clothing should be avoided. Tight fitting leather gloves are recommended to protect operator's hands when handling worn tires and wheels. Sturdy leather work shoes with steel toes and oil resistant soles should be used by tire service personnel to help prevent injury in typical shop activities. Eye protection is essential during tire service activity. Safety glasses with side shields, goggles, or face shields are acceptable. Back belts provide support during lifting activities and are also helpful in providing operator protection. Consideration should also be given to the use of hearing protection if tire service activity is performed in an enclosed area, or if noise levels are high.

## Definitions of Hazard Levels

Identify the hazard levels used in this manual with the following definitions and signal words:

### DANGER

Watch for this symbol:



It Means: Immediate hazards, which will result in severe personal injury or death.

### WARNING

Watch for this symbol:



It Means: Hazards or unsafe practices, which could result in severe personal injury or death.

### CAUTION

Watch for this symbol:



It Means: Hazards or unsafe practices, which may result in minor personal injury or product or property damage.



Watch for this symbol! It means BE ALERT! Your safety, or the safety of others, is involved!

**Safety Notices and Decals**



Failure to follow danger, warning, and caution instructions may lead to serious personal injury or death to operator or bystander or damage to property. Do not operate this machine until you read and understand all the dangers, warnings and cautions in this manual. For additional copies of either, or further information, contact:

**Hennessy Industries, Inc.**

1601 JP Hennessy Drive  
LaVergne, TN 37086  
(615) 641-7533 or (800) 688-6359  
www.ammcoats.com



The motor unit of this machine contains a Class IIIa laser with a maximum output less than 5mW at a wave length of 630-680 nm. **Avoid Exposure - Laser radiation is emitted from its aperture.**



Use of controls, adjustments or performance of procedures other than those specified herein may result in hazardous radiation exposure.

In case of failure, the entire motor unit must be replaced.

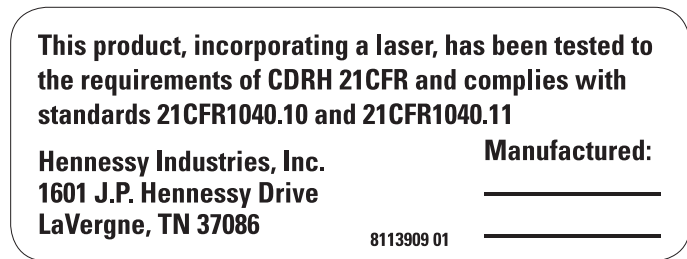

# **WARNING**

**Maximum Size of Wheel Rating**  
**Weight      Diameter      Width**  
**160 lbs.    44 in.    20 in.**

**Maximum Duty Cycle**  
**30 Wheels/Hour @ 160 lbs.**

# **AVERTISSEMENT**

**Capacité de la Dimension  
Maximale de la Roue**  
**Poids      Diamètre      Largeur**  
**73Kg    111,8cm    50,8cm**  
**Cycle de Service Maximum**  
**30 Roues/Heure @ 73Kg**

85609977 00

## Standard Safety Devices

- STOP key for stopping the wheel under emergency conditions.
- A hood guard of high impact plastic that is designed to prevent the counterweights from flying out in any direction except towards the floor.
- A hood switch interlock system that prevents the machine from starting if the guard is not lowered and stops the wheel whenever the guard is raised.

# **WARNING**

## **Risk of Injury**

This machine is provided with a wheel guard interlock. Do not defeat it's purpose.

8111840 02

# **AVERTISSEMENT**

## **Danger de Blessures**

Cet appareil est livré avec un verrouillage du garde de la roue. Ne nuisez pas à son fonctionnement.

8111840FR 02

## **WARNING**

### **RISK OF EXPLOSION**

This equipment has internal arcing or sparking parts which should not be exposed to flammable vapors. Do not locate in a recessed area or below floor level.

### **THIS EQUIPMENT MUST BE EARTH-GROUNDED**

The earth-ground connector built into the power cord provides protection to reduce the risk of electrical shock.

## **AVERTISSEMENT**

### **RISQUE D'EXPLOSION**

Cet équipement possède des pièces internes, pouvant lancer des arcs ou jeter des étincelles, et qui ne devraient pas être exposées à des vapeurs inflammables. Ne situez pas l'équipement dans des endroits encastrés ou en-dessous du niveau du plancher.

### **CET ÉQUIPEMENT DOIT ÊTRE MIS À LA TERRE**

Le raccord de mise à la terre incorporé dans le cordon de puissance fournit une protection afin de réduire le risque d'électrocution.

## **CAUTION**

Do not use below garage floor or grade level.

Disconnect power before servicing this equipment.

To prevent electrical shock, do not remove cover. No user servicable parts inside. Refer servicing to qualified service personnel.

## **ATTENTION**

N'utilisez pas en-dessous du plancher du garage ou du palier.

Débranchez le cordon de puissance avant de faire l'entretien de cet équipement.

Afin de vous protéger contre l'électrocution, n'enlevez pas le couvercle. Aucune pièce interne ne nécessite d'entretien par l'utilisateur. Référez l'entretien à un personnel de service qualifié.

0112027 05

# Table of Contents

<b>Important Safety Instructions</b> .....	<b>iii</b>	<b>Balancing A Wheel</b> .....	<b>16</b>
Owner's Responsibility .....	iii	Dynamic Balancing .....	16
Operator Protective Equipment .....	iii	Static Balancing .....	16
Definitions of Hazard Levels .....	iii	<b>Corrective Weight Placement</b> .....	<b>17</b>
Safety Notices and Decals .....	iv	Behind Spoke Mode .....	17
Standard Safety Devices .....	v	ProBalance™ Technology .....	18
<b>Set Up Instructions</b> .....	<b>1</b>	<b>Calibration</b> .....	<b>19</b>
Receiving .....	1	Machine Calibration .....	19
Electrical Requirements .....	1	<b>Maintenance Instructions</b> .....	<b>20</b>
Machine Set Up .....	1	<b>Diagnostic Procedures</b> .....	<b>20</b>
Floor and Space Requirements .....	1	After Balance Vibration Problems .....	20
Connect to Power .....	1	Troubleshooting .....	21
<b>Accessory Options</b> .....	<b>2</b>	<b>Glossary</b> .....	<b>22</b>
<b>Specifications</b> .....	<b>2</b>		
<b>Features</b> .....	<b>2</b>		
<b>★Balancing Your First Tire</b> .....	<b>3</b>		
<b>Principle Operating Parts</b> .....	<b>4</b>		
Know Your Unit .....	4		
Power Switch .....	5		
Weight Tray .....	5		
Using The Offset Arm .....	6		
Using The Laser Locator .....	7		
Using The Line Laser .....	7		
Hood (Wheel Guard) .....	8		
Using the Hood Sonar (Width Sensor) .....	8		
Auto Wheel Positioning .....	8		
Laser Guided Operation™ System .....	8		
Touchscreen .....	9		
<b>Touchscreen Layout</b> .....	<b>10</b>		
User Interface (UI) Function and Review .....	10		
<b>Mounting Wheel On Balancer Shaft</b> .....	<b>12</b>		
Standard Back Cone Mounting .....	12		
Standard Front Cone Mounting .....	13		
Alternate Mounting .....	13		
<b>Direct Select™ Weight Location</b> .....	<b>14</b>		
<b>Setting Wheel Dimensions (DIM)</b> .....	<b>14</b>		
Definition of Dimensions (DIM) .....	14		
Basic Wheel Data Entry .....	15		
Entering Wheel Dimensions Manually .....	15		



## Set Up Instructions

### Receiving

The shipment should be thoroughly inspected as soon as it is received. The signed bill of lading is acknowledgement, for the carrier, of receipt in good condition of the shipment covered by our invoice.

If any of the goods called for on this bill of lading are shorted or damaged, do not accept them until the carrier makes a notation of the shorted or damaged goods on the freight bill. Do this for your own protection.

NOTIFY THE CARRIER AT ONCE if any hidden loss or damage is discovered after receipt and request him to make an inspection. If the carrier will not do so, prepare an affidavit to the effect that you have so notified the carrier (on a certain date) and that he has failed to comply with your request.

IT IS DIFFICULT TO COLLECT FOR LOSS OR DAMAGE AFTER YOU HAVE GIVEN THE CARRIER A CLEAR RECEIPT.

File your claim with the carrier promptly. Support your claim with copies of the bill of lading, freight bill, invoice, and photographs, if possible.

Although COATS responsibility ceases upon delivery of the shipment to the carrier, we will gladly assist in tracing lost shipments. Our willingness to assist in every possible manner does not make COATS responsible for collection of claims, or replacement of lost or damaged materials.

### Electrical Requirements

See serial tag for the appropriate power requirements of your machine.

Always have a qualified electrician install the proper receptacles in accordance with state and local codes.

### Machine Set Up



**Do not use the touchscreen assembly, faceplate, hood or stub shaft to lift the balancer. Use help to remove the balancer from the pallet. The unit is heavy and the weight is not evenly distributed. Dropping the unit may cause personal injury or equipment damage.**



**Do not attempt to install and set up the unit yourself. Contact COATS as noted below.**

A factory trained COATS Service Technician must perform the install, set up, and initial test procedures on your wheel balancer. Do not attempt to install and set up the unit yourself. Accurate and reliable operation of your unit depends on proper installation. Please contact COATS directly at 1-800-688-9240 for the Certified Service Partner nearest you.

### Floor and Space Requirements

The balancer must be located on a flat floor of solid construction, preferably concrete. The balancer must sit solidly on its three feet. If the balancer is not level, does not sit solidly on its three feet, or is placed on an unstable floor, the balancer will not function properly and may produce inaccurate balance readings.

Do not operate the balancer while it is on the pallet.

Select a location for the balancer that provides a level, solid floor, and adequate clearance around and above the balancer. Make sure the location selected has enough room above and behind the unit so the hood can be raised completely. The location must also provide working room for mounting and removing wheels. Make sure the area has adequate lighting.

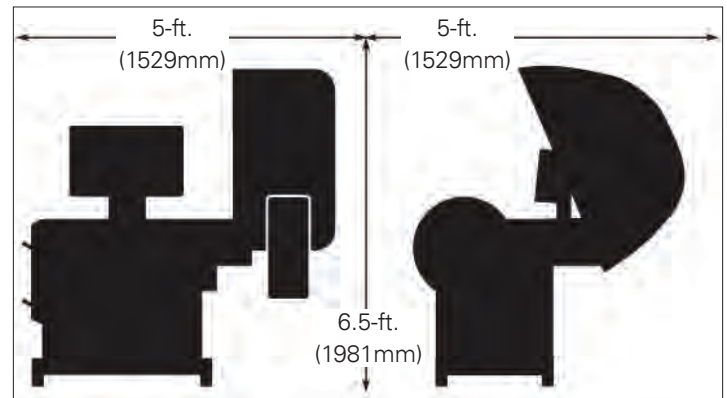

Figure 1 - Space Requirements

### Connect to Power

Your factory trained COATS® Service Technician should do the final check to verify the power installation before connecting the balancer to a power supply. Failure due to improper power connection may void the warranty.

## Specifications

### Wheel Diameter Range

8 - 30 inches (203 - 762 mm)

### Wheel Width Range

2 - 20 inches (51 - 508 mm)

### Maximum Outside Tire Diameter

Up to 44 inches (1118 mm)

### Maximum Tire/Wheel Weight

160 pounds (73 Kg)

### Mounting Shaft Diameter

40 mm

### Resolution (Round Off Mode)

0.25 ounce, position 1.40 degrees

### Resolution (Fine Mode)

0.01 ounce, position 1.40 degrees

### Balancing Display Increments

0.25 or 0.01 ounces

### Electrical Requirements

230V, 1 PH, 60 Hz, 20A  
NEMA L6-20R

230V, 3 PH, 60 Hz, 20A  
NEMA L15-20R

(use grounding type plug)

### Footprint

Width: 60 inches (1524 mm)

Depth: 60 inches (1524 mm)

Height: 78 inches (1981 mm)

### Shipping Weight

650 pounds (295 Kg)

(without accessories)

## Features

- Direct Drive System
- ProBalance™ Technology
- Direct Select™ Weight Placement
- Behind the Spoke Weight Placement
- Automatic Start When Hood Is Lowered
- Automatic Data Entry for Offset, Diameter & Width - Manual Entry Backup on all Parameters
- Simple, Interactive User Interface - Touchscreen
- Operator Memory for Two Different Users
- Static, Dynamic And Multiple Tape-A-Weight®
- Laser Guided Operation™ System
- Auto Wheel Positioning
- Hood Safety Interlock System
- MET Lab Listing

<b>Accessory Options</b>		Basic Pro	Extended Pro	Premium Pro
Description	Part Number	85609487	85609488	85609489
Stub Shaft	8500920401	x	x	x
Bracket/Peg Accessory	8111054	x	x	x
Weight Tray Stud (6 included)	85608850	x	x	x
8 Double Sided Collets	85609499	x	x	x
Calipers	8309011	x	x	x
Premium Wheel Weight Hammer	8113175	x	x	x
Premium Quicknut	85607503	x	x	x
Small Pressure Cup & Rubber Lip	8112106	x	x	x
No Mar Ring	85608312	x	x	x
Spring	8112107	x	x	x
Scraper	8113390	x	x	x
Short Cone	8112421		x	x
Light Cone Kit (4.8" - 6.8")	8113277C		x	x
Faceplate Extension	8111935		x	x
Pin-Plate System with Balancer Mate	8KPPBM40			x



## ★Balancing Your First Tire

- 1. Turn the machine OFF then ON (resets machine).**

**Note:** The machine wakes up using standard clip-on wheel weight locations (Clip 1 & Clip 2) and wheel dimensions.

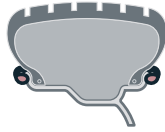

- 2. Mount a tire/wheel on the balancer that will use standard clip-on wheel weights.**

Use the most appropriate mounting method.

- 3. Always remove any weights already attached to the wheel.**

- 4. Enter A & D wheel dimensions using offset arm.**

For Automatic Measurement — pull offset arm out to the wheel, hold it still at clip-on weight position against wheel flange, and wait for BEEP. Return arm to home position.

Clip-on Weight Location — viewed on a cut-away rim for clarification.

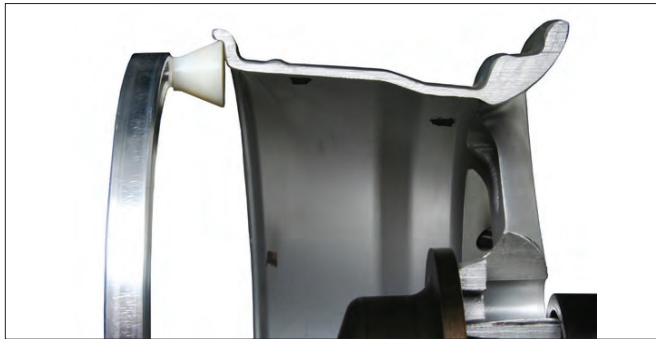

Figure 2 - Clip-On Weight Location

Note the value entry of A & D dimension.

- 5. Enter Width wheel dimension.**

For Automatic Measurement — Lower hood.

For Manual Entry — Use plastic calipers to measure wheel width. Press W icon. Use keypad to enter Width value (between 2.0 and 20.0 inches).

- 6. Lower hood (wheel guard); wheel spins and unbalances are measured and displayed.**

The corrective weight amount appears in the weight display window for inboard and outboard weight locations.

- 7. Raise hood after tire stops rotating.**

**Note:** Wait for wheel to stop before raising the hood (wheel guard).

- 8. Wheel automatically stops at inboard weight position.**

The inboard center bar highlights green.

**Note:** If an inboard corrective weight is not required then go to step 11.

- 9. Attach inboard corrective weight.**

Attach specified weight amount at top-dead-center on inside flange of wheel (clip 1).

- 10. Press NEXT; wheel rotates.**

- 11. Wheel automatically stops at outboard weight position.**

The outboard center bar highlights green.

- 12. Attach outboard corrective weight.**

Attach specified weight amount at top-dead-center on outside flange of wheel (clip 2).

- 13. Lower the hood to respin the tire/wheel and check balance.**

The weight readings should now be 0.00.

**Note:** Throughout this manual tire dimensions are referred to as A, W, and D, see figure 3.

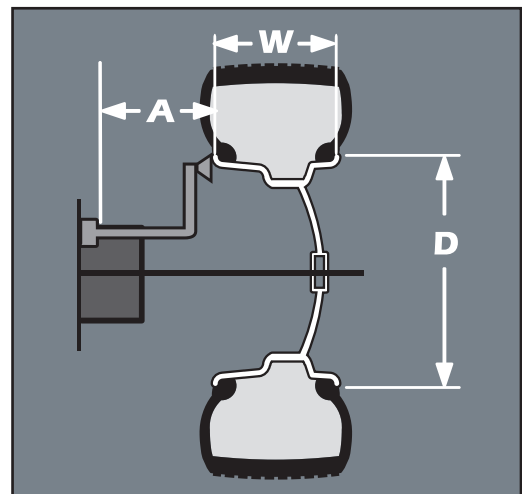

Figure 3 - A, W, and D Tire Dimensions

## Principle Operating Parts

### Know Your Unit

Compare this illustration with the unit before placing it into service. Maximum performance and safety will be obtained only when all persons using the unit are fully trained in its parts and operation. Each user should learn the function and location, of all controls.

Prevent accidents and injuries by ensuring the unit is properly installed, operated and maintained.



- A** - Touchscreen
- B** - ON/OFF Switch (Back Of Machine)
- C** - Plug (Back Of Machine)
- D** - Weight Tray Studs
- E** - Weight Tray with Pockets for Weights
- G** - Hood (Wheel Guard)
- H** - Hood Sonar (Width Sensor), if equipped
- J** - 40 mm Shaft
- K** - Laser Locator
- L** - Offset Arm, Measures A & D of Tire/Wheel (Shown In Home Position)

**Note:** Throughout this manual, wheel weights are referred to as Clip-on or Tape-A-Weight®. Figure 4 shows an example of each weight.



**Clip-on Weight**

**Tape-A-Weight®**

Figure 4 - Corrective Weight Examples. For Best Results, use BADA® Brand Wheel Weights.

## Power Switch

The ON/OFF switch location (figure 5) is on the left side of the balancer; below the weight tray.

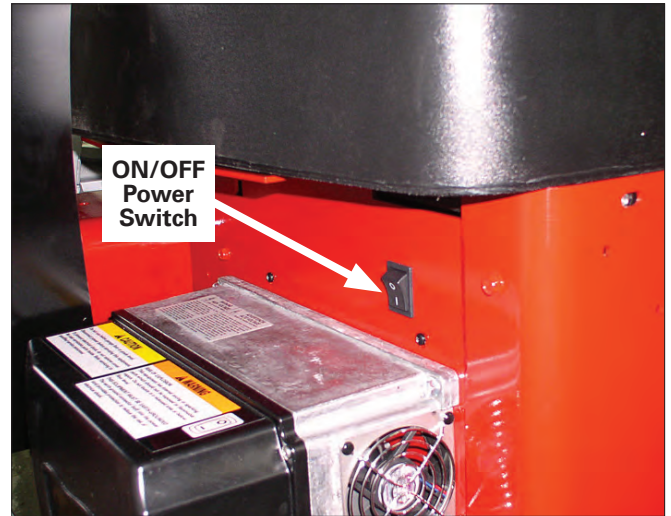

Figure 5 - On/Off Switch

## Weight Tray

Weight pockets are laid out so that wheel weights are easily accessible. Use the weight tray studs for handy storage of wheel mounting adapters.



Figure 6 - Top Down View of Weight Tray With BADA Brand Wheel Weights and COATS® Brand Accessories



## Using The Offset Arm

When not in use or when prompted by the balancer instructions, store the offset arm in the home position as shown in figure 7.

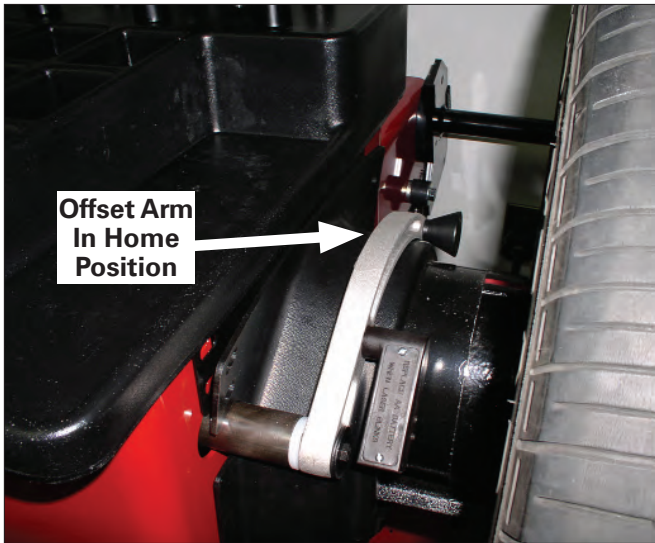

Figure 7 - Location of Offset Arm (Stored In Home Position) and Laser Locator

Use the offset arm gauge (figure 8A) to automatically measure the distance from wheel to machine and the wheel diameter at the point of weight application. Also, use the offset arm for the correct positioning of weight application on the inside rim as indicated by the balancer instructions.



Figure 8A - Automatic A&D Measurement At Clip-on Weight Location

Be sure to place the offset arm on the wheel flange at the clip-on weight location as shown figure 8B.



Figure 8B - Clip-on Weight Location Viewed on a Cut-Away Rim for Clarification.

**Note:** Use the offset arm to automatically measure the A & D dimension for all balancing modes.

**Note:** Refer to page 15 to measure the A dimension manually using the offset arm.

**Note:** The T2 Tape Direct Select™ Weight position is the only mode that requires the A2 & D2 dimension measurements.

**Note:** Use laser locators for correct positioning of the T2 Tape Direct Select™ Weight position, refer to page 7.

If the T2 Tape (hidden Tape-A-Weight®) location is selected, use the offset arm to enter A2 & D2 measurements automatically. After the A & D measurement is entered, move the arm from the clip-on weight location to the inner area of the wheel; up against the rim at the outboard weight placement location (see figures 9A & 9B). Wait for the BEEP.



Figure 9A - Hidden Weight Location Viewed on a Cut Away Rim for Clarification.

**Important:** The A2 measurement must be at least 2 inches greater than the A1 measurement.

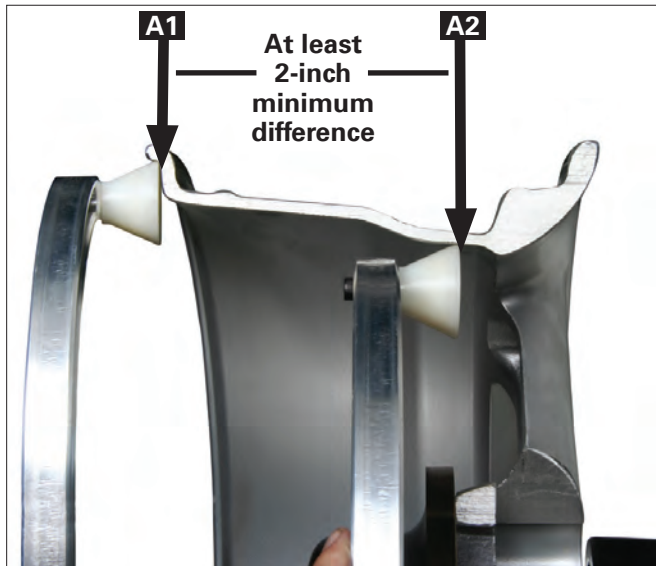

Figure 9B - T2 Tape (Hidden Tape-A-Weight®), Keep At Least 2 inches Between A1 and A2 Measurement

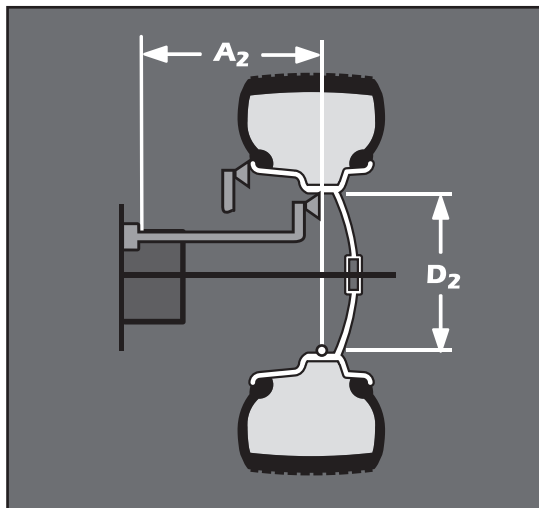

Figure 9C - T2 Tape (Hidden Tape-A-Weight®), Data Entry Diagram

### Using The Laser Locator

If the T2 Tape (hidden Tape-A-Weight®) location is selected, use the laser locator to point to the hidden weight location (figures 10 & 9B). Rotate laser locator knob to position the laser dot outboard at the desired T2 Tape (hidden Tape-A-Weight®) location.

**Note:** For best performance, choose a weight position outboard as far inward (in the rim) as wheel allows.

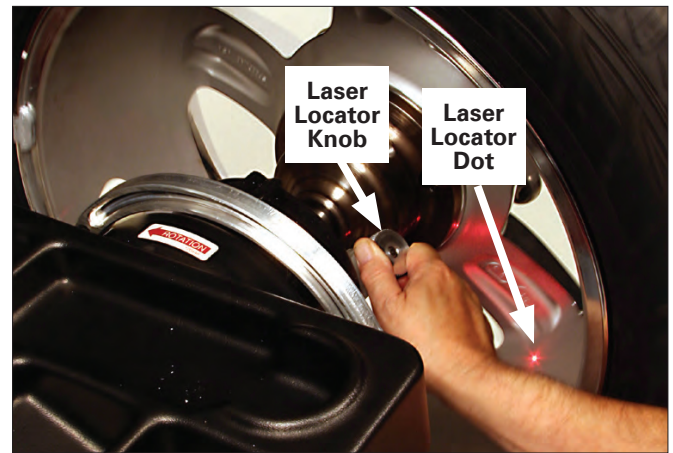

Figure 10 - Positioning Laser Dot At T2 Tape Hidden Weight Location (A2)

**Note:** The T2 Tape Direct Select™ Weight position is the only mode that requires the A2 & D2 dimension measurements.

### Using The Line Laser

If the T2 Tape (hidden Tape-A-Weight®) location is selected, use the line laser to align the offset arm with the laser locator dot (figures 10 & 9B); entering A2 & D2 measurements automatically. Grasp arm at the line laser and pull out and up to the wheel flange (figure 8B). Hold arm still at the clip-on weight location and wait for BEEP. Then, before returning arm to home position, press button on line laser to activate the line laser beam. Move arm to inner area of wheel and align line laser beam with laser locator dot (figure 10). Hold arm still, up against the rim, in the same plane as the T2 Tape (hidden Tape-A-Weight®) location (figure 9A & 9B) and wait for BEEP. Refer to figure 11.

**Note:** The line laser remains on for ten seconds after its button is pushed.

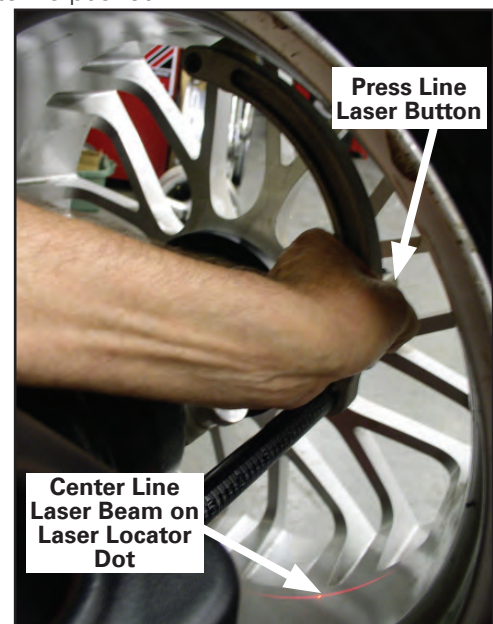

Figure 11 - Positioning Line Laser Beam At T2 Tape Hidden Weight Location (A2)

## Hood (Wheel Guard)



**Never raise up the wheel guard before the wheel has come to a stop. Keep hair, loose clothing, fingers and all parts of body away from moving parts.**

If, due to a fault in the machine, the wheel keeps spinning permanently, switch off the machine at the master switch or by unplugging the plug from the power supply. Wait until the wheel stops before opening the wheel guard.

### Using the Hood Sonar (Width Sensor)

When prompted by the balancer instructions, use the hood sonar (width sensor, figure 12) to enter wheel width measurement automatically. Lower balancer hood to enter the measurement.

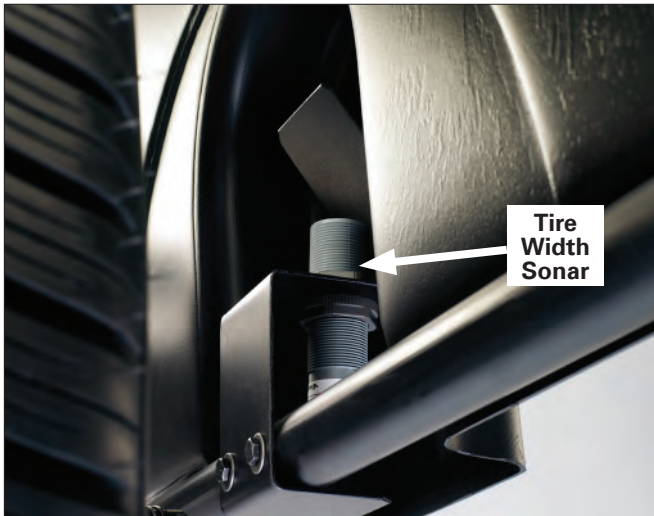

Figure 12 - Tire Width Sonar Located Inside Hood

**Note:** Refer to page 15 to measure the W dimension manually using the plastic calipers.

## Auto Wheel Positioning



**Keep hair, loose clothing, fingers and all parts of body away from moving parts.**

The balancer's auto positioning feature stops the wheel automatically at the corrective weight location. The wheel is spun and unbalances are measured and displayed. The inboard center bar highlights green as the balancer stops the wheel at the inboard corrective weight location (top-dead-center). (If an inboard corrective weight is not required then the wheel will stop at the outboard corrective weight location.) Press NEXT. The outboard center bar highlights green as the wheel automatically moves and stops at the outboard corrective weight location (top-dead-center).

Pressing NEXT moves the wheel automatically to the next corrective weight location. Pressing STOP & EXIT releases the wheel so that it can be manually positioned.

After several minutes of inactivity, the auto positioning feature will turn itself off. Press NEXT to make the feature activate again.

### Laser Guided Operation™ System

The operator must select T2 Tape Laser Locator to activate the Laser Guided Operation™ feature, see page 14 for the button selection. This Direct Select™ weight location is used when placing hidden adhesive weight at the inner area of the wheel and is the required weight location selection for the Behind Spoke mode.

Follow these steps to use the Laser Guided Operation™ feature for accurate placement of hidden Tape-A-Weights®:

**Important:** Only use the Direct Select Weight position Clip 1 or T1 Tape and T2 Tape (location activated). Refer to Using The Offset Arm on pages 6 - 7 and Using The Lasers on page 7.

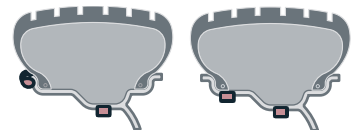

1. Begin by mounting the wheel assembly on the balancer shaft.
2. Direct Select™ T2 Tape as the outboard weight location.

**Note:** The laser locator dot activates and blinks.



**3.** Rotate the laser locator knob to position the laser locator dot at the desired weight location. See figures 10 & 9B.

**Note:** For best performance, choose a weight position outboard as far inward (in the rim) as wheel allows.

**4.** Enter the A & D wheel measurements, wait for BEEP. Then, before returning arm to home position, move arm to inner area of wheel and position the line laser beam at the T2 Tape laser locator dot position; wait for BEEP.

**5.** Lower hood; wheel spins.

**6.** When the inboard unbalance is displayed, the inboard center bar highlights green. Attach inboard corrective weight at top-dead-center.

**Note:** If an inboard corrective weight is not required then the wheel will stop at the outboard corrective weight location.

**7.** Press NEXT to rotate wheel to outboard corrective weight location where the outboard center bar is steady and the two bars on either side blink.

**Note:** The laser locator dot will stop blinking.

**8.** Center and attach the outboard corrective weight at laser locator dot location as shown in figure 13.

**9.** Respin tire/wheel to check balance.

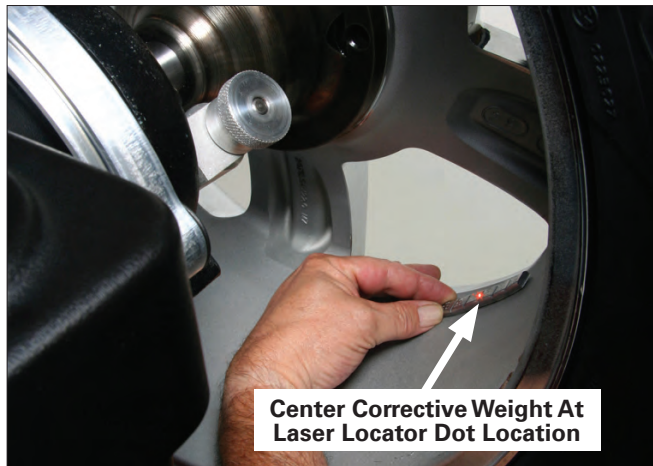

Figure 13 - Centering Corrective Hidden Weight At Laser Locator Dot Location

## Touchscreen

The balancer touchscreen is a resistive touch panel (figure 14). To enter a function, press the appropriate function icon.



Figure 14 - Press Touchscreen Functions

**Note:** Only press the touchscreen with your fingers. Never use the weight hammer or other pointed objects to press on the screen.



## Touchscreen Layout

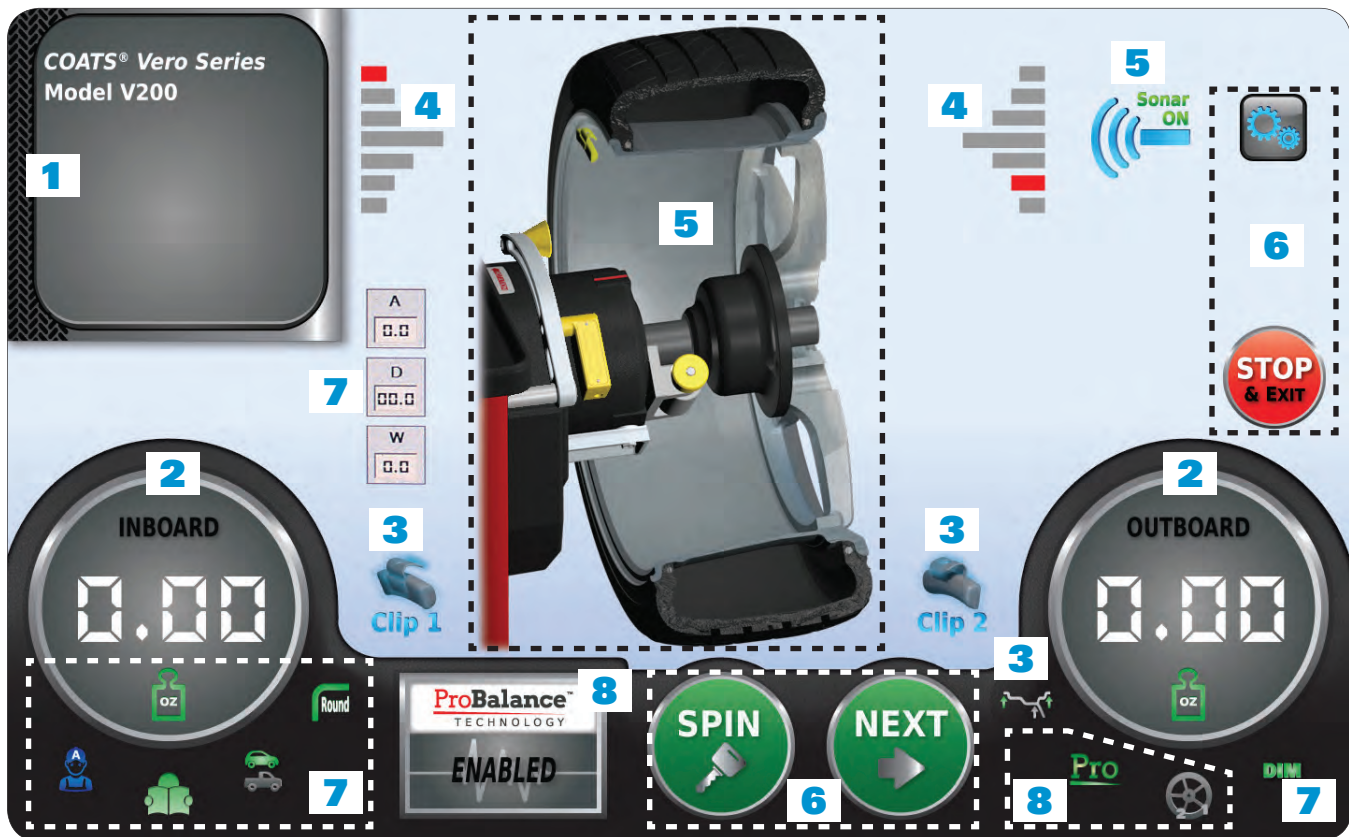

Figure 15 - Model V200 Default Touchscreen Feature Reference

### User Interface (UI) Function and Review







#### 1 Information / Instruction Panel

An information box appears when the operator text assist icon is activated and to display any error messages.

#### 2 Weight Display Dials

Located on either side of the wheel cross-section diagram are the weight position bars, one Inboard and one Outboard. After a measurement cycle, rotate wheel until the center weight position bar blinks, indicating the correct weight placement position is at top-dead-center.

#### 3 Direct Select™ Weight Location Icons & Cross-section Diagram











 or 	Clip 1 or T1 Tape	The activated Inboard weight location on the wheel cross-section diagram.
 ,  , or 	T2 Tape, T3 Tape, or Clip 2	The activated Outboard weight location on the wheel cross-section diagram.
	Direct Select™ Weight Location	Select to go to the Direct Select Weight Location Screen, see page 14.

#### 4 Weight Position Bars

Located on either side of the wheel cross-section diagram are the weight position bars, one Inboard and one Outboard. After a measurement cycle, rotate wheel until the center weight position bar blinks green, indicating the correct weight placement position is at top-dead-center. When in laser mode (T2 Tape Laser Locator), special blinking bars appear on either side of the center bar to indicate the correct outboard weight placement position. Also remember that the laser beam dot will stop blinking when it is at the correct weight placement location.

## 5 Wheel Cross-section Graphic and Indicators

On the main screen, a wheel cross-section graphic indicates the wheel balancer operational status.

	Sonar On or Sonar Off	Indicates whether the width sonar is set on or off.
<b>6 Navigation Icons</b>		
	Settings	Select this icon to access and set additional balancer functions.
	STOP & EXIT	Deactivates a function or error. Also use to release the wheel so that it can be manually positioned.
	SPIN	Lower hood and press this dashboard icon to begin a wheel measurement cycle.
	NEXT	Press this dashboard icon to access additional functions or instructions, such as moving to the next weight location.
<b>7 Balance Option Icons</b>		
	Ounce or Gram	The weight measurement option that is activated. Toggle to select either Ounce (default) or Gram.
	Operator A or Operator B	The Operator Memory option that is activate. Toggle between two operator memories A (default) or B.
	Text Assist On or Text Assist Off	Toggle operation instruction box on or off.
	Passenger Car or RV-Light Truck	The weight increment option that is activated. Toggle to select either 0.25-ounce passenger car (default) or 0.50-ounce RV-Lt Truck (heavy wheels).
	Round Off or Fine	Toggle to select either a 0.25-ounce (default) or 0.01-ounce (fine) weight increment option.
	DIM On or DIM Off	Toggle wheel dimensions on or off (default). See Setting Wheel Dimensions (DIM) on page 14.
<b>8 Balance Mode Icons</b>		
	Dynamic, ProBalance, or Static	The Balance mode that is activated. Scroll to select Dynamic (default), ProBalance, or Static. When enabled, the ProBalance™ Technology icon button indicates any excessive residual unbalance.
	Behind Spoke	Select Behind Spoke mode to activate (turns green). See Behind Spoke on page 17 for further details.
	Machine Calibration	Indicates Machine Calibration mode is activated. See Machine Calibration on page 19 for further details.

## Mounting Wheel On Balancer Shaft



Avoid back injury, seek assistance when lifting heavy tire/rim assemblies onto the balancer shaft.



Failure to tighten the hub nut properly may result in the wheel dismounting, causing personal injury and property damage.

Select the most appropriate mounting method for the wheel you are balancing. Using the proper method ensures secure mounting and safe balancer operation, and prevents damage to the wheel.

On most wheels, the inner side of the wheel hub usually has the most uniform surface for wheel balancing. Always center the wheel by the most uniform shaped side of the hub to achieve the most accurate balance.

Regardless of mounting type, on standard units, always make sure that the wheel is forced firmly against the shaft faceplate and that the hub nut engages the threaded shaft for at least four complete turns. To assist in centering the wheel properly, rotate the wheel and the shaft while tightening the hub nut.

## Standard Back Cone Mounting

Most original equipment and steel wheels can be mounted properly using this method. The wheel is centered on a cone from the inner side of the hub.

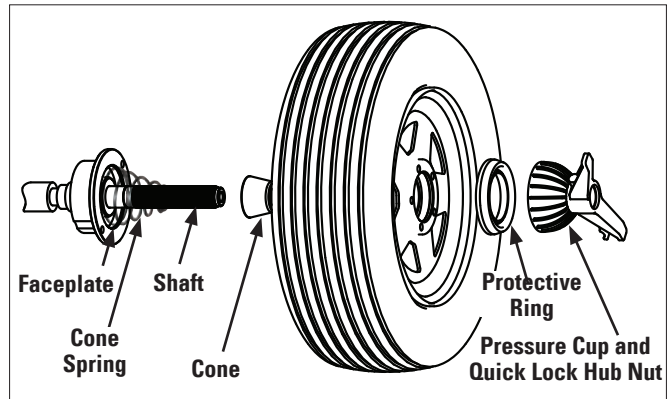

Figure 16 - Standard Back Cone Mounting

1. Place the cone spring onto the balancer shaft with the large end towards the faceplate.
2. Select the cone that best fits the center hole in the wheel. Slide the cone onto the shaft with the large end towards the cone spring.
3. Lift wheel onto the shaft and center it on the cone.
4. Attach pressure cup to hub nut. Install the hub nut assembly onto the shaft and tighten it securely against the wheel. The wheel must be forced firmly against the faceplate. The hub nut must engage the threads for at least four full turns

**Note:** Use a nylon spacer (protective ring) to protect custom wheel finishes.

**Note:** If the hub nut will not tighten completely, use the front cone mounting method.

## Standard Front Cone Mounting

A wheel should be centered by the outer side of the hub only when the inner surface will not provide an accurate surface to center on.

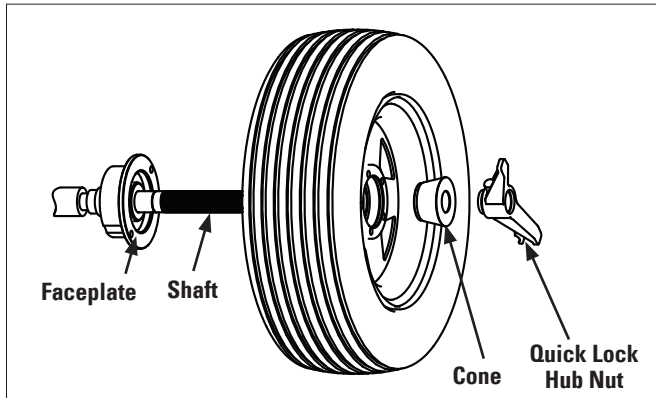

Figure 17 - Front Cone Mounting

- 1.** Select the cone that best fits the center hole in the wheel.
- 2.** Lift the wheel onto the balancer shaft and slide it back against the faceplate.
- 3.** Slide the cone onto the shaft and into the center hole of the wheel. You will need to lift the tire to seat the cone in the center hole.
- 4.** Install the hub nut (without pressure cup) onto the shaft. Tighten it securely against the cone. The hub nut must engage the threads for at least four full turns.

**Note:** If the hub nut will not tighten completely because of a lack of threads, use an additional cone as a spacer between the mounting cone and the hub nut. The wheel must be forced firmly against the faceplate.

## Alternate Mounting

If the wheel has a protruding outer hub which will not permit the use of the pressure cup, or the cup will not permit the hub nut to engage at least four turns of the shaft, this alternate method should be used.

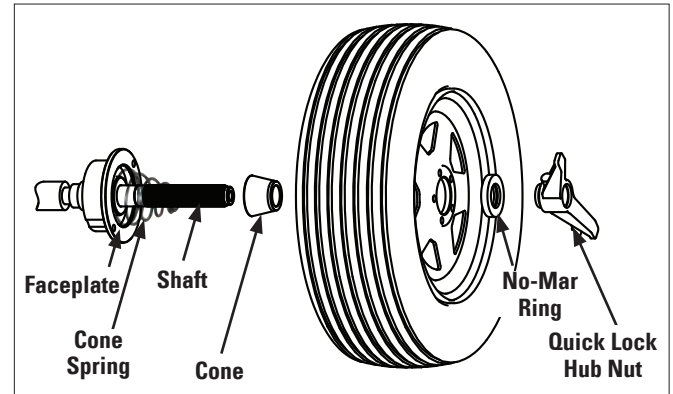

Figure 18 - Alternate Mounting

- 1.** Place the cone spring onto the balancer shaft with the large end towards the faceplate.
- 2.** Select the cone that best fits the center hole in the wheel. Slide the cone onto the shaft with the large end towards the faceplate.
- 3.** Lift wheel onto the shaft and center it on the cone.
- 4.** Use the small nylon spacer (no-mar ring) or a centering cone to press against the outer wheel hub.
- 5.** Install the hub nut (without the pressure cup) onto the shaft. Tighten securely.

## Direct Select™ Weight Location

When the machine is turned ON, the balancer defaults to a 2-plane dynamic mode using standard clip-on wheel weight locations (Clip 1 and Clip 2) and wheel dimensions.

**1.** Before setting wheel dimensions and spinning the wheel, first press the Direct Select Weight Placement icon (see page 10) to go to the Direct Select screen and enter an alternate weight placement location on the wheel as follows:

**Clip 1 (default)** - select this location to place a standard clip weight on the Inboard rim flange.

**T1 Tape** - select this location to place an adhesive weight on the Inboard side of the wheel that is the horizontal plane at the outer edge.

**T2 Tape** - select this location to place an adhesive (hidden) weight on the Outboard side of the wheel that is the horizontal plane in the inner area.

**T3 Tape** - select this location to place an adhesive weight on the Outboard side of the wheel that is the horizontal plane at the outer edge.

**Clip 2 (default)** - select this location to place a standard clip weight on the Outboard rim flange.

**2.** Press EXIT to return to the main screen.



Figure 19 - Direct Select™ Weight Icons & Wheel Cross-section Diagram

## Setting Wheel Dimensions (DIM)

Before a wheel can be balanced, wheel dimensions must be entered into the computer.

### Definition of Dimensions (DIM)

#### A = Offset

The distance measured from the balancer ("0" on offset arm) to inner plane of the rim (inner weight location).

#### W = Width

The width of the wheel at the rim flanges, measured with the calipers as shown in figure 22.

**Note:** Only use calipers provided by the wheel balancer manufacturer because others may be different.

#### D = Diameter

The diameter of the wheel as indicated on the tire.

**Note:** A thick flange, on some aluminum wheels, can effect the measured diameter. For example, a 16-inch rim can have a measured diameter of 15.5-inches.

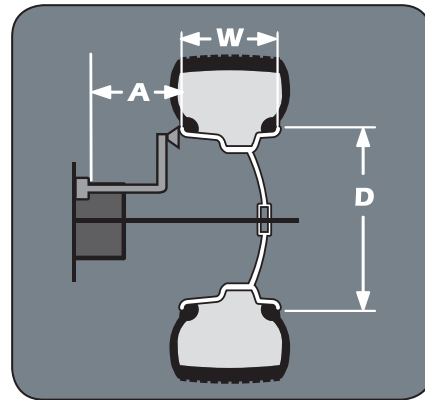

Figure 20 - W, D, and A Tire Dimensions

#### A2 = Offset

The distance measured from the balancer ("0" on offset arm) to outer plane of the rim (outer weight location). Used only for adhesive weight location.

#### D2 = Diameter

The diameter as measured at the A2 weight location. Used only for adhesive weight location.

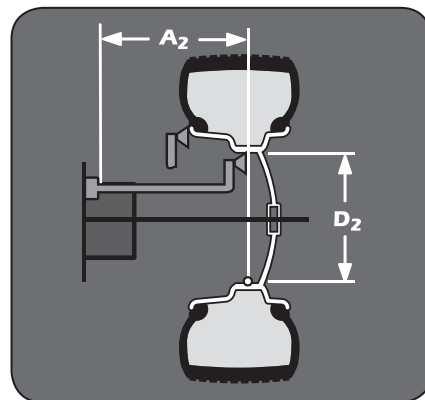

Figure 21 - A2 and D2 Tire Dimensions



## Basic Wheel Data Entry

**1.** Direct Select™ an Inboard weight location (Clip 1, or T1 Tape) and an Outboard weight location (T2 Tape, T3 Tape or Clip 2).

**2.** Position offset arm at clip weight location; wait for BEEP (A & D enters automatically).

**If the T2 Tape location is selected**, then move the offset arm from the clip weight location to the inner area of the wheel; up against the rim at the outboard weight placement location; wait for BEEP (A2 & D2 enters automatically).

**3.** Return offset arm to the home position.

**4.** Lower balancer hood to enter the W measurement automatically using the hood sonar (width sensor) and spin wheel.

## Entering Wheel Dimensions Manually

Information entered into the balancer software for A, W, and D can be changed anytime during a balancing procedure by entering the measurements manually. The balancer will recalculate weights and positions based on the new measurements. Select the DIM On Icon to access wheel dimension keypad, see page 11.

### Wheel Offset - A

**1.** Press the A (wheel offset) icon.

**2.** Position offset arm at weight location on wheel and read the number on the offset arm gauge, at the cabinet (this is the correct offset A DIM).

**3.** Using the keypad, enter the A measurement value including a decimal.

### Wheel Diameter - D

**1.** Press the D (wheel diameter) icon.

**2.** Inspect mounted tire sidewall to determine the exact diameter this is printed on the tire.

**3.** Using the keypad, enter the D measurement value including a decimal to match the tire sidewall size.

### Wheel Width - W

**1.** Press the W (wheel width) icon.

**2.** Use the plastic calipers provided with the wheel balancer to measure the wheel width.



Figure 22 - Caliper Placement On Wheel

**3.** Using the keypad, enter the W measurement value including a decimal to match measured caliper width of mounted rim.

## Balancing A Wheel

A variety of wheel configurations can be balanced using this wheel balancer. Read through this section, it will help in determining which balancing mode and options are best suited for certain wheel assemblies.

**Remember:** As with any balancing procedure, first remove any weights attached to the wheel, inspect the tire and wheel, and use the most appropriate balancer mounting method before beginning.

### Dynamic Balancing

Choose a dynamic balance to balance a wheel using two planes for correction. Select the weight option that best fits the available weight locations on the rim.

**Clip-on Weights** - The standard default; used for most passenger tire/wheel assemblies using the most common location for corrective weights. Clip-on weights are placed on the inner (inboard) and outer (outboard) rim flanges.

**ALUS (Aluminum Wheels)** - To balance aluminium wheels you usually use a self-adhesive weight location that is positioned differently from the clip-on weight position(s) used in standard balancing. Be sure to use the appropriate wheel data entry method since the balancer calculates out of balance values based on the wheel dimension measurements (DIM) entered for the tire/wheel assembly.

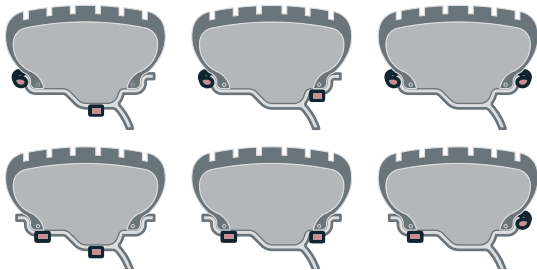

Figure 23 - Dynamic Balance Weight Locations

**Note:** When the machine is switched on, a standard dynamic balance using clip-on weight locations is the default setting.

### Static Balancing

Choose a static balance to balance a wheel using one plane for correction. Place the single corrective weight at top-dead-center (12 o'clock) on either flange, at the center of the rim channel, placed inward either side, or split on either sides.

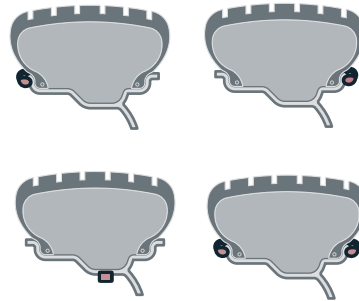

Figure 24 - Static Balance Weight Locations

**Note:** When in static mode, you only need to input the DIAMETER wheel measurement.

**Important:** If you decide to use the rim channel for corrective weight placement, remember you may need to adjust the DIAMETER measurement input. Typically you would make it 2 or 3 inches less than the actual tire/wheel diameter.



## Corrective Weight Placement

After the wheel spins and out of balances are measured and displayed, the corrective weight amount appears on the weight display dials for Inboard and Outboard weight locations. Bars appear on either side of the wheel cross-section graphic to aid in positioning the wheel for corrective weight at the application point.

After a measurement cycle, rotate wheel until the center weight position bar blinks, indicating the correct weight placement position is at top-dead-center. If the out-of-balance is less than the chosen threshold value, 000 appears instead of an out-of-balance value to indicate that, on that particular side, the wheel is in tolerance.

## Behind Spoke Mode

"Splitting" the T2 Tape corrective weight amount is used to hide the adhesive weight behind two rim spokes.

- 1.** When the unbalance is displayed, rotate wheel until Inboard center bar blinks. Attach Inboard corrective weight at top-dead-center.
- 2.** Press NEXT to rotate wheel until Outboard center bar blinks.
- 3.** Select the Behind Spoke icon to begin the behind spoke animation sequence. A SPOKE 1 icon will display on the dashboard.
- 4.** Rotate wheel toward front until the first spoke is at the laser dot; press SPOKE 1. Now a SPOKE 2 icon will display on the dashboard.
- 5.** Rotate wheel toward rear until the second spoke is at the laser dot; press SPOKE 2. Now at the spoke 2 location, the laser dot stops blinking.



Figure 25 - Spoke 1 and Spoke 2 Locations On Either Side Of Original Outboard Weight Location

- 6.** Attach the spoke 2 Outboard corrective weight at the laser dot behind spoke 2.
- 7.** Press NEXT to rotate wheel to spoke 1 location.
- 8.** Attach the spoke 1 Outboard corrective weight at laser dot behind spoke 1; then press NEXT.
- 9.** Press SPIN to check tire/wheel balance.

## ProBalance™ Technology

Any excessive residual unbalance is detected when using ProBalance Technology mode, see Balance Mode Icons, page 11. When activated, an enabled icon will display on the dashboard (figure 26).



Figure 26 - ProBalance Technology Enabled Icon

**1.** After correcting for dynamic unbalance, and excessive residual unbalance is detected over tolerance, then a PRESS TO CORRECT icon button will display on the dashboard (figure 27). Press the button.



Figure 27 - PRESS TO CORRECT Icon Button

**2.** The balancer stops and automatically positions the wheel at the ProBalance correction location. Now attach the specified corrective weight amount (figure 28) at the 12 o'clock position in the center of the rim channel (as displayed in graphic on wheel balancer).



Figure 28 - ProBalance Corrective Weight Amount

**3.** Respin tire/wheel to check balance.



Figure 29 - ProBalance Technology Successful Button

## Calibration

### Machine Calibration

1. Press SETTINGS icon and then select MACHINE CALIBRATION.
2. Press continue.
3. Enter the D dimension (include decimal point, example: 16.0 for a 16-inch wheel). Press ENTER.
4. Lower the hood and press SPIN.
5. After spin, raise the hood. Attach 4-ounce calibration weight to the outside flange at top-dead-center.



Figure 1 - Calibration Weight On Outside Flange At Top-Dead-Center

6. Lower the hood and press SPIN

**Important:** It is critical that the inner weight be placed accurately to achieve proper calibration. If the calibration weight is not moved from the outside flange directly across to the inside flange, an inner weight placement error will occur. To correct, follow the balancer instructions.

7. After spin, raise the hood. Move the 4-ounce calibration weight directly across and attach it on the inside flange at top-dead-center.



Figure 2 - Calibration Weight Moved (Directly Across) To Inside Flange

8. Lower the hood and press SPIN.

**Note:** If desired, rotate laser dot toward inner flange.

9. After spin, raise the hood. Rotate wheel to line up/center of 4-ounce calibration weight with laser dot. Hold position while pressing NEXT.

10. Press NEXT; then press EXIT.

11. Bring the tip edge of the arm precisely to the outer edge of the faceplate and hold it there (through step 12) while pressing the NEXT. (If necessary to reach the faceplate accurately, loosen the calibration wheel temporarily.)

12. With arm still at the edge of the faceplate, enter the A dimension (include decimal point) read off the arm gauge; see figure 3. Press ENTER.

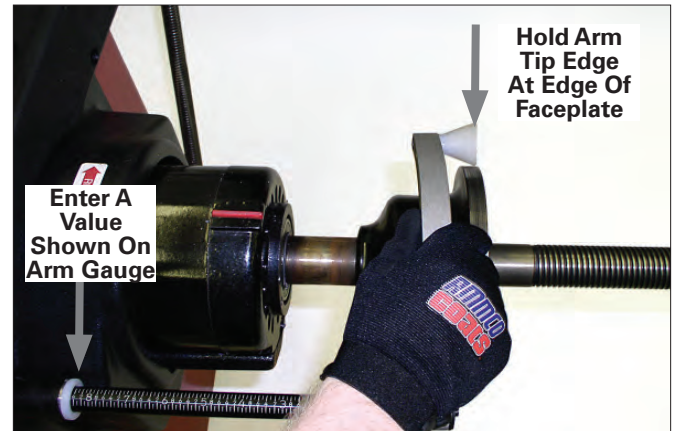

Figure 3 - While Holding Arm at Faceplate Edge, Enter A

13. Move arm to its home position and press NEXT.

14. Move arm to clip-on weight location on rim flange and hold it there (through step 16). Wait for voltage reading to stabilize, then press NEXT.

15. With arm still at clip-on weight location, enter the D dimension (16.0 for a 16-inch wheel) that is the diameter of the tire. Press EXIT.

16. While still holding the arm at the wheel's clip-on weight location, enter the A dimension (include decimal point) read off the arm gauge. Press ENTER

17. Return the arm to home position; calibration is complete. Press EXIT. Press STOP & EXIT to go back to the main screen.

## Maintenance Instructions



**Use common sense, this is an electrical device. Exposing the balancer to water, either by hose or bucket, or by exposure to rain or snow, may cause risk of shock or electrocution to operator or bystanders. Place, store, and operate the balancer only in a dry, sheltered location.**



**Do not hose down with water or bucket wash the balancer. Extensive damage to the balancer will result. Sensitive electronic components, wiring harnesses, and other devices housed in the balancer are not intended to be exposed to water.**

The balancer requires only minor maintenance to keep the unit operating properly.

**1.** Keep the touchscreen clean and clear. Use the screen wipes (part # 85609548) included with your Vero Series™ wheel balancer to clean the unit's touchscreen. Use of these or similar screen wipes, or a clean soft damp cloth are the only safe and acceptable methods to clean the unit's touchscreen. Do not use cleaners or solvents which leave oily or filmy residues behind that will void the touchscreen's factory warranty.

**2.** Keep the adapters, cones, faceplate, threaded shaft, pressure cup, and hub nut clean. Grease and dirt buildup will cause inaccurate balancing and premature wear. Clean these items at least once a day with a vaporizing solvent.

**3.** Clean weight tray and any accessory studs, pegs, or storage shelves with a mild detergent. Weights stored in a dirty tray may pick up grease and dirt which may keep them from securely attaching to the wheel.

**4.** Keep the area around and under the balancer clear. Remove any tools or other items that are leaning against the balancer. Remove any items that may cause the balancer to not sit level. Be particularly cautious of new or used wheel weights on the floor, as they may cause personal injury due to falls.

**5.** Use only COATS® accessories. Accessories from other manufacturers may not fit or function properly, and may damage the balancer.

## Diagnostic Procedures

### After Balance Vibration Problems

If vibration is still present after balancing the wheels and driving the vehicle on smooth pavement, remove the wheels and recheck the balance. If a wheel is out of balance the cause maybe:

- Wheel was not mounted/centered correctly on the balancer.
- A weight has come off the wheel (possibly the wrong clip style). Remove the other weights from the wheel and rebalance.
- Foreign material inside the tire. Remove the tire from the wheel, remove the foreign material, and remount. Remove wheel weights and rebalance the wheel.
- Stones or other foreign objects caught in the tire tread or rim. Remove the objects. Check and rebalance if needed.

If the balancer still indicates the wheels are balanced to within 0.05 ounces (1.42 grams) on both inner and outer displays, the problem is not in the balance of the wheels. Check the following possible sources of vibration:

- Tire pressure. Bring all tires up to the recommended PSI.
- Radial or lateral runout in the tire or wheel. Replace the damaged part.
- Out of balance in wheel covers or trim rings. Remove the wheel covers or trim rings and test drive. If the vibration is gone, remove the shaft and use an appropriate adapter to mount the wheel to the balancer. Balance the wheel with the wheel cover or trim ring attached to the wheel.
- Incorrectly mounted tire and wheel. Remount correctly.
- Damaged wheel bolt holes. Replace wheel.
- Worn universal joints. Replace as required.
- Drive shaft out of balance or damaged. Balance, repair, or replace.
- Out of balance in brake rotor(s) or drum(s).
- Suspension out of alignment. Align the vehicle and replace any damaged or worn parts.

## Troubleshooting

A COATS® Service Technician may ask for information to help diagnose service concerns (please contact COATS directly at 1-800-688-9240 for the Certified Service Partner nearest you). Conveying this information to your service technician prior to servicing can help to expedite service to your equipment. Although much of the diagnostic information aids your COATS Service Technician, several remedies for balancer misfunctions are available to the operator.

**Error Messages** - One of the following error messages, shown in the display windows, may appear indicating a problem with the balancer.

**Note:** Always, after receiving an error message, repeat the procedure to see if the error is eliminated.

<b>Error</b>	<b>Description</b>
<b>E1</b>	Spin up is too slow - Verify power supply to balancer and motor connection
<b>E2</b>	Spin up time too long - Check Wheel DIA and power supply - press STOP - EXIT
<b>E3</b>	No rotation signal - Check motor & encoder function & wiring -press STOP - EXIT
<b>E4</b>	Wheel rotation direction is reversed - Disconnect power and correct wiring
<b>E5</b>	Stop time too long - Verify power supply and motor connection - press STOP - EXIT
<b>E6</b>	Encoder is not connected or has failed - Disconnect power supply and repair
<b>E9</b>	Wheel coast speed is too slow
<b>E11</b>	User cancelled the operation
<b>E20</b>	Arm scale is out of range
<b>E24</b>	Lower hood to spin
<b>E25</b>	Loose hub nut. Tighten hub nut and respin
<b>E26</b>	CAL ERROR
<b>Err Hod</b>	Hood switch is not closed when machine cycle is started - Lower hood to spin - Verify hood switch
<b>Err Hub</b>	No load condition detected - Verify wheel mounted properly on the shaft - Check repeatability
<b>Err Ad</b>	No dimension input
<b>Inverter Error</b>	Inverter Fault-Please Wait ...

<b>Error</b>	<b>Description</b>
<b>100, N01, CAL</b>	Exceeded 5 degree range between placement of calibration weight from outside flange to inside flange.
<b>100, N02, CAL</b>	Calibration wheel is more than 1-ounce out of balance. Calibration is rejected.
<b>100, N03, CAL</b>	Calibration wheel is more than 0.25-ounce but less than 1-ounce out of balance. Calibration is stored, but with warning.

**Inverter Error** - An inverter error occurs when one of several fault conditions is detected by the inverter; such as, low line voltage, motor over temperature, motor overload or motor drive over temperature. The balancer will not respond to inputs until the fault condition is corrected. The balancer will clear this error as soon as possible and indicate that with the following message: Inverter Fault Cleared. Press Any Icon

**Overload Protection** - The balancer's motor is overload protected per UL requirements. After 4 to 5 minutes the machine automatically resets itself; activating the fan motor. If this happens, notify your Certified Service Partner immediately.

**Important:** Allow the fan to cool the motor for at least 30 minutes before using the balancer so the overload protection is not tripped again.



## Glossary

**ALUS** -Alloy wheel mode that typically requires the use of one or two adhesive weights for correction.

**Balancer Flange** – Disk that mates with the disk of the wheel mounted to the balancer. The flange also serves to keep the wheel perfectly perpendicular to its axis of rotation.

**Balancing Cycle** – Sequence of operations performed by the user and the machine, beginning from the start of the wheel spin to the time that the wheel is braked to a standstill after the out of balance signals are acquired and the relative values calculated.

**Centering** – Procedure for positioning the wheel on the spindle shaft with the aim of ensuring that the rotational axis of the wheel is aligned with the center of the shaft.

**Centering Flange (accessory)** – Device serving to support and center the wheel. Also keeps the wheel perfectly perpendicular to its axis of rotation. The centering flange is mounted to the balancer shaft by means of its center hole.

**Cone** – Conical components with center hole. When inserted on the spin shaft, serves to center wheels with centre holes whose diameter is between maximum and minimum values.

**Dynamic Balancing** – Operation in which out of balance is corrected by the application of two weights, one on each side of the wheel.

**Self-calibration** – A procedure whereby suitable correction coefficients are calculated by starting from known operating conditions. Self-calibration improves the measurement precision of the machine by correcting, within limits, calculation errors that may arise due to alteration of the machine's characteristic over the course of time.

**Spin** – Procedure starting from the action that causes the wheel to rotate and the successive free rotation of the wheel.

**Hubnut** – Device for clamping the wheel to the balancer. The hubnut features elements for engaging to the threaded hub and lateral pins that are used to tighten it.

**Static Balancing** – In static balancing only the static component of out of balance is corrected. This is achieved by fitting a single weight, usually at the center of the rim channel. The accuracy of this system increases as the width of the wheel decreases.

**Threaded Hub** – Threaded part of the shaft that is engaged with the hubnut to clamp the wheel. This component is supplied disassembled from the machine.

**Out of balance** – Non-uniform distribution of the wheel mass that results in the generation of centrifugal force during rotation.





