

COATS®

Truck Wheel Balancer

Model 6200HS

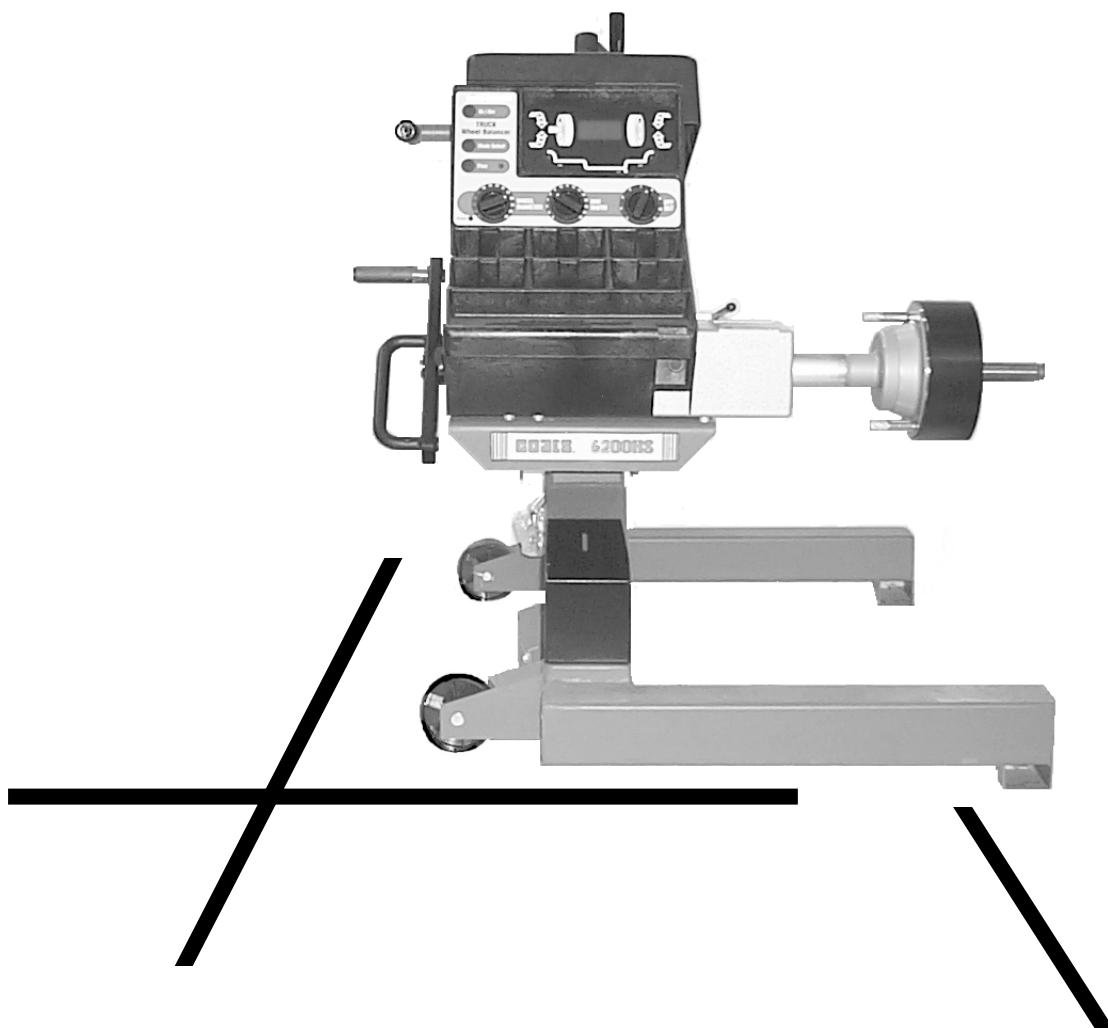

OPERATION GUIDE

FORM Z6200HS

CONTENTS

- Safety Cautions and Warnings ii
- Installation iii
 - Unpacking iii
 - Assembly iii
 - Setup iv
 - Weight Increment Selection Mode iv
 - 12V Battery Operation iv
- Introduction 1
- Features 2
- Accessories 3
 - Standard Adaptors 3
- Functional Description 4
 - Balancer Display 5
 - Input Panel 6
 - Offset Scale 7
 - Callipers 8
 - Accessory Storage 8
 - Crank Handle 8
 - Weight Storage 8
- Balancing Operation 9
 - Operating Procedure 9
 - Balancing Errors 12
- Weight Modes 13
 - Normal (clip-on) 13
 - Alu/Mag 13
 - Static 14
 - Weight Location Dimensions 14
- Special Applications 15
- Wheel Mounting Methods 17
 - Wheel Mounting Methods (Truck) 17
 - Wheel Mounting Methods (Automobile) 19
- Power Sources 23
- Automatic Calibration 24
 - Calibration Procedure 24
 - Calibration Errors 25
- Service and Maintenance 26
 - Operational Check 26
- Troubleshooting Guide 28
- Technical Specifications 30

SAFETY CAUTIONS AND WARNINGS

1. Read the Operators Manual before operating the balancer for the first time. Follow all instructions and warnings marked on the product.
2. The balancer operates from a) 110Vac, 60 Hz wall outlet with the supplied 8.5Vac power converter b) 12Vdc supply. Do not use any other electrical sources. Use only an EARTHED electrical power source. Use only a correctly rated replacement fuse.
3. Arrange the power cord so that it will not be tripped over or pulled, and keep it clear of moving parts. If an extension cord is used, ensure its current rating equals that of the power cord supplied. Immediately replace a damaged power cord.
4. Ensure the balancer rests on all three feet on a clean, level floor with no debris under the base.
5. Do not operate the balancer: a) near fumes or exposed flammable liquids; b) on wet surfaces. Do not expose the balancer to rain.
6. Adopt the correct lifting procedures when lifting any object. Weights in excess of 100lb (45kg) should not be lifted unaided.
7. NEVER remove a cover or access panel on the balancer without first disconnecting the balancer from the electrical power source.
8. Only authorized and trained operators should use the machine.
9. Wear approved eye protection when removing or attaching weights. Keep hair, clothing and all parts of the body clear of balancer moving parts.
10. Remove all stones, old weights, and other debris from the wheel before balancing.
11. Centre and tighten the wheel on the shaft before spinning the wheel.
12. Check that all wheel weights are properly applied and secured.
13. The balancer will return to the normal power-up state if the power is interrupted.
14. When the balancer is not in use, disconnect the power cord and use the available pegs and trays for storage of accessories.

INSTALLATION

Your Model 6200HS Truck Balancer and accessories will be delivered in a single carton mounted on a pallet.

Unpacking

- A. Unpack the balancer and all accessories.
- B. Check the contents list below and confirm that all parts are present. Check also for the standard wheel mounting accessories and any optional accessories you may have ordered.

Qty	Item
1	Balancer assembly.
1	Stub shaft and bolt.
1	Plug-in power converter.
1	Light truck cone.
1	Medium truck cone.
1	Large truck cone.
1	Rim width Callipers.
1	Spacer Ring.
1	Hub nut assembly.
1	Operators manual.

Assembly

*Tools required : 10mm and 1/2" spanner
 Philips screwdriver
 9/16 thin wall socket*

1. Place the balancer on a firm solid floor.
2. Fix the stub shaft to the spindle, by inserting the bolt and tightening to a torque of 30Nm (110lbsin-130lbsin) using a 9/16 thin wall socket.
3. Verify the correct voltage is shown on the product serial label and the power converter supplied. Plug the power converter into the mains outlet. Connect the power converter cord to the input connector at the rear of the balancer measuring head. The balancer beeps and is switched on.

Your balancer is now ready for use!

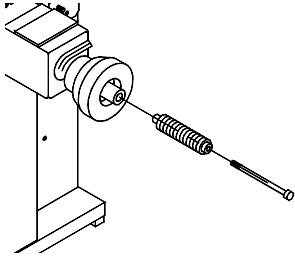

Setup

The balancer is programmed before leaving the factory to display weight imbalance in grams. To change this setting to ounce units, press oz/gram button, a decimal point appears in the Display Window (0.00). Repeating these steps will change the units back to grams (000).

Weight Increment Selection Mode

Machine is shipped in 25g (1oz) Increments to switch to 50g (2oz) Increments, follow this procedure.

1. With the machine powered off press and hold the mode button.
2. Turn the power back on while still holding down the mode button, wait about 7 seconds for the machine to beep, machine is now in 50g (2oz) increments.

Maintenance

1. Clean mounting accessories, mounting surface, and spindle of balancer regularly. Grease and oil accumulate dirt which can cause incorrect balance results, and also act as a grinding compound resulting in premature wear.
2. A light coating of grease should be maintained on the sliding contact faces of the lifting section.
3. Remove wheel weights and rubbish from under the balancer.
4. Do not lean any tyres, rims, tools or other parts against the balancer.
5. Clean the Control Panel and Display Window with window cleaner.

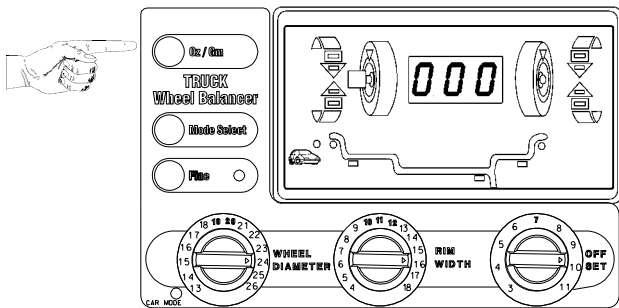

INTRODUCTION

The Coats Truck Balancer combines advanced, high-performance technology, robustness, reliability and simplicity of operation.

The features of the Coats Truck Balancer cater for all wheel service facilities. It is designed for use under a wide range of conditions, and will maintain perfect operation under the most demanding usage.

Low-speed rotation of the wheel by hand-spinning ensures that the Coats Truck Balancer is one of the safest machines available.

The Coats Truck Balancer offers complete portability and features an easy-to-use Display and Input Panel, ensuring quick and intuitive operation. Operator time and effort are reduced to a minimum, while maintaining wheel balancing accuracy and repeatability.

Take a few minutes to study this manual and become acquainted with the features and capabilities of your new Coats Truck Balancer before operating the balancer for the first time.

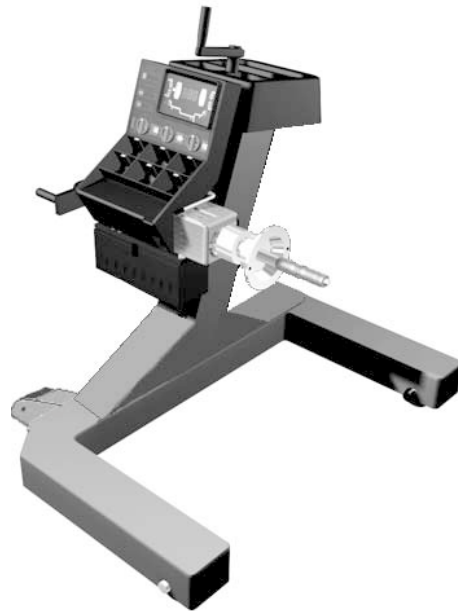

FEATURES

The COATS computerized wheel balancer combines state-of-the-art electronic accuracy with ease of use and simplicity of design. Your COATS product will give you years of reliable operation and wheel balancing profits.

The Balancer represent today's most advanced concepts in wheel balancing with these high-precision features:

- *Safe, accurate, low-speed operation -*

Balance Truck wheels to 5 gram accuracy (Automobile wheels to 2 gram) at an operating speed of only 70 rpm.

- *Fast and simple -*

With a single spin cycle of between 10 and 20 seconds (depending on wheel size) and a large display that shows the exact weight requirement and location, your balancer will promote productivity and profits.

- *Electronic simplicity -*

All major components can be replaced in the field, and the automatic self calibration program allows the balancer to calibrate itself with little or no downtime.

- *Six balancing modes-*

Normal for standard clip-on weights on the inner and outer rim flanges.

Static (single plane) for some specialty wheels.

Four Custom modes for combinations of clip-on and stick-on weights, including hidden-weight balancing.

- *Lightweight and Portable -*

The patented hand operated wheel lifting mechanism (no pneumatics) and built in battery, allow the balancer to be taken to the Truck. The battery automatically recharges when the unit is connected to the mains supply.

- *Economical -*

The balancer conserves energy by powering down when not in use. Mounting a wheel automatically powers up the unit again.

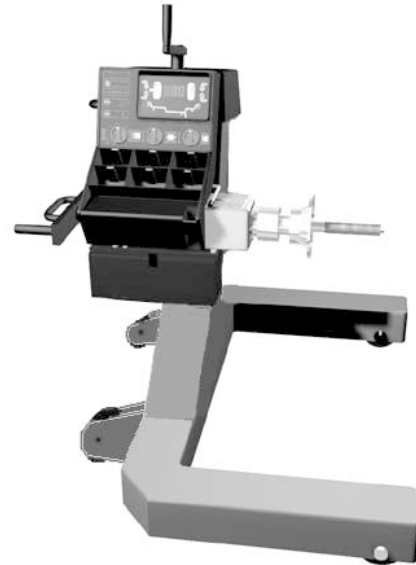

ACCESSORIES

Standard Adaptors

Standard Wing Nut (P/N 112100)

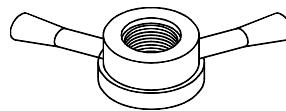

40 x 4 Shaft (P/N 112095)

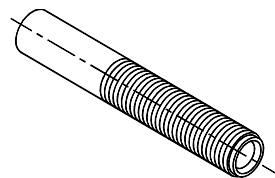

Backing Disc (P/N 112096)

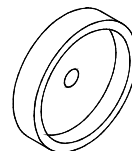

Cone (95mm-133mm) 3.8"-5.32" (P/N 112097)

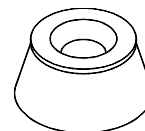

Cone (122mm-175mm) 4.88"-7.0" (P/N 112098)

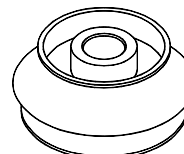

Cone (198mm-225mm) 7.92"-9.0" (P/N 112099)

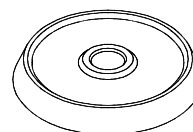

FUNCTIONAL DESCRIPTION

The following diagram shows a view from the front of the complete assembled Truck Wheel Balancer.

1. Input Panel
2. Display Panel
3. Weights Storage
4. Offset Scale
5. Stub Shaft
6. Flange
7. Hammer Holster
8. Accessory Storage
9. Crank Handle
10. Lift Handle

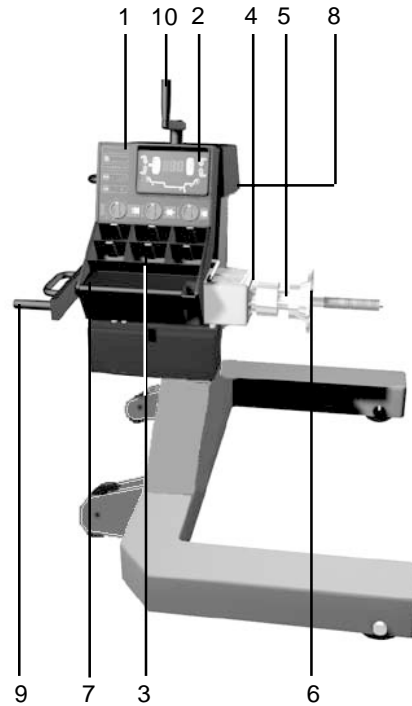

Balancer Display

The display combines solid-state electronics and graphical design to provide powerful visual presentation and durability.

The display indicates the amount and position of weights, wheel dimensions, operating modes and error conditions.

1. Numeric Display

Displays weights in grams or ounces after a spin cycle, when the wheel is rotated to the inner or outer Top-Dead-Center position. Displays wheel dimensions (diameter, width, offset) in inches or millimeters during wheel data entry. Displays 'EEE' to report an error.

2. Decimal Point

Illuminated constantly when ounces are selected as weight units.

3. Weight Position Indicators

Illuminated sequentially as the wheel is rotated and the correct position for weight placement is approached. This applies to both inner (3a) and outer (3b) weight positions.

4. Top-Dead-Center Indicators

Illuminated when the correct position for attaching the weight at Top-Dead-Center (TDC) is reached. There are separate indicators for the inner (4a) and outer (4b) TDC positions.

5. Rim Profile

Graphical rim profile to illustrate the Weight Mode in operation.

6. Weight Mode Indicators

Illuminated Clip-On Weight (green, circular) and Stick-On Weight (yellow, rectangular) indicators to correspond to the Weight Mode selected.

7. Car Indicator

When the rim diameter is set at 17" or less the Car Indicator will light. This allows wheels to be Fine balanced to an accuracy of 2 grams (0.10 ounce). Refer also to the *Weight Location Modes* and *Automatic Calibration* sections of this manual for further details.

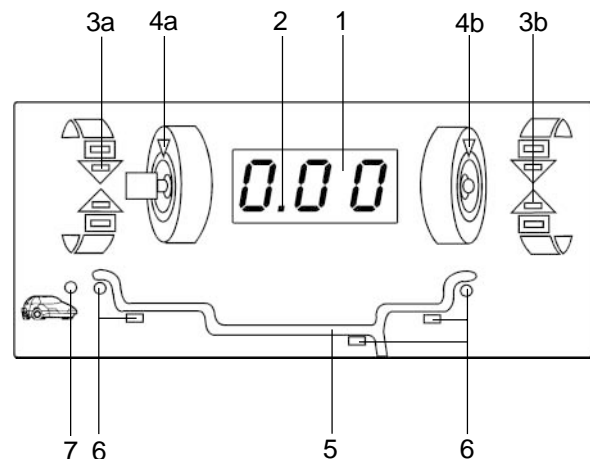

Input Panel

The input panel combines controls and indicators, positioned for convenience, with graphical symbols clearly defining each function.

The input panel is used to select and indicate specific operating states and to enter data for the wheel to be balanced and the weights to be used.

1. Ounce/Grams Button

This button is used to select Ounce/Grams and Calibration. To change from ounces to grams or vice-versa, hold the Ounce/Grams button while pressing the "Fine" mode button.

2. Mode Select Button and Weight Location LED Indicators.

The Mode Select Button works in conjunction with the Weight Location LED Indicators on the Display, to select the correct balance weight location. Weight requirements are automatically recalculated when the Mode is changed.

For easy and accurate custom mode operation, do the balancing operation in the NORMAL (clip-on) Mode. Then press the Mode Select Button for the desired custom weight location. The balancer will automatically recalculate the amount of weight required for the selected weight location.

3. Fine Button.

Switches the balancer between Standard and Fine resolution. The Fine LED Indicator lights when the balancer is in Fine resolution.

4. Rim Diameter Knob.

Turn the Rim Diameter Knob to set rim diameter as shown on the tire sidewall. Read the selection in the Display Window.

5. MM Indicator.

Turning the Rim Diameter Knob fully counter clockwise allows the rim diameter to be set in millimeters. When the MM LED is lit the Display Window will show the diameter in millimeters.

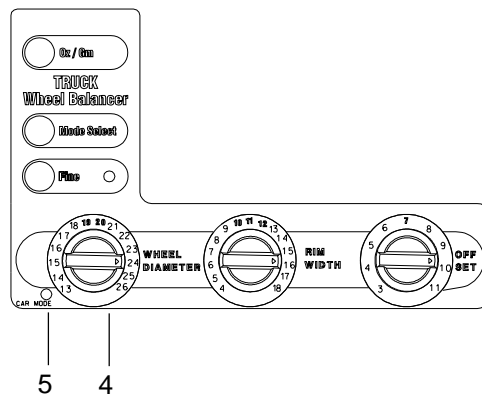
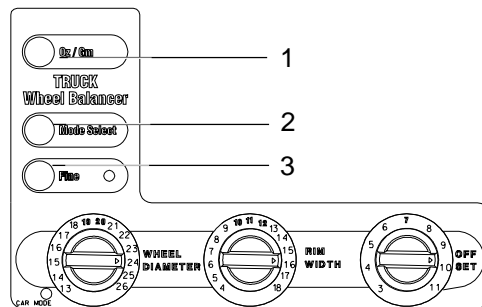

6. Rim Width Knob.

Turn the Rim Width Knob to set rim width as measured with the callipers. Read the selection in the Display Window.

7. Offset Knob.

Turn the Offset Knob to set rim offset, or distance. Read the selection in the Display Window.

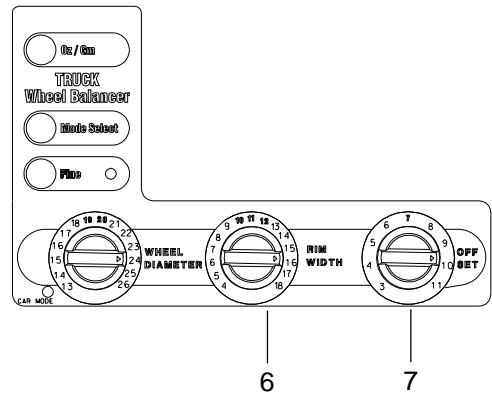

Offset Scale

Offset, or rim distance, is a measurement of where the wheel is mounted relative to the body of the balancer. The offset scale measures this distance. The offset scale is located at the top rear of the head. The offset value is read at the point where the scale arm enters into the housing. This value is input with the Rim Offset dial on the input panel. The scale is spring-loaded and will return to its resting position when released.

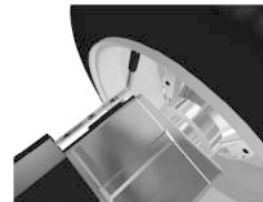

Calipers

The calipers are used to measure the width of the rim of the wheel being balanced. The width is then programmed with the Rim Width dial on the input panel.



Accessory Storage (1)

The accessories can be stored on the protective shelving at the back of the machine or on the moulded top tray.

Crank Handle (2)

The crank handle is fixed to the balancer and is used to spin wheels mounted on the measuring head, in cases where it is impossible to spin the wheel using the standard hub nut (typically in the case of closed-center wheels).

Weights Storage (3)

The moulded tray on the front and top of the balancer contains compartments for weights and storage areas for weight pliers and accessories.

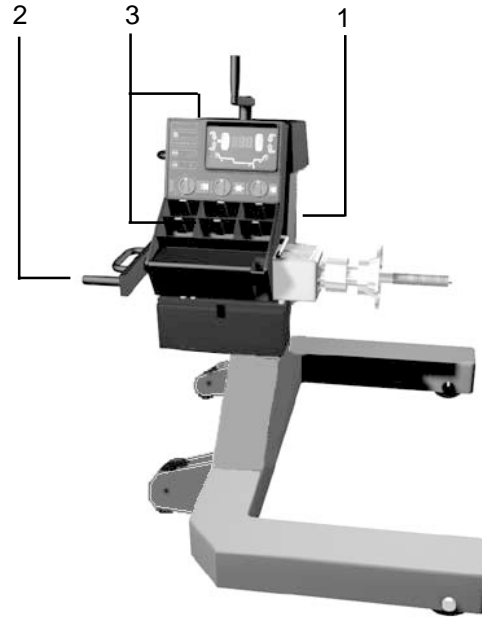

BALANCING OPERATION

Operation of your Coats Truck Balancer is based on LED indicators on the control panel, two soft-touch buttons and three control knobs allow you to enter all information needed for precision balancing. The display indicates dimensions as they are entered.

Operating Procedure

The following Procedure covers the main steps for fast, accurate wheel balancing with your Coats Truck Balancer. Later sections of this manual contain detailed information on weight location modes and wheel mounting methods for your balancer.

1. Mount the wheel.

Most original equipment and aftermarket wheels can be mounted using some combination of the standard mounting adapters. Refer to the *Wheel Mounting Methods* section of this manual for more detailed instructions.

2. Select the required Weight Locations.

Depress the Mode Select Button repeatedly until the Weight Location Indicators display the chosen locations.

3. Set the Rim Diameter Knob to the Diameter shown on the tire sidewall.

Note: For tube type wheels with removable rim flanges the diameter should be set to greater than the nominal tire diameter. To display the diameter in millimeters, turn the Diameter Knob fully counter clockwise. The MM Indicator will light and the diameter will be shown in millimeters in the Display Window. When Diameter Knob is set at 17"(430mm) or below the balancer automatically lights the Car Indicator.

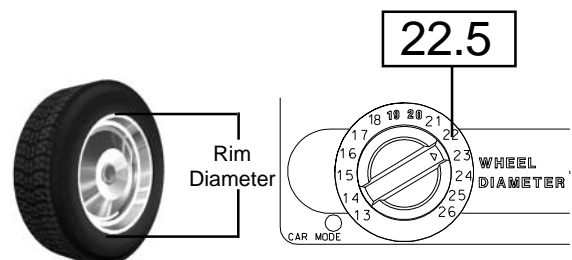
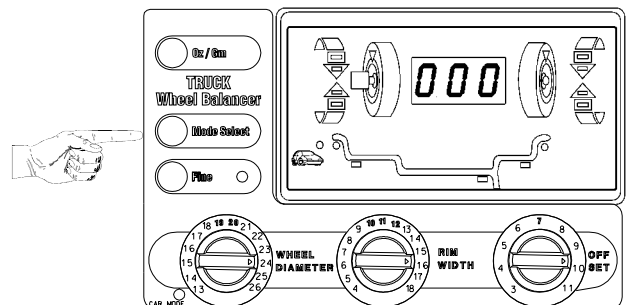

4. Set the Rim Width Knob as measured with the Calliper.

Note: If the tire is too wide to accept the callipers, then measure over the thread width.

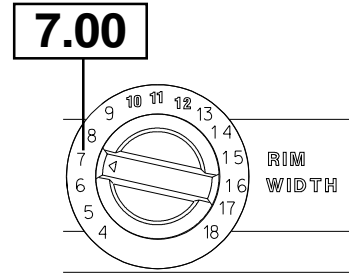

5. Set the Rim Offset Knob as follows.

- a. Pull the rim offset scale arm out and position the tip against the rim flange surface (regardless of where the inner weight will be placed).
- b. Read the rim distance value off the scale arm at the point where it enters into the housing.
- c. Set the Offset Knob to the rim distance value.

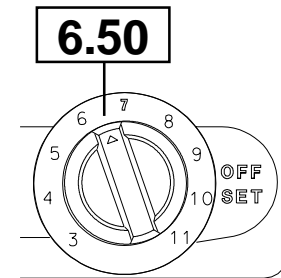
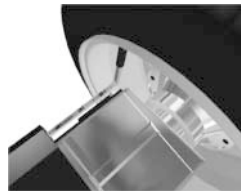

6. Spin the wheel.

- a. Raise wheel using lift crank handle at top of balancer. Wheel should clear the floor by approximately 1/2"(13mm). Greater clearance is unnecessary and would require additional cranking to lower and stop the wheel.
- b. Turn the spindle crank handle until a beep is heard. Release handle immediately. Do not interfere with the machine or wheel during the measuring cycle or wrong readings can occur. Normal balance speed is between 70 and 84 rpm. If spun too fast, the buzzer will sound continuously until the wheel slows to proper measurement speed. The balancer will function normally even when a wheel is spun too fast, however balancer cycle time will increase. A second buzzing sound will indicate that the measuring cycle is complete.
- c. Stop the wheel by using the lift crank handle to lower the wheel until it touches the ground. Car/ Light Truck Wheels can be stopped by using the weight hammer against the tire side-wall.



Note: *Do not use your hand to stop the wheel.*

7. Attach the Weight.

- a. Starting with either side of the wheel, rotate the wheel in the direction of the lit arrow until all 6 Arrow Indicators and the Top Dead-Center Indicator are lit. The correct balance weight will now be displayed.
- b. Securely apply the displayed weight at the top-dead-center location on the indicated side of the wheel.
- c. Repeat steps 7a and 7b for the other side of the wheel.

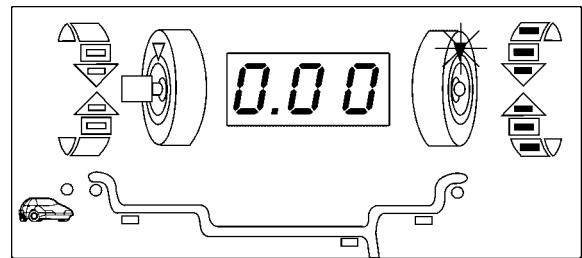

8. Do a Check Spin

Repeat the spin cycle (step 6). Zero weight readings should appear for both sides of the rim.

Optional: If desired wheels may also be Fine Balanced to 2 gram (Car/Light Truck) or 5 gram (Truck) accuracy. Press the Fine Button on the left side of the Control Panel. It is necessary to spin the wheel again when the Car LED is lit, as the balancer calculates the fine balancing requirements from the previous measurements, and the Display will show the weight requirements. When balancing Truck wheels, it is necessary to re-spin the wheel after switching to Fine. If a repeatable balance can not be achieved, there is a possibility of foreign material moving around inside of the tire causing a different imbalance every time. This material must first be removed before the wheel can be balanced.

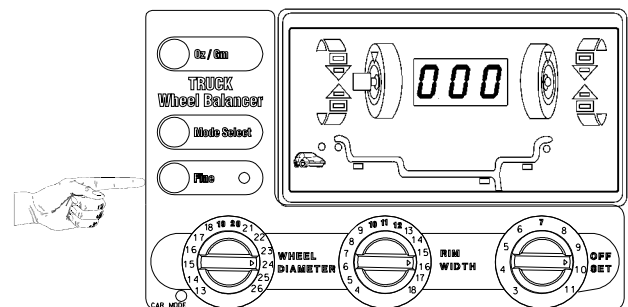

Balancing Errors.

The crank handle has a one-way clutch for operator safety, which also ensures that the wheel is spun in the correct direction. It is however possible to spin the wheel in the wrong direction (counter clockwise) when using the Hub Nut. If this error occurs it will be identified by an 'EEE' appearing in the Display Window.

If the wheel is intentionally (manually aborted) or accidentally (wheel touches floor or operator) slowed or stopped during the measuring cycle, 'EEE' will also appear in the Display Window.

Spinning the wheel in the proper direction up to balancing speed will remove this error and allow the balancer to function normally.

In some cases when a very light wheel (i.e. a 13" automobile wheel) is being balanced, 'EEE' may appear. Re-spinning at a higher speed will prevent this occurring and allow such wheels to be balanced.

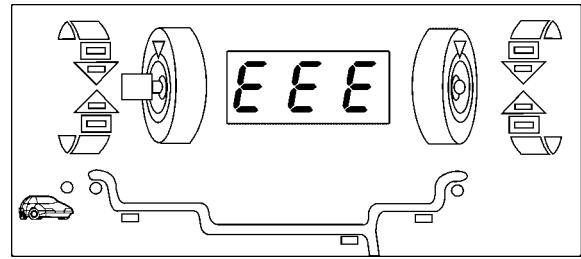

WEIGHT MODES

The COATS balancer features one Normal (clip-on) and four Custom (Alu/Mag) Modes for combinations of clip-on and stick-on weights. A static balancing mode is also included.

As the Mode Select Button on the control panel is pressed, the Weight Location LED Indicators on the Display Panel indicate the desired weight location. When placing the weights for any of the Alu/Mag modes, observe the location dimensions shown opposite. Note also that these dimensions differ for Car/Light Truck (diameter set below 17") and Truck wheels. The balancer is programmed for these dimensions, other placement locations will require different weights.

Normal: LED's 1 and 5 light to indicate standard clip-on weights on the inner and outer rim flanges.

Alu/Mag 1: LED's 1 and 4 light to indicate a standard clip-on weight on the inner flange and a stick-on weight on the outer bead seat of the rim.

Alu/Mag 2: LED's 2 and 4 light to indicate stick-on weights on the inner and outer bead seat areas of the rim.

Alu/Mag 3: For this hidden weight method, LED's 1 and 3 light to indicate a standard clip-on weight on the inner flange and a stick-on weight towards the center area of the rim.

Alu/Mag 4: For this hidden weight method, LED's 2 and 3 light to indicate a stick-on weight on the inner bead seat area and a stick-on weight towards the center area of the rim.

When using the Alu/Mag 3 or Alu/Mag 4 Modes, the inner and outer weights **MUST** be placed the correct distance apart longitudinally (dimension "D"). The balancer is programmed for this distance when using these Modes. If it is necessary to use weight placements not catered for in the section, refer to the *Special Applications* section of the manual.

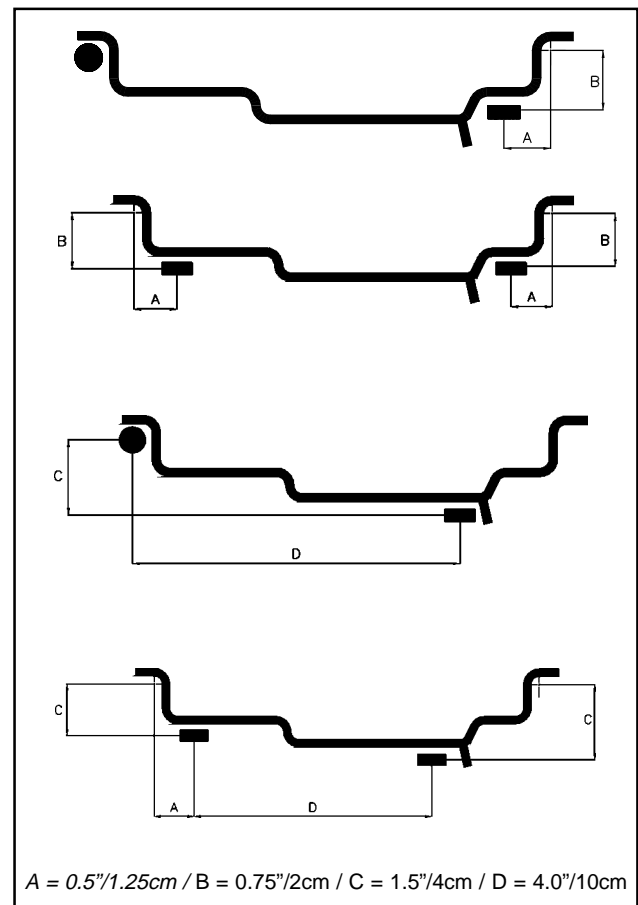
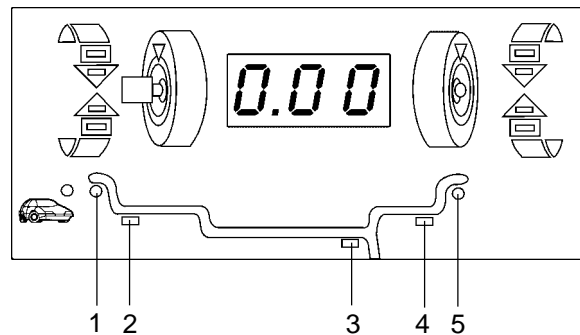

Weight Location Dimensions for Car / Light Truck

Static Balancing: For this method, only LED 3 lights to indicate a single clip-on or stick-on weight. The weight can be positioned on the inner or outer rim flange, or towards the center of the rim. If the imbalance is large, the amount of weight required can be divided equally between the inner and outer rim flanges.

For static balancing, the rim width and offset dimensions do not need to be entered into the balancer, simply enter the wheel diameter. After the measuring cycle, the inner arrow LED's and TDC indicators will light to show the required weight amount and position.

For simple and accurate balancing, the Normal mode can be used for all balancing measurements. After the balancing cycle, press the Mode Select Button repeatedly until the LED indicators light for the desired weight locations. The balancer will automatically recalculate the weight required for each mode.

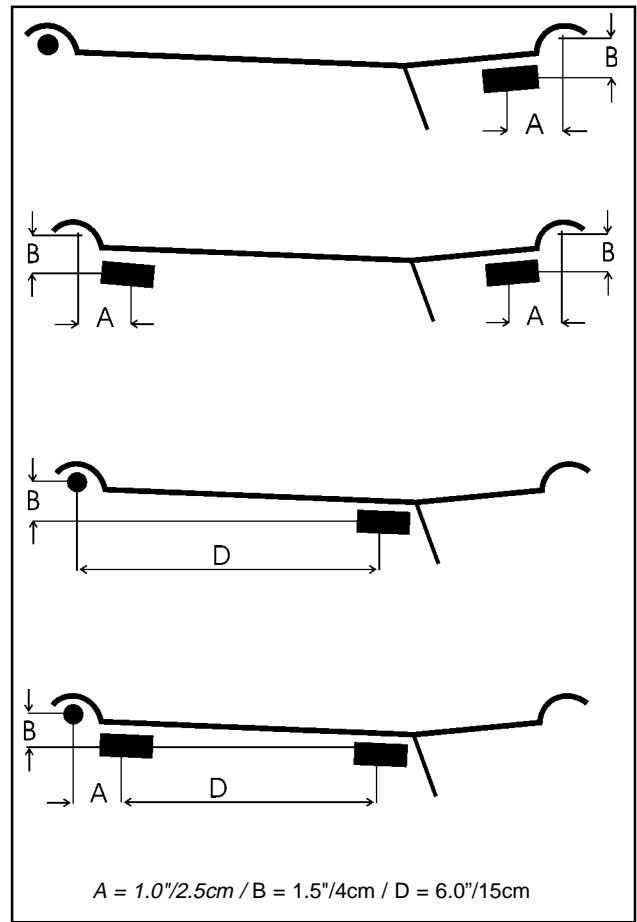

Weight Location Dimensions for Truck

SPECIAL APPLICATIONS

Occasionally it may be necessary to use weight locations which are different than those catered for in the standard Alu/Mag programs. This will usually only occur for hidden weight methods, where the distance between the weights of 10 cm (4") for car/light truck or 15 cm (6") for truck is not suitable. If you encounter any situation where special weight locations are required proceed as follows:

1. Select Normal (clip-on) Mode.

Press the Mode Select Button repeatedly until Weight Location LED Indicators 1 and 5 are lit.

2. Set the Rim Diameter Knob.

When using stick-on weights set the knob diameter to less than that indicated on the tire sidewall. Typically on a 14" rim the diameter would be set to 12.5" and a 22.5" rim to 19.5". For thicker rims the diameter may need to be set lower.

3. Set the Rim Width Knob.

Measure the distance between the two weight locations A and B. If weight B is a hidden weight use a tape measure or rule. If weight B is on the outer the calipers can be used. Set the Width Knob as measured.

4. Set the Rim Offset Knob.

Pull the rim offset scale out and position the tip at the point where the inner weight is to be located. Set the Rim Offset Knob to the distance measured.

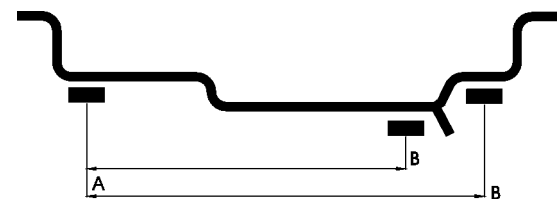
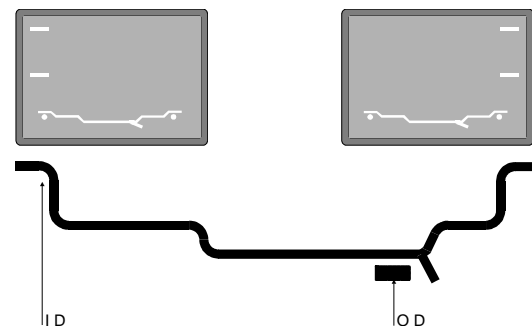

5. Spin the Wheel.

Complete normal balance routine.

6. Attach the Weight.

Starting with either weight location, rotate the wheel until the TDC position is found. Attach the weight as indicated in the Display Panel. **N.B.** If the weight is not attached at the correct locations (as measured), accurate balance results will not be achieved. Repeat this step for the other weight location.

7. Do a Check Spin.

Repeat the normal balance routine. Zero weight readings should appear for both weight locations.

WHEEL MOUNTING

Careful wheel mounting is essential, as the wheel is balanced relative to how it is mounted on the balancer. If the wheel is not well centered and sitting squarely against the balancer flange plate, accurate balance results will not be achieved.

Most stud-centered wheels have concentric center holes, which allow fast and easy cone mounting. Adapters should be used only in problem situations and on some aftermarket specialty wheels.

The Standard Accessories and Optional Accessories supplied with your COATS balancer allow the following wheels mounting methods.

Wheel Mounting Methods (Truck Wheels)

Cone Mounting

Hub piloted wheels must be cone mounted. Hub piloted wheels can be identified by the lack of stud hole countersinks.

Install the Spacer Ring / Distance Ring against the back flange of the balancer. The Ring is required for large and medium truck cones, and is optional for use with light truck cone.

Choose a cone that fits best when placed into the wheel center hole. With the tire on the ground, slide the balancer so that the spindle extends through the wheel center hole as shown. Mount the cone on the protruding spindle and slide into the wheel center hole. Raise or lower the spindle with the lift handle as needed for optimum alignment. Thread the Spindle Nut or Hub Nut, whichever is appropriate, onto the spindle and hand tighten. Raise the wheel slightly so that it clears the ground and securely tighten the Spindle or Hub Nut.



Combination / Bolt Plate Adapters

Stud piloted wheels must be mounted using the combination adapter or a bolt plate adapter. Stud piloted wheels can be identified as those with stud hole countersinks.

For the combination adapter, clean the balancer flange and attach the adapter flange plate. Select the relevant clamping plate (4 or 5 star), and position the studs on the correct P.C.D. With the tire on the ground, slide the balancer so that the spindle extends through the wheel center hole. Mount the clamping plate on the protruding spindle and slide into the wheel stud holes. Raise or lower the spindle with the lift handle as needed for optimum alignment. Thread the Spindle Nut onto the spindle and hand tighten. Raise the wheel slightly so that it clears the ground and securely tighten the Spindle Nut.

If using a bolt plate adapter, first install spacer ring (P/N 1489) to the balancer flange. Select the correct bolt plate, and facing outwards, slide onto the stub shaft, ensuring that the location pins engage in the relevant holes. Secure the adapter in place by tightening the spindle nut to approximately 50 Nm (184lbsin-203lbsin). With the tire on the ground, slide the balancer so that the spindle extends through the wheel center hole, and the studs align in the stud holes. This may require slight height adjustments using the lift handle. Hand tighten the wheel nuts until snug, then using a crisscross sequence tighten securely to a torque of approximately 50Nm (184lbsin-203lbsin).

WHEEL MOUNTING METHODS (AUTOMOBILE WHEELS)

Back Cone Mounting

Back cone mounting is the most common way to mount automobile wheels. Choose the cone that fits best when placed through the wheel center hole from the rear. Slide the cone spring and cone on the shaft. Place the wheel on the cone and be sure that the cone center the wheel when you tighten the handle.

The pressure drum should contact the wheel on a flat surface. Do not center the wheel with the pressure drum. Tighten the wheel firmly against the mounting flange. Hold the handle in place and rotate the wheel when tightening. Be sure that the wheel is firmly against the mounting flange and the handle threads engage at least three turns on the shaft.



Front Cone Mounting

Front cone mounting is required when using light truck wheels and is also an acceptable alternative for many automobile wheels. The wheel center hole must be true on the outside of the wheel to use the front cone mounting method.

Choose the cone that fits best when placed through the wheel center hole from the front. Slide the wheel on the balancer shaft without a back cone or spring on the shaft. Place a cone on the shaft, through the front of the wheel. Be sure the cone center the wheel and that the wheel is squarely against the mounting flange when you tighten the handle.



Back Cone Mounting without Pressure Drum

Ensure the handle does not contact the cone, or the wheel will not be centered and mounted securely. Attach the spacer ring to the hub nut if this situation occurs.

On some extended-center wheels with small hub diameters, the pressure drum cannot contact the front face of the wheel properly. Such wheels can be mounted using the standard back cone method without a pressure drum. Check that the handle contacts the wheel center evenly and that the wheel is centered on the cone.



Double Cone Mounting

The cones must not touch each other. If the cones touch, the wheel will not be centered and mounted securely.

Double cone mounting can be used for some specialty wheels, such as those on a Porsche 928. The back cone centers on the formed part of the wheel, and the front cone centers on the hole.



Front Cone Mounting with an Extension Adaptor

The extension adaptor may be required for some light truck wheels and reverse-offset wheels that must be moved away from the balancer mounting flange. The extension adaptor is often used with the 5- $\frac{1}{2}$ -inch diameter light truck cone.

Install the extension adaptor on the mounting flange with the knurled thumbnuts provided. Then mount the wheel, using the normal front cone method.



Universal Wheel Adaptor

This adaptor is used on wheels with untrue center holes and wheels with closed center or for any application where automotive mounting cones can not be used. Instructions for use are supplied with the adaptor.



Metric Bolt Plate Adaptor

The metric bolt plate adaptor is an alternative to the universal wheel adaptor. The adaptor is used on wheels with untrue center holes, wheels with closed center holes as found on many French vehicles, or where the wheel is centered on the wheel mounting studs rather than by conical wheel mounting nuts. Instructions for use are supplied with the adaptor.



Wheel Mounting Errors

Regardless of the mounting method used, the wheel must be centered before balancing. A wheel should be mounted on the appropriate cone or adaptor and tightened carefully to ensure proper centering and mating against the balancer flange.

The wheel must be clean and free of large burrs or nicks, especially where it mates with the cone or adaptor and the balancer flange. Any dirt between the flange and the mating surface of the wheel will cause misalignment on the shaft. A misalignment of the thickness of a matchbook cover will cause an unbalance of 15 grams (0.50 ounce) or more on automobile wheels and 30 grams (1 ounce) on light truck wheels.

The wheel must also be tightened securely to prevent it from slipping in relation to the flange. If the wheel slips on the balancer, accurate weight measurement and location are impossible.

Wheel Rotational Errors

When a wheel is mounted on the balancer, whether using a cone or an adaptor, it is fixed in a particular position in relation to the balancer shaft. If the wheel is rotated 180 degrees from the initial position and retightening, a different balance reading may result. Such differences are called rotational errors.

When checking balance with the wheel in one position and then rotating it 180 degrees and re-spinning it, the difference between the two readings could be as much as 15 grams (0.50 ounce) for cone-mounted automobile wheels, and 60 grams (2 ounces) for light truck wheels.

The actual balance error is one-half of the displayed amount because the reading is the sum of the error and the weight required to counterbalance the error. To do a rotational test, first fine-balance the wheel. Then loosen the wheel on the shaft, rotate it 180 degrees, and retighten the handle. Spin the wheel in the normal mode to check for rotational errors.

POWER SOURCES

The balancer may be powered in three different ways.

1. Power Converter/Charger.

The normal power method is to use the power converter supplied with the equipment. This converter furnishes 8.5 VAC, with sufficient power to operate the equipment and charge the battery.

2. Battery.

The balancer is equipped with an 8 volt, 8.5 Ampere-Hour lead-acid, maintenance free, gel-cell battery (2 each Technacell 4 volt, 8.5 Amp-hour, Model EP485 or equivalent) to allow operation when normal power is not available. The normal power converter should be used to keep the battery charged whenever the balancer is not in operation. There is no need to unplug the converter since the battery can not be overcharged. It requires a minimum of 12 hours to fully charge the battery.

In cases where the battery is allowed to become fully discharged, the balancer will still operate normally from the power converter or an external 12 volt battery.

If the balancer is not used for approximately 10 minutes, the computer puts the equipment into a standby mode. This reduces the power consumption to less than one watt, except for the power required to charge the battery. If the balancer is being operated from the battery, the standby mode will continue to discharge the battery but at a very reduced rate.

Battery life can be expected to be approximately 5 years. Life can be extended by maintaining a full charge and avoiding excessive vibration and temperature variations. If the battery is replaced, care must be taken to reconnect with the correct polarity. If the polarity is reversed the 3 Amp fuse (type 3AG/AGC or equivalent) located in the battery compartment will blow. Should it be necessary to replace the fuse, **DO NOT** use a slow-blow type or any other rated battery.

Note: Black lead connects to the (-) terminal; Red lead with fuse connects to the (+) terminal.

3. 12v Battery Operation.

The balancer may be powered by any 12 volt battery. Connection is made to the same input connector as the normal power converter. In this case either polarity may be used, as the computer can operate from either a +12 volt or -12 volt DC source.

AUTOMATIC CALIBRATION

The Coats Truck Balancer is calibrated by computer before shipment and should not require recalibration in normal service. If the P.C.B. assembly or the back panel assembly is replaced, the balancer should be recalibrated. Additionally, if balancing results appear to be irregular, the balancer may require recalibration. The balancer contains a program for automatic self-calibration, which can be performed in about the same time that it takes to balance a single wheel.

Calibration Procedure

Follow this procedure to calibrate your balancer:

1. Fine balance a Wheel.

Balance a wheel in **Fine** resolution as explained in the *Balancing Operation* section. Use a wheel of the kind and size normally balanced on the balancer. The wheel must be balanced in the NORMAL (clip-on) mode. If the balancer is in the STATIC mode or any of the ALU/MAG modes, the calibration program will not operate.

Accurately set the knobs to the dimensions of the wheel.

2. Attaching Calibration Weight.

Rotate the wheel until both outer position arrows and the top-dead-center indicator light. Attach the Weight indicated below to the outer wheel rim at TDC.

- Car/Light Truck 100grams (3.00 ounces)
 (Diameter set at or below 17")
- Truck 400grams (12ounces)
 (Diameter set above 17")

3. Enter the Calibration Program.

Press and hold the Oz/gram button. While holding the Oz/gm button down, press and hold the Mode Select Button for 3 to 4 seconds. When the balancer enters the calibration program, the display will show a flashing 'ccc'.

4. Spin the Wheel at Least Four Times.

Spin the wheel up to the normal balancing speed. After the measuring cycle, a beep will sound and the flashing 'ccc' message will reappear on the display. Brake the wheel and re-spin again. Calibration usually requires four consecutive, accurate spins.

After the final accurate spin, the calibration weight will appear on the display for the outer rim flange, and zero will appear for the inner flange at TDC. Calibration is now complete.

5. Remove the Calibration Weight.

After successful calibration, the balancer stores the new calibration values in memory. Remove the calibration weight from the wheel and proceed with normal operation of your balancer.

If calibration is abandoned before completion, the original (previous) calibration values are retained.

Calibration Error

If an error occurs during any of the spin cycles, the 'EEE' error message appears on the display. The calibration program is aborted, and the balancer retains the previous calibration values.

The 'EEE' error message may result from using an incorrect calibration weight. Accidentally bumping the balancer during calibration also could cause an error message. To correct a calibration error, remove the calibration weight and spin the wheel to remove the 'EEE'. Then verify that the wheel is still Fine balanced and repeat the calibration procedure.

If calibration fails, try the calibration program again from the beginning. Changing the wheel and the calibration weight may correct a calibration failure. If the balancer repeatedly fails the calibration program, contact your distributor for assistance.

SERVICE AND MAINTENANCE

The Truck Wheel Balancer can be maintained with a few simple actions performed at regular intervals.

Wheel mounting accessories and the mounting surfaces of the flange and shaft of the balancer need to be cleaned regularly. Grease and oil will accumulate dirt which can cause incorrect balancing readings, and can also act as a grinding compound resulting in premature wear.

Old wheel weights and other material must be removed from under the balancer.

Ensure that tires, rims, tools or other parts are not left leaning against the balancer body.

Clean the display and input panels with a dry cloth.

If the balancer gets physically damaged or broken, Contact your COATS distributor.

Operational Check

1. Connect the power cord. Switch on the balancer. Press Mode several times. The Weight Mode indicators should light corresponding to each weight mode selected. Return to the Normal weight mode. Press Fine to set Fine Mode. The Fine indicator should light.
2. Mount a wheel on the balancer and program the wheel dimensions (diameter, width, offset), ensuring that the numeric display shows the values when the dials are moved.
3. Hand-spin the wheel up to speed.

4. Wait for the measuring cycle to complete (10-20 seconds). The inner and outer weights should be displayed when the wheel is rotated to the respective TDC positions.

5. Fine-balance the wheel to zero.

Attach a 100-gram (3-ounce) weight to the outer rim at the 12 o'clock position when the outer TDC indicator is lit. Spin the wheel and note the readings. Repeat with the weight moved to the light spot on the inner rim. The balancer is within calibration limits if the display shows 90 - 110 grams (2.75 - 3.25 ounces) for the side with the weight attached and shows 0 - 10 grams (0 - 0.25 ounces) for the side without the weight. If the readings are not within these limits, verify that the wheel dimensions are set correctly and perform the CALIBRATION procedure, before proceeding to the next step.

6. Remove the 100-gram (3-ounce) weight and verify that the wheel is balanced in Fine Mode.

7. Rotate the wheel 180° in relation to the mounting flange and re-spin. The sum of the inner and outer readings should be a maximum of 15 grams (0.50 ounces) for a 14" or smaller wheel. If the sum is higher, make sure the wheel is properly centered when tightening the hub nut. Clean the mounting surface, spindle, cones and wheel, and then repeat the check. If the new sum is also too high, repeat the check with a new wheel.

If the balancer fails any of the above steps, contact your service representative for assistance in correcting the problem.

TROUBLESHOOTING GUIDE

The following tips will help to identify and correct problems which may be encountered when using the Truck wheel balancer.

A. No indicators on the display panel are lit.

There may be no power supplied to the balancer or a cable may be loose.

- Ensure the power converter lead is inserted properly into the power input connector at the rear of the machine.
- Unplug the power converter. Remove the weight pockets and check all cable connections.

B. Display appears to freeze or lock up.

The power to the balancer may have been interrupted.

- Remove the battery and remove the power

C. Balancing results are inconsistent.

The balancer may not be resting on a solid and level surface, the mounting accessories or stub shaft may be worn or damaged, or the electronics assembly or sensors may have been replaced.

- Ensure that the balancer is fixed in position.
- Inspect the mounting accessories and stub shaft; replace if necessary.
- Perform the Calibration procedure.
- Move the balancer to a new location and try again (note that the balancer is heavy - do not move the balancer without assistance).

F. Spinning wheel by hand - 'EEE' is reported.

The wheel may have been spun in the wrong direction (anti-clockwise when facing the outer rim), or the wheel has been spun up to measuring speed (the balancer beeps once) and then slowed, or stopped, before the balancing cycle is completed.

- Re-spin the wheel, spinning it in the correct direction (clockwise when facing the outer rim).
- Ensure that the wheel is mounted properly and that the Hub Nut is securely tightening the wheel against the flange; the wheel must not slip on the shaft.
- Check that wheel movement is not being impeded.
- When only a wheel rim is mounted, the rim may be too light to maintain speed; try spinning the rim a little faster.

G. Balancer beeps continuously.

The wheel has been spun too fast by hand and is spinning above the measurement speed range, or there may be a fault in the electronics assembly.

- Wait until the wheel slows to a speed within the required range or carefully slow the wheel. The balancer will no longer beep when the wheel spins at the correct measuring speed, and will continue with the balancing cycle.
- If the balancer continues to beep even when the wheel is slowed or stopped, then the balancer should be switched off. Wait a few seconds and then turn on the power again.

H. The decimal point is constantly displayed.

The balancer is set to display weight units in ounces, or the display electronics are faulty.

- To change weight units, press Hidden button and then press Fine on the input panel. Hold both pressed for 3 seconds. The balancer will beep and the decimal point will be turned off.
- If this does not work, the electronics assembly should be replaced.

TECHNICAL SPECIFICATIONS

Rim diameter range: 330-660mm (13-26")

Rim width range: 101-457mm (4-18")

Rim offset range: 76-297mm (3-11")

Maximum wheel diameter: 1300mm (50.5")

Maximum wheel weight: 227kg (500lbs)

Using standard mounting accessories. The Coats is additionally capable of handling wheel weights of 500lbs (227Kg) using special mounting techniques at very large offsets. (ie. wheel and brake drum assemblies).

Power requirements:

Operates from 100/110/220/240 volt 50/60 Hz mains supply depending on power converter supplied or from its own built in rechargeable battery. Optional cable to connect to any 12 volt car battery.

Balancer weight: 104kg (229lbs)

Balancer dimensions:

- Height (H) 1145mm (45").
- Floor area (L x W) 980x915mm.
(42"x36").

Shipping weight: (B920) 176kg (387lbs)

Shipping dimensions:

- (L x W x H) (B920) 110"x100"x125"

Balancing modes:

- Truck: Normal (clip-on), 4 Alu/Mag, and static.
- Automobile: Normal (clip-on), 4 Alu/Mag, and static.

Balancing accuracy:

- Standard resolution: 25 grams (1 ounce) for truck wheels - 5 grams (0.25 ounce) for automobile wheels.
- Fine resolution: 5 grams (0.25 ounce) for truck wheels - 2 grams (0.10 ounce) for automobile wheels.

Balancing cycle: 8 to 20 seconds depending on wheel size.

Calibration: Automatic self calibrating.

The information and specifications in this manual are based on the latest information available at the time of publication. The product manufacturer reserves the right to change the specifications at any time without notice.

This product is protected under the following Patents,
and Patent Applications Pending:

U.S.A.	4,435,982 4,489,608 4,507,964 4,741,211 5,189,912 5,419,193
U.K.	GB 2 131 561 B GB 2 153 095 B
Canada	1,217,661 1,230,758
France	2 536 857 2 558 591
Japan	733740 06-065975 07-015423
Australia	574053 575371 625,780 661,552
Europe	0,358,496 (DE P689 21 271.2-08, GB, FR, ES, IT, NL)
Germany	DE 35 01 577 C2
Ireland	S 58405
Italy	1,182,123

COATS®

USA

HENNESSY INDUSTRIES, INC

P.O. Box 3002, 1601 J.P. Hennessy Dr., LaVergne, TN 37086-1982 (800) 688-6496

CANADA

HENNESSY CANADA

2430 Lucknow Dr., Unit #9, Mississauga, Ontario L5S 1V3 (416) 672-9440

HENNESSY INDUSTRIES, INC. Manufacturer of AMMCO,® COATS,® and BADA® Automotive Service Equipment and Tools.

COATS® is a registered trademark of Hennessey Coats Industries