

COATS®

1250 Series Wheel Balancer



1250-3DV Shown

See
★ **Balancing Your
First Tire**
on page 1.

Installation Instructions Operating Instructions Safety Instructions Maintenance Instructions

READ these instructions before placing unit in service KEEP these and other materials delivered with the unit in a binder near the machine for ease of reference by supervisors and operators.

HENNESSY INDUSTRIES, INC.

1601 J. P. Hennessy Drive, LaVergne, TN USA 37086-3565 615/641-7533 800/688-6359 www.ammcoats.com
HENNESSY INDUSTRIES INC. Manufacturer of AMMCO®, COATS® and BADA® Automotive Service Equipment and Tools.

Manual Part No.: 8114307 08
Revision: 03/08

IMPORTANT SAFETY INSTRUCTIONS

READ ALL INSTRUCTIONS

1. Eye and face protection recommendations:
“Protective eye and face equipment is required to be used where there is a reasonable probability of injury that can be prevented by the use of such equipment.” O.S.H.A. 1910.133(a) Protective goggles, safety glasses, or a face shield must be provided by the owner and worn by the operator of the equipment. Care should be taken to see that all eye and face safety precautions are followed by the operator. ALWAYS WEAR SAFETY GLASSES. Everyday glasses only have impact resistant lenses, they are not safety glasses.
2. Do not disable hood safety interlock system, or in any way shortcut safety controls and operations.
3. Be sure that wheels are mounted properly, the hub nut engages the arbor for not less than four (4) turns, and the hub nut is firmly tightened before spinning the wheel.
4. Read and understand this manual before operating. Abuse and misuse will shorten the functional life.
5. Be sure the balancer is properly connected to the power supply and electrically grounded.
6. Do not operate equipment with a damaged cord or if the equipment has been dropped or damaged – until it has been examined and repaired by a qualified serviceman.
7. Do not let cord hang over edge of table, bench, or counter or come in contact with hot manifolds or moving fan blades.
8. If an extension cord is necessary, a cord with a current rating equal to or more than that of the equipment should be used. Cords rated for less current than the equipment may overheat. Care should be taken to arrange the cord so that it will not be tripped over or pulled.
9. Keep guards and safety features in place and in working order.
10. Wear proper clothing. Safety toe, non-slip footwear and protective hair covering to contain hair is recommended. Do not wear jewelry, loose clothing, neckties, or gloves when operating the balancer.
11. Keep work area clean and well lighted. Cluttered and/or dark areas invite accidents.
12. Avoid dangerous environments. Do not use power tools or electrical equipment in damp or wet locations, or expose them to rain.
13. Avoid unintentional starting. Be sure the balancer is turned off and power disconnected before servicing.
14. Disconnect the balancer before servicing.
15. Use only manufacturer’s recommended accessories. Improper accessories may result in personal injury or property damage.
16. Repair or replace any part that is damaged or worn and that may cause unsafe balancer operation. Do not operate damaged equipment until it has been examined by a qualified service technician.
17. Never overload or stand on the weight tray or any part of the balancer.
18. Do not allow untrained persons to operate machinery.
19. To reduce the risk of fire, do not operate equipment in the vicinity of open containers or flammable liquids (gasoline).
20. Adequate ventilation should be provided when working on or operating internal combustion engines.
21. Keep hair, loose clothing, fingers, and all parts of body away from moving parts.
22. Use equipment only as described in this manual.
23. Use only manufacturer’s recommended attachments and accessories.

SAVE THESE INSTRUCTIONS

Safety

Owner's Responsibility

To maintain machine and user safety, the responsibility of the owner is to read and follow these instructions:

- Follow all installation instructions.
- Make sure installation conforms to all applicable Local, State, and Federal Codes, Rules, and Regulations; such as State and Federal OSHA Regulations and Electrical Codes.
- Carefully check the unit for correct initial function.
- Read and follow the safety instructions. Keep them readily available for machine operators.
- Make certain all operators are properly trained, know how to safely and correctly operate the unit, and are properly supervised.
- Allow unit operation only with all parts in place and operating safely.
- Carefully inspect the unit on a regular basis and perform all maintenance as required.
- Service and maintain the unit only with authorized or approved replacement parts.
- Keep all instructions permanently with the unit and all decals/labels/notices on the unit clean and visible.
- Do not override safety features.

Operator Protective Equipment

Personal protective equipment helps make tire servicing safer. However, equipment does not take the place of safe operating practices. Always wear durable work clothing during tire service activity. Loose fitting clothing should be avoided. Tight fitting leather gloves are recommended to protect operator's hands when handling worn tires and wheels. Sturdy leather work shoes with steel toes and oil resistant soles should be used by tire service personnel to help prevent injury in typical shop activities. Eye protection is essential during tire service activity. Safety glasses with side shields, goggles, or face shields are acceptable. Back belts provide support during lifting activities and are also helpful in providing operator protection. Consideration should also be given to the use of hearing protection if tire service activity is performed in an enclosed area, or if noise levels are high.

Definitions of Hazard Levels

Identify the hazard levels used in this manual with the following definitions and signal words:

DANGER

Watch for this symbol:



It Means: Immediate hazards, which will result in severe personal injury or death.

WARNING

Watch for this symbol:



It Means: Hazards or unsafe practices, which could result in severe personal injury or death.

CAUTION

Watch for this symbol:



It Means: Hazards or unsafe practices, which may result in minor personal injury or product or property damage.



Watch for this symbol! It means BE ALERT! Your safety, or the safety of others, is involved!

Safety Notices and Decals



Failure to follow danger, warning, and caution instructions may lead to serious personal injury or death to operator or bystander or damage to property. Do not operate this machine until you read and understand all the dangers, warnings and cautions in this manual. For additional copies of either, or further information, contact:

Hennessy Industries, Inc.
1601 J.P. Hennessy Drive
LaVergne, TN 37086-3565
(615) 641-7533 or (800) 688-6359
www.ammcoats.com

The motor unit of this machine contains a Class IIIa laser with a maximum output less than 5mW at a wave length of 630-680 nm. **Avoid Exposure - Laser radiation is emitted from its aperture.**



Use of controls, adjustments or performance of procedures other than those specified herein may result in hazardous radiation exposure.

In case of failure, the entire motor unit must be replaced.



This product, incorporating a laser, has been tested to the requirements of CDRH 21CFR and complies with standards 21CFR1040.10 and 21CFR1040.11

Hennessy Industries, Inc.
1601 J.P. Hennessy Drive
LaVergne, TN 37086

Manufactured:

8113909 01

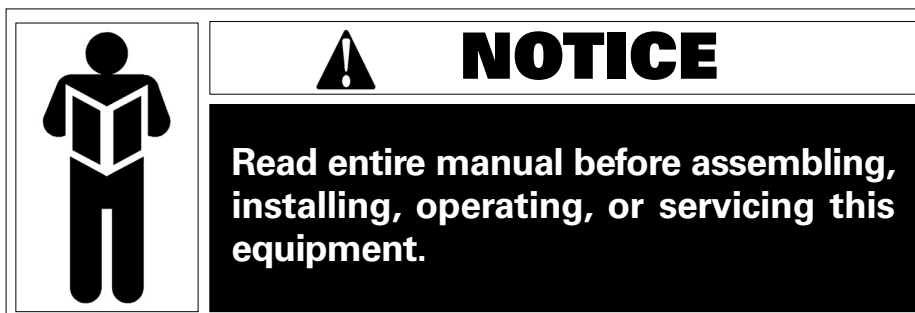

⚠ WARNING

Risk of Injury
 This machine is provided with a wheel guard interlock. Do not defeat it's purpose.

8111840 02

⚠ WARNING

Maximum Size of Wheel Rating

Weight	Diameter	Width
160 lbs.	44 in.	20 in.

Maximum Duty Cycle
30 Wheels/Hour @ 160 lbs.

8113570 01

⚠ WARNING

RISK OF EXPLOSION
 This equipment has internal arcing or sparking parts which should not be exposed to flammable vapors. Do not locate in a recessed area or below floor level.

THIS EQUIPMENT MUST BE EARTH-GROUNDED
 The earth-ground connector built into the power cord provides protection to reduce the risk of electrical shock.

⚠ CAUTION

Do not use below garage floor or grade level.
 Disconnect power before servicing this equipment.
 To prevent electrical shock, do not remove cover. No user servicable parts inside. Refer servicing to qualified service personnel.

May Be Protected by one or more of the following patents:
 USA - 4,423,632 - 4,499,768 - 4,939,941 - 5,311,777 - 5,337,256
 AUSTRALIA - 564038

8113547 01



Standard Safety Devices

- STOP key for stopping the wheel under emergency conditions.
- A hood guard of high impact plastic that is designed to prevent the counterweights from flying out in any direction except towards the floor.
- A hood switch interlock system that prevents the machine from starting if the guard is not lowered and stops the wheel whenever the guard is raised.

Table of Contents

Important Safety Instructions	ii	Installation Instructions	20
Owner's Responsibility	iii	Receiving	20
Operator Protective Equipment	iii	Electrical Requirements	20
Definitions of Hazard Levels	iii	Setup	20
Safety Notices and Decals	iv - v	Connect to Power	20
Standard Safety Devices	v	Floor and Space Requirements	20
*Balancing Your First Tire	1	Specifications	21
Principle Operating Parts	3 - 6	Features	21
Know Your Unit	3	Accessories Options	21
Power Switch	3		
Using The Offset Arm	4 - 5		
Using The Laser Locator	5		
Using The Line Laser	5		
Using The Hood Sonar (if equipped)	5		
Laser Guided Operation™ System	6		
Setting Wheel Dimensions (DIM)	7		
Definition of Dimensions (DIM)	7		
Basic Wheel Data Entry	7		
Entering Wheel Dimensions Manually	7		
Control Panel Function and Review	8 - 11		
Control Panel Quick Reference	8 - 9		
Screen Saver Mode (Video)	10		
Weight Display and Weight Position Windows	10		
Mode Indicators	10		
Direct Select™ Weight Location	11		
Information Box	11		
Balance Options	11		
Keypad Group	11		
Balancing Modes	12 - 13		
Dynamic Modes	12		
Static Modes	12		
EB Mode	12		
Special Modes	12 - 13		
Mounting Wheel on Spindle Shaft	14 - 15		
Standard Back Cone Mounting	14		
Standard Front Cone Mounting	15		
Alternate Mounting	15		
Match Balance (Optimization)	16		
Match Balance Mode	16		
Machine Calibration	17		
Calibration	17		
Maintenance Instructions	18		
Diagnostic Procedures	19		
After Balance Vibration Problems	19		
Troubleshooting	19		

★Balancing Your First Tire

1. Turn the machine OFF then ON (resets machine).

Note: The machine wakes up using standard clip-on wheel weight locations (Clip 1 & Clip 2) and wheel dimensions.

2. Mount a tire/wheel on the balancer that will use standard clip-on wheel weights.

Use the most appropriate mounting method.

3. Always remove any weights already attached to the wheel.

4. Enter A & D wheel dimensions using offset arm.

For Automatic Measurement — pull offset arm out to the wheel, hold it still at clip-on weight position against wheel flange, and wait for BEEP. Return arm to home position.

Clip-on Weight Location — viewed on a cut-away rim for clarification.

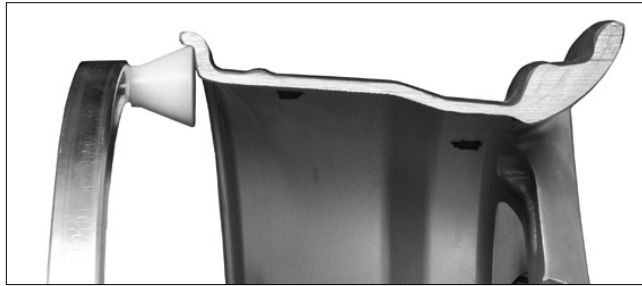

Figure 1 - Clip-On Weight Location

Note value entry of A & D dimension.

5. Enter Width wheel dimension.

For Manual Entry — Use plastic calipers to measure wheel width. Press W key. Use keypad to enter Width value (between 2.0 and 20.0 inches).

For Automatic Measurement — Lower hood.

Note value entry of W dimension.

6. Lower the hood; wheel spins and unbalances are measured and displayed.

The corrective weight amount appears in the weight display window for inboard (left plane) and outboard (right plane) weight locations.

7. Raise hood after tire stops rotating.

Note: Wait for wheel to stop before raising the hood.

8. Rotate wheel until inboard (left plane) center bar blinks.

9. Attach inboard (left plane) corrective weight.

Attach specified weight amount at top-dead-center on inside flange of wheel.

10. Rotate wheel until outboard (right plane) center bar blinks.

11. Attach outboard (right plane) corrective weight.

Attach specified weight amount at top-dead-center on outside flange of wheel.

12. Lower the hood to respin the tire/wheel and check balance.

Your weight readings should now be 0.00.

Note: Throughout this manual tire dimensions are referred to as A, W, and D, see figure 2.

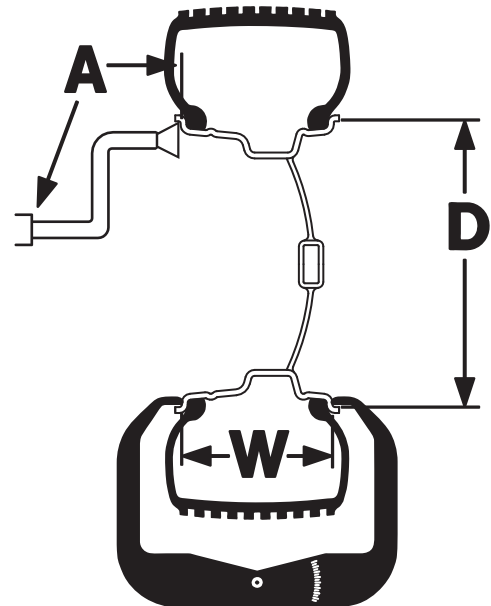

Figure 2 - A, W, and D Tire Dimensions

Principle Operating Parts



1250 Non-video Shown



Do It Now!

Now is a good time to fill out the Owner's Registry Card.

Know Your Unit

Compare this illustration with the unit before placing it into service. Maximum performance and safety will be obtained only when all persons using the unit are fully trained in its parts and operation. Each user should learn the function and location, of all controls.

Prevent accidents and injuries by ensuring the unit is properly installed, operated and maintained.

- A Control Panel or Video Display Panel**
- B Plug (back of machine)**
- C ON/OFF**
- D Weight Tray with Dual Pockets for Weights thru 2 oz. - Deep Pockets thru 4 oz**
- E Line Laser**
- F Locator Laser**
- G 1-1/8-inch\40mm Shaft**
- H Offset Arm, Measures A & D of Tire/Wheel (shown in home position)**
- J Hood Guard**
- K Hood Sonar - Width Sensor (if equipped)**

Note: Throughout this manual wheel weights are referred to as Clip-on or Tape-A-Weight™. Figure 3 shows an example of each weight.

Figure 3 - Corrective Weight Examples. For Best Results, use BADA® Brand Wheel Weights.



Power Switch

The ON/OFF decal (figure 4) indicates the ON/OFF switch location at the back of the balancer.



Figure 4 - On/Off Switch

Using The Offset Arm

When not in use or when prompted by the balancer instructions, store the offset arm in the home position as shown in figure 5.

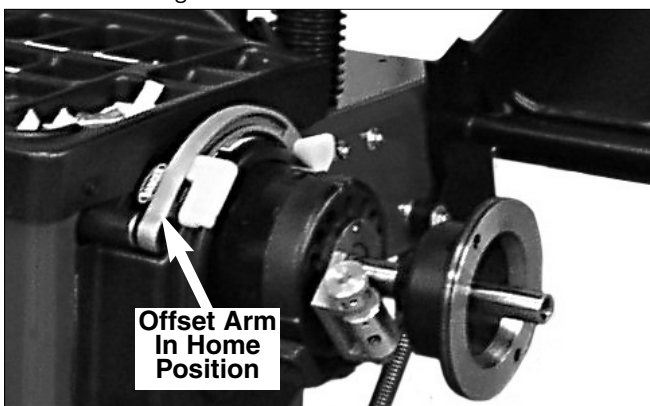

Figure 5 - Offset Arm Stored In Home Position

When prompted by balancer instructions, use the offset arm (figure 6A) to enter A & D measurements automatically. Pull the arm out and up against the wheel flange; hold it still at the clip-on weight location (figure 6B), against the wheel flange, and wait for the BEEP.



Figure 6A - Automatic A&D Measurement At Clip-on Weight Location

Be sure to place the offset arm on the wheel flange at the clip-on weight location as shown figure 6B.

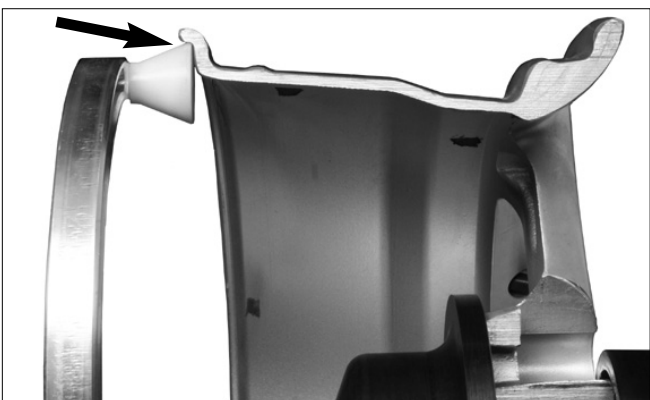

Figure 6B - Clip-on Weight Location Viewed on a Cut-Away Rim for Clarification.

Note: Use the offset arm to automatically measure the A & D dimension for all balancing modes except Patch Static (refer to page 12).

Note: Refer to page 7 to measure the A dimension manually using the offset arm.

If the T2 - Tape (hidden Tape-A-Weight®) location is selected, use the offset arm to enter A2 & D2 measurements automatically. After the A & D measurement is entered, move the arm from the clip-on weight location to the inner area of the wheel; up against the rim at the outboard (right plane) weight placement location (see figures 7A & 7B). Wait for the BEEP.

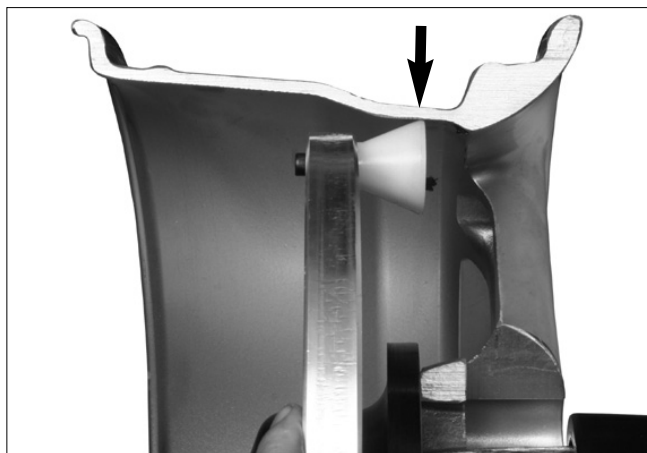

Figure 7A - Hidden Weight Location Viewed on a Cut-Away Rim for Clarification.

Note: The T2 - Tape Direct Select™ Weight position is the only mode that requires the A2 & D2 dimension measurements.

Important: The A2 measurement must be at least 2 inches greater than the A1 measurement.

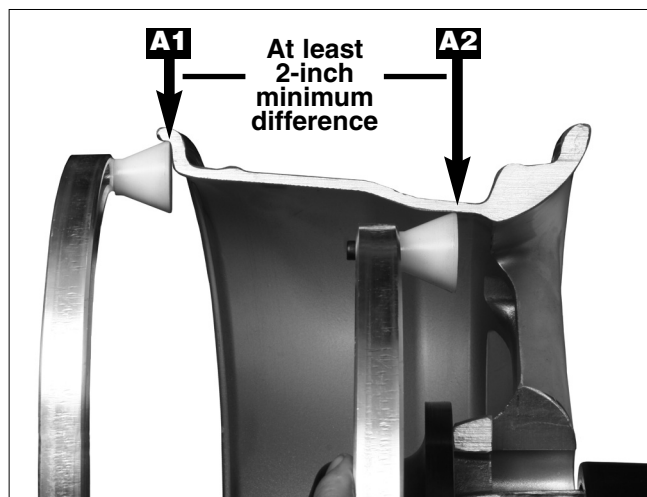

Figure 7B - T2-Tape (Hidden Tape-A-Weight®) Keep At Least 2-inches Between A1 and A2 Measurement

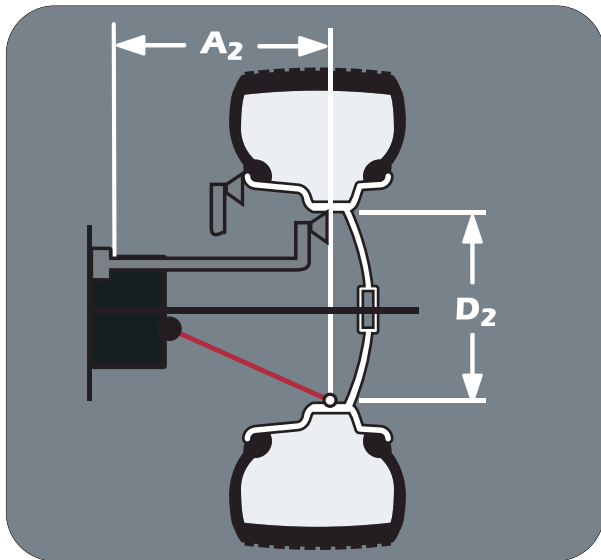

Figure 7C - T2-Tape (Hidden Tape-A-Weight®) Data Entry Diagram

Using The Laser Locator

If the T2 - Tape (hidden Tape-A-Weight®) location is selected, use the laser locator to point to the hidden weight location (figures 8 & 7B). Rotate laser locator knob to position the laser dot outboard (right plane) at the desired T2-Tape (hidden Tape-A-Weight™) location.

Note: For best performance, choose a weight position outboard (right plane) as far inward (in the rim) as wheel allows.

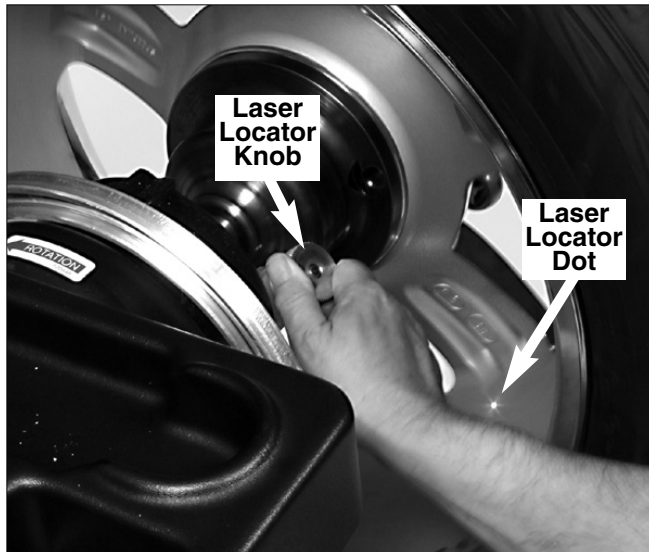

Figure 8 - Positioning Laser Dot At T2 - Tape Hidden Weight Location (A2)

Note: The T2 - Tape Direct Select™ Weight position is the only mode that requires the A2 & D2 dimension measurements.

Using The Line Laser

If the T2 - Tape (hidden Tape-A-Weight®) location is selected, use the line laser to align the offset arm with the laser locator dot (figures 8 & 7B); entering A2 & D2 measurements automatically. Grasp arm at the line laser and pull out and up to the wheel flange (figure 6B). Hold arm still at the clip-on weight location and wait for BEEP. Then, before returning arm to home position, press button on line laser to activate the line laser beam. Move arm to inner area of wheel and align line laser beam with laser locator dot (figure 8). Hold arm still, up against the rim, in the same plane as the T2-Tape (hidden Tape-A-Weight™) location (figure 7A & 7B) and wait for BEEP. Refer to figure 9.

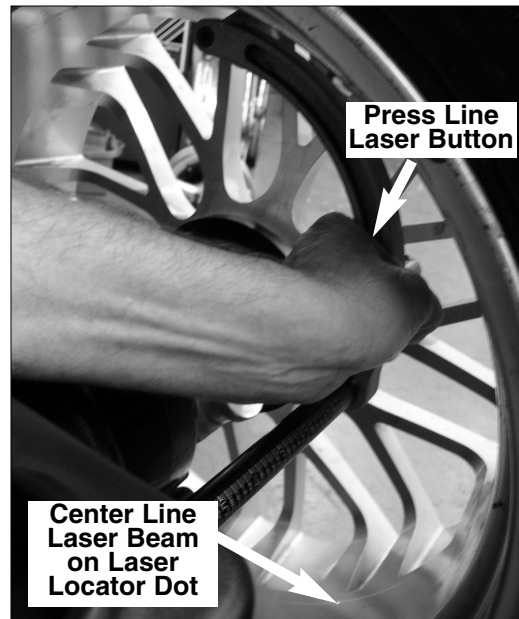

Figure 9 - Positioning Line Laser Beam At T2 - Tape Hidden Weight Location (A2)

Using the Hood Sonar (If equipped)

When prompted by the balancer instructions, use the hood sonar - width sensor (figure 10) to enter wheel width measurement automatically. Lower balancer hood guard to enter the measurement.



Figure 10 - Tire Width Sonar Located Inside Hood

Note: Refer to page 7 to measure the W dimension manually using the plastic calipers.

Laser Guided Operation™ System

The operator must select **T2 - Tape** Laser Locator to activate the Laser Guided Operation™ feature, see page 8 for the button selection. This Direct Select™ weight location is used when placing hidden adhesive weights at the inner area of the wheel and is the required weight location selection for the Behind Spoke mode.

Follow these steps to use the Laser Guided Operation™ feature for accurate placement of hidden Tape-A-Weights™:

Important: Only use the Direct Select Weight position **Clip 1 or T1 - Tape** and **T2 - Tape** (location illuminated). Refer to USING THE OFFSET ARM on page 4 and USING THE LASERS on page 5.

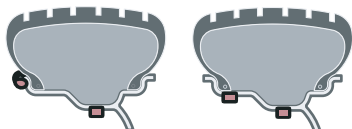

1. Begin by mounting the wheel assembly.

2. Be sure to Direct Select™ **T2 - Tape** as the outboard (right plane) weight location (refer to Dynamic Mode, Hidden Tape-A-Weights, page 12).

Note: The laser locator dot activates and blinks.

3. Rotate the laser locator knob to position the laser locator dot at the desired weight location. See figures 8 & 7B.

Note: For best performance, choose a weight position outboard (right plane) as far inward (in the rim) as wheel allows.

4. Enter the A & D wheel measurements, wait for BEEP. Then, before returning arm to home position, move arm to inner area of wheel and position the line laser beam at the **T2 - Tape** laser locator dot position; wait for BEEP.

5. Lower hood; wheel spins.

6. When unbalance is displayed, rotate wheel until inboard (left plane) center bar blinks. Attach inboard (left plane) corrective weight at top-dead-center.

7. Next, rotate wheel until outboard (right plane) center bar is steady and the two bars on either side blink.

Note: The laser locator dot will stop blinking.

8. Center and attach the outboard (right plane) corrective weight at laser locator dot location as shown in figure 11.

9. Respin tire/wheel to check balance.

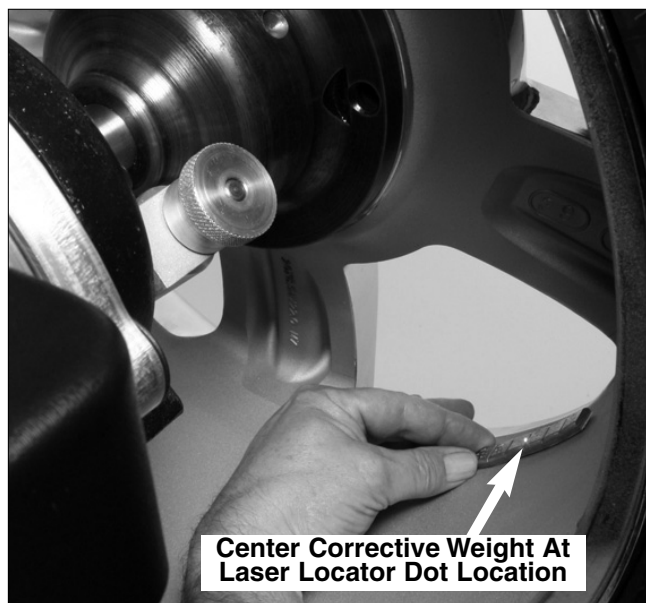

Figure 11 - Centering Corrective Hidden Weight At Laser Locator Dot Location

Setting Wheel Dimensions (DIM)

Before a wheel can be balanced, wheel dimensions must be entered into the computer.

Definition of Dimensions (DIM)

A = Offset The distance measured from the balancer ("0" on offset arm) to inner plane of the rim (inner weight location).

W = Width The width of the wheel at the rim flanges, measured with the calipers as shown in figure 13A.

Note: Only use calipers provided by the wheel balancer manufacturer because others may not be the same.

D = Diameter The diameter of the wheel as indicated on the tire.

Note: A thick flange, on some aluminum wheels, can effect the measured diameter. For example, a 16-inch rim can have a measured diameter of 15.5-inches.

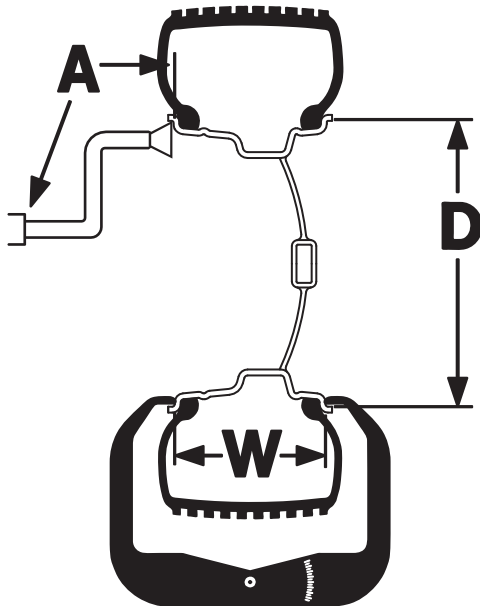

Figure 12 - A, W, and D Tire Dimensions

Basic Wheel Data Entry

1. Select the **Clip 1 or T1 -Tape** weight location and the **T3 -Tape or Clip 2** weight location.
2. Position offset arm at clip weight location; wait for BEEP (A & D enters automatically).
3. Return offset arm to home position.
4. Use caliper and measure rim width.
5. Enter caliper measurement into W on balancer.
6. Lower hood and spin wheel.

Entering Wheel Dimensions Manually

Note: To manually enter the A2 offset, press SHIFT A. To manually enter the D2 offset, press SHIFT D.

Wheel Offset - A

1. Press the A (wheel offset) key.
2. Position offset arm at weight location on wheel and read the number on the offset arm gauge, at the cabinet (this is the correct offset A DIM).
3. Use the keypad to enter the measurement.

Wheel Diameter - D

1. Press the D (wheel diameter) key.
2. Inspect mounted tire sidewall to determine the exact diameter that is printed on the tire.
3. Use the keypad to enter the D (Diameter DIM) to match the tire sidewall size.

Wheel Width - W

1. Press the W (wheel width) key.
2. Use the plastic calipers provided with the wheel balancer to measure the wheel width.

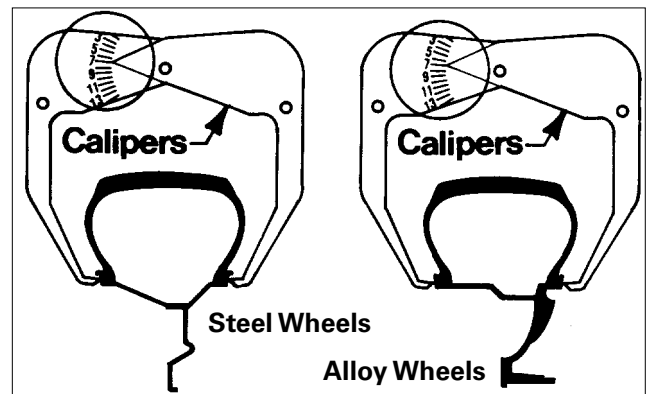

Figure 13A - Caliper Location Diagrams



Figure 13B - Caliper Placement On Wheel

3. Use the keypad to enter the W (Width DIM) to match the measured caliper width of the mounted rim.

Note: Information entered into balancer for A, W, and D can be changed at anytime during the balancing procedure. Follow instructions for entering the measurements manually. The balancer will recalculate weights and positions based on the new measurements.

Control Panel Function and Review

Control Panel Quick Reference

If you select/press ...	Then ...
a Direct Select Weight key (Clip 1, T1-Tape, Patch Static, T2-Tape, T3-Tape, or Clip 2)	on the Wheel Cross-section diagram, the activated weight location illuminates.
the T2-Tape key	the laser indicator illuminates; Laser Guided Operation™ mode activates.
the Dynamic/Static key (s)	additional balance modes may be accessed. For additional information, see Balance Options, page 11.
the Behind Spoke key	the indicator illuminates showing the mode is on.
the Spoke 1/Spoke 2 key	the indicator illuminates showing the activated spoke location.
a Wheel Dimension key (A, D, or W)	enter wheel data manually using the “numbered” keys.
the Next key	additional functions or instructions may be accessed.
the Stop & Exit key	a measurement cycle or function is ended.
hold Shift and press 1	the Calibrate Machine mode is activated.
hold Shift and press 4	either 0.25-ounce Standard roundoff or 0.50-ounce RV-Lite Truck (RV mode indicator illuminates) is toggled on.
hold Shift and press 5	the Match Balance indicator illuminates showing the mode is on.
hold Shift and press 6	either the 0.25-ounce or 0.01-ounce weight increment is toggled on.
hold Shift and press 7	either the Operator A or the Operator B mode illuminates to indicate the active operator memory.
hold Shift and press 8	Hood Start is turned On or Off.
hold Shift and press 9	either ounce or gram weight measurements is toggled on.

(See Figure 14A or 14B)

- 1 Weight Display Windows**
- 2 Mode Indicators**
- 3 Left Weight Position Bars**
- 4 Right Weight Position Bars**
- 5 Direct Select™ & Wheel Cross-section Diagram**
- 6 Information Box**
- 7 Balancer Options**
- 8 Keypad Group**
- 9 Instructional Panel**

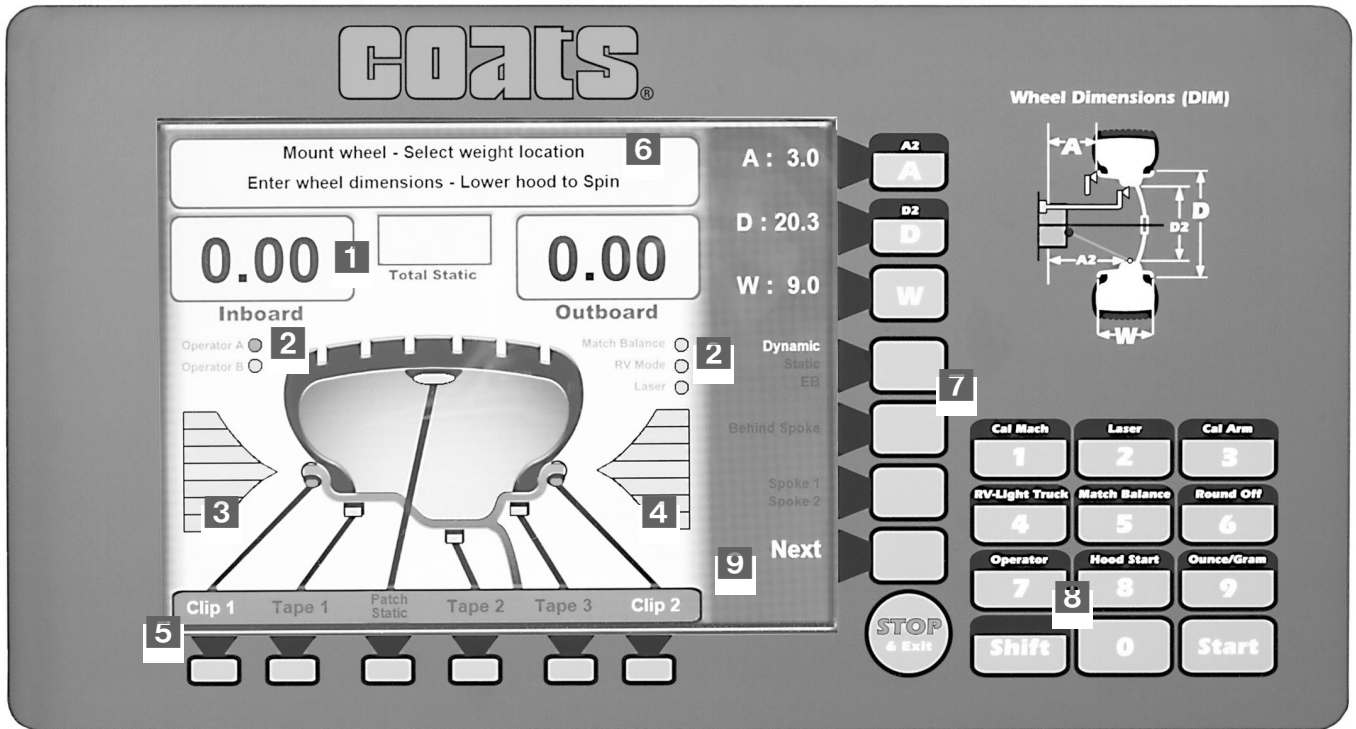

Figure 14A - 1250 Video Control Panel Feature Reference

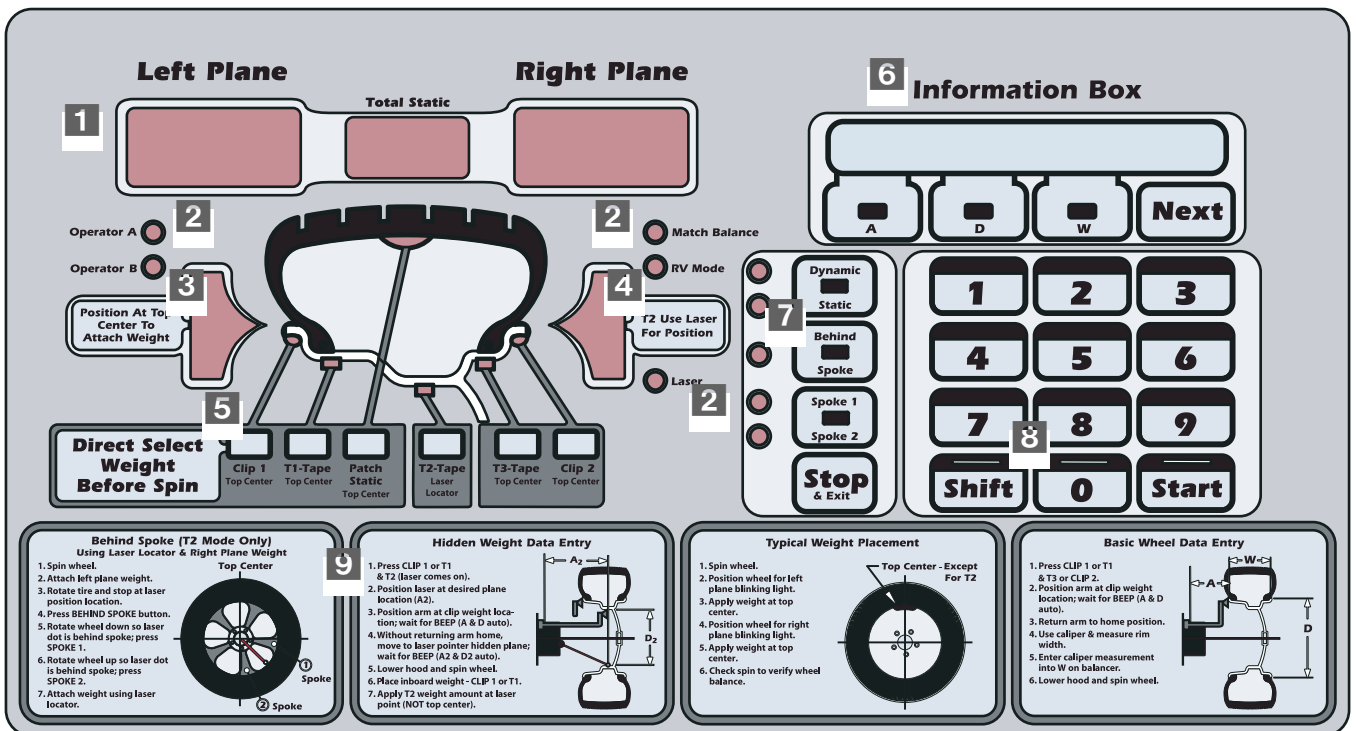

Figure 14B - 1250 Non-video Control Panel Feature Reference

Screen Saver Mode (Video)

By default, the 1250 video version wheel balancer is shipped with the screen saver mode set to dim the display back light after a period of inactivity (20 minutes).

Press and hold the SHIFT key and press 0; then 18 to cycle through the screen saver modes. For each mode, the balancer will display a short demo of the active back light option. The mode options are as follows:

Back light Option	Screen Saver Mode
Light Goes Dim	Dim Mode
Never Off	Awake Mode
Turns Off	Sleep Mode

In most cases, to reactive the back light, just mounting a wheel, rotating the wheel or pressing a key will provide the input to wake the balancer back up.

Weight Display and Weight Position Windows

Two weight display windows, one inboard (left plane) and one outboard (right plane), are positioned above the wheel cross section diagram. After a wheel measurement cycle, the balancer calculates the corrective weight amount and indicates it in the appropriate display window. All weight readings are shown in ounces or grams.

The "Total Static" window indicates the value of the total static unbalance. See MATCH BALANCE (Optimization) on page 16 for further details.

Located on either side of the wheel cross section diagram are the weight position bars, one inboard (left plane) and one outboard (right plane). After a measurement cycle, rotate wheel until the center weight position bar blinks, indicating the correct weight placement position is at top-dead-center.

Note: When in laser mode (T2-Tape Laser Locator), special blinking bars appear on either side of the center bar to indicate the correct outboard (right plane) weight placement position.

Mode Indicators

The mode indicator will show whether the mode is activated. Modes are as follows:

Operator A or Operator B - when illuminated, indicates which operator memory is selected.

Match Balance - when illuminated, indicates that the Match Balance (Optimization) mode is activated.

RV Mode - when illuminated, indicates that the 0.50-ounce RV (heavy wheels) mode is activated.

Laser - when illuminated, indicates that the Laser Guided Operation™ system is activated.

Dynamic or Static - press to cycle through balance modes. For additional information, see Balance Options, page 11.

Behind Spoke - when illuminated, indicates that the behind spoke mode is activated.

Spoke 1 or Spoke 2 - when illuminated, indicates spoke location selection.

Direct Select™ Weight Location

Before spinning the wheel, use direct select to indicate weight placement locations as follows:

Note: When the machine is turned ON, the balancer defaults to a 2-plane dynamic mode using standard clip-on wheel weight locations (Clip 1 and Clip 2) and wheel dimensions.

Clip 1 Top Center - select this location to place a standard clip weight on the inboard (left plane) rim flange.

T1 Tape Top Center - select this location to place an adhesive weight on the inboard (left plane) side of the wheel that is the horizontal plane at the outer edge.

Patch Static - select this location for a patch weight centered inside the tire. See PATCH WEIGHT BALANCE on page 13 for further details.

T2 Tape Laser Locator - select this location to place an adhesive (hidden) weight on the outboard side (right plane) of the wheel that is a horizontal plane in the inner area. See LASER GUIDED OPERATION™ SYSTEM on page 6 for further details.

T3 Tape Top Center - select this location to place an adhesive weight on the outboard (right plane) side of the wheel that is the horizontal plane at the outer edge.

Clip 2 Top Center - select this location to place a standard clip weight on the outboard (right plane) rim flange.

Information Box

Displays A, W, and D values, functions, and instructions for the operator. Error messages will also be shown in this display.

Balance Options

The indicator will illuminate to show the active balance option. Functions are as follows:

Dynamic/Static - press the respective key to cycle through either a Dynamic, a Dynamic with Total Static displayed, a Static, or the EB (if feature is enabled, see page 12 EB Mode) balance mode.

LED Indicators for 1250 Non-video

LED Status	Balance Mode
Both LEDs Lit	Dynamic
Top LED Lit	Dynamic/Total Static
Bottom LED Lit	Static
Neither LED Lit	EB

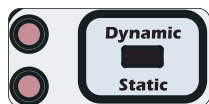

Behind Spoke - toggle the Behind Spoke option on or off. See BEHIND SPOKE on page 12 for further details.

Spoke 1/Spoke 2 - toggle to set the Spoke 1 location and the Spoke 2 location for adhesive weights (hidden weights).

Keypad Group

The operator enters wheel data information, selects functions, and sets options using these keys.

“Numbered” Keys - use to enter wheel data values.

Cal Mach - press and hold the SHIFT key and press 1 to activate Calibrate Machine mode. See MACHINE CALIBRATION on page 17 for further details.

RV-Lite Truck - press and hold the SHIFT key and press 4 to toggle between either the 0.25-ounce standard roundoff (most wheels) or 0.50-ounce RV-Lite Truck (heavy wheels) mode. The default is standard roundoff.

Match Balance - press and hold the SHIFT key and press 5 to select the Match Balance mode. See MATCH BALANCE (Optimization) on page 16 for further details.

Round Off - press and hold the SHIFT key and press 6 to toggle between either 0.25-ounce or 0.01-ounce weight increments. The default is 0.25-ounce.

Operator A/B - press and hold the SHIFT key and press 7 to toggle between two operator memories (A or B). The default memory is Operator A.

Hood Start - when on, sets the balancer to automatically start the spin cycle as soon as the hood is lowered completely and the hood safety interlock system is engaged. Press and hold the SHIFT key and press 8 to toggle Hood Start on or off. The default is on.

Ounce/Gram - press and hold the SHIFT key and press 9 to toggle between either ounce or gram weight measurements. The default is ounce.

Stop & Exit - press STOP to end a measurement cycle or exit a function.

Start - press START to begin a measurement cycle, if the hood is lowered.

Next - function key used when accessing balancer instructions.

Shift - function key used when accessing balancer modes or options.

Balancing Modes

A variety of wheel configurations can be balanced using this wheel balancer. Read through this section, it will help in determining which mode and options are best suited for certain wheel assemblies. Refer to pages 1 - 7 to balance the wheel, for measurement, and, weight placement techniques. Refer to pages 8 - 11 for Control Panel functions.

Remember: As with any balancing procedure, first remove any weights attached to the wheel, inspect the tire and wheel, and use the most appropriate balancer mounting method before beginning.

Dynamic Modes

Choose a dynamic balance to balance a wheel using two planes for correction. Direct Select™ the weight option that best fits the available weight locations.

Clip-on Weights - The default; used for most passenger and light truck tire assemblies using the most common location for corrective weights. Clip-on weights are placed on the inner and outer rim flanges.

Have the following items handy: appropriate style clip-on weights.

Direct Select Weight position **Clip 1** and **Clip 2** (weight locations illuminate). At these locations place the corrective weight amount at top-dead-center.

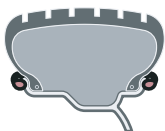

Tape-A-Weights® and Hidden Tape-A-Weights® - Used when one or both clip-on weight locations are not possible or desired. Select the weight location(s) that best fits the rim configuration.

Have the following items handy: appropriate style clip-on weights and Tape-A-Weights™.

Direct Select Weight position **Clip 1 or T1 - Tape** and **T2 - Tape, T3 - Tape or Clip 2** (weight locations illuminate). At all locations, except T-2 Tape, place the corrective weight amount at top-dead-center. If the T2 - Tape weight location is selected, the balancer activates its Laser Guided Operation™ feature (see page 6).

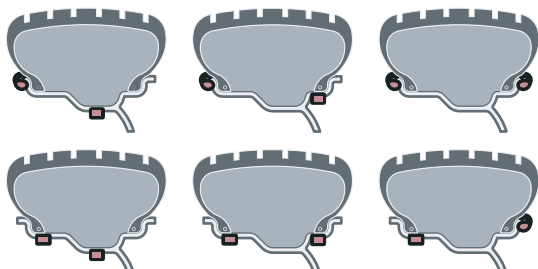

Static Modes

Choose a static balance for wheel assemblies that are not possible to balance dynamically or for narrow wheels. For example, a motorcycle wheel that has a small wheel width.

Have the following items handy: an appropriate wheel assembly mounted on the balancer and a selection of weights.

When in static mode, the only active Direct Select Weight location is **Clip 1 or T2 - Tape**. Select the weight location(s) that best fits the rim configuration.

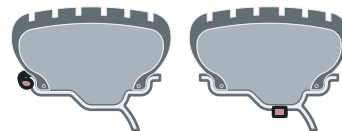

At the Clip 1 location, place the corrective weight amount at top-dead-center. If the T2 - Tape weight location is selected, the balancer activates its Laser Guided Operation™ feature (see page 6).

EB Mode

EB is an alternate approach to balancing a tire and wheel assembly. The technology seeks first to eliminate the static imbalance in a wheel assembly then, based on several parameters, calculates the minimum amount of corrective weight needed to bring dynamic imbalance within acceptable limits.

Balancing wheel assemblies using EB often results in the application of less corrective weight. In addition to the potential direct savings in wheel weights, there is a potential productivity savings due to a reduction in the number of "re-spins" necessary to achieve an acceptable balance condition.

To enable the EB function, press and hold the SHIFT key and press 0, then press 71 to toggle the EB mode ON or OFF (software version 2.0.1.6 and forward). The default is OFF.

For additional information, see Balance Options on page 11.

Special Modes

Choose a special mode option for the following special type wheel assemblies.

Behind Spoke (T2 - Tape Mode Only) - Used to balance with two adhesive weights located behind the spokes in the outer correction plane.

Only use the Direct Select Weight position **Clip 1 or T1 - Tape** and **T2 - Tape** (weight locations illuminate).

When the T2 - Tape weight location is selected, the balancer activates its Laser Guided Operation™ feature (see page 6).

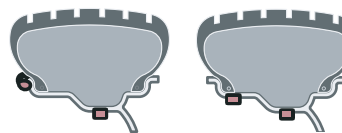

Begin by following the Laser Guided Operation™ procedure, steps 1 through 4 on page 6.

1. When unbalance is displayed, rotate wheel until inboard (left plane) center bar blinks. Attach inboard (left plane) corrective weight at top-dead-center.

2. Next, rotate wheel until the outboard (right plane) center bar blinks and the two bars on either side blink.

Note: The laser locator dot will stop blinking.

3. Select the BEHIND SPOKE mode option.

Important: Be sure that the Spoke 1 and Spoke 2 locations are on either side of the original outboard (right plane) corrective weight location, as shown in figure 15.

4. Rotate the wheel toward front so the laser locator dot is behind the first spoke; press SPOKE 1 (indicator illuminates).

5. Rotate the wheel toward rear so the laser locator dot is behind the second spoke; press SPOKE 2 (indicator illuminates). Now at the spoke 2 location, the outboard (right plane) center bar stops blinking and the two bars on either side blink.

Note: The laser locator dot will stop blinking.

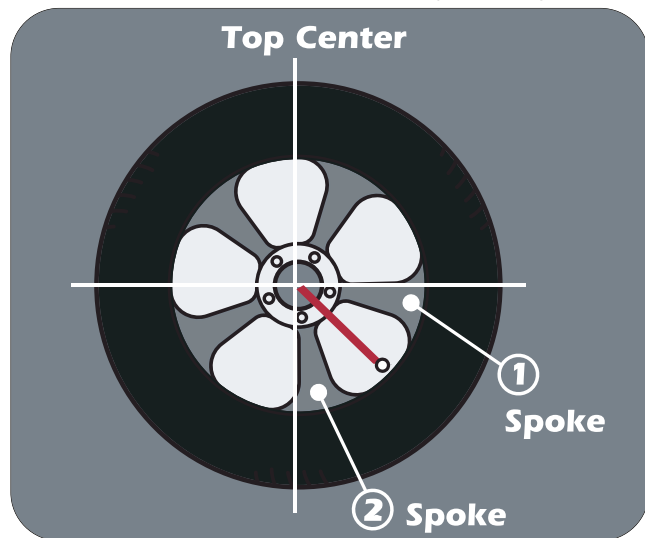

Figure 15 - Spoke 1 And Spoke 2 Locations On Either Side Of Original Outboard (Right Plane) Weight Location

6. Center and attach the spoke 2 outboard (right plane) corrective weight at the laser locator dot location (see figure 11 page 6).

7. Next, rotate the wheel toward the spoke 1 location until the outboard (right plane) center bar stops blinking and the two bars on either side blink.

Note: The laser locator dot will stop blinking.

8. Center and attach the spoke 1 outboard (right plane) corrective weight at the laser locator dot location (see figure 11 page 6).

9. Respin tire/wheel to check balance.

Patch Weight Balance - Use a static patch weight balance when there is a very large unbalance in a tire assembly or if a very large tire has a large unbalance. A weighted balance pad (patch weight) is placed inside the tire in the center to compensate for the large unbalance.

Direct Select Weight position **Patch Static** (weight location illuminates). At this location place the corrective weight amount at top-dead-center.

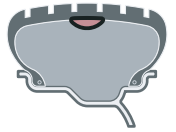

Have the following items handy: measuring tape and various patch weight sizes.

Note: Before proceeding with Patch Weight Balance, it is recommended that you use the Match Balance (Optimization) procedure first, see page 16, in order to use the smallest patch weight.



The Patch Weight Balance involves the loosening of tire beads and the inflation of a tire. Training is necessary in tire changer operation and understanding the dangers involved during bead seating and tire inflation before attempting this stage of the Patch Weight Balance procedure. Read the operators manual supplied with the tire changer and consult a supervisor.

The patch weight balance steps are as follows:

1. Direct Select Weight position PATCH STATIC. The balancer automatically sets itself for a STATIC balance.

2. Measure the outside tire diameter, see figure 16, and enter this diameter manually using the keypad.

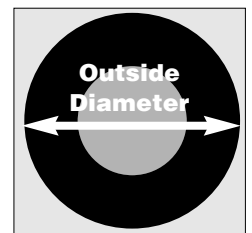

Figure 16 - Measure Outside Tire Diameter

3. Spin the wheel.

4. Rotate the wheel until the center weight position bar is blinks. Next, mark the tire and rim at 12 o'clock. Then remove the wheel assembly from the machine.

5. Disassemble the tire and rim. Place patch weight in the tire at location marked on the tire. Reassemble tire and rim matching the marks on the tire and rim.

6. Complete by balancing the wheel assembly following normal procedures.

Mounting Wheel on Spindle Shaft



Avoid back injury, seek assistance when lifting heavy tire/rim assemblies onto the balancer shaft.

Select the most appropriate mounting method for the wheel you are balancing. Using the proper method ensures secure mounting and safe balancer operation, and prevents damage to the wheel.

On most wheels, the inner side of the wheel hub usually has the most uniform surface for wheel balancing. Always center the wheel by the most uniform shaped side of the hub to achieve the most accurate balance.

Regardless of mounting type, always make sure that the wheel is forced firmly against the shaft faceplate and that the hub nut engages the threaded shaft for at least four complete turns. To assist in centering the wheel properly, rotate the wheel and the shaft while tightening the hub nut.

Standard Back Cone Mounting

Most original equipment and steel wheels can be mounted properly using this method. The wheel is centered on a cone from the inner side of the hub.

- 1.** Place the cone spring onto the shaft with the large end towards the faceplate.
- 2.** Select the cone that best fits the center hole in the wheel. Slide the cone onto the shaft with the large end towards the cone spring.
- 3.** Lift the wheel onto the shaft and center it on the cone.
- 4.** Attach the pressure cup to the hub nut and install the assembly onto the shaft. Tighten securely.

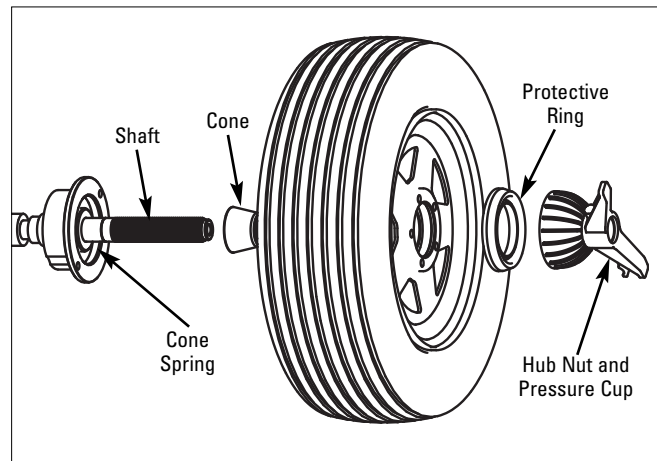

Figure 17 - Back Cone Mounting

Standard Front Cone Mounting

A wheel should be centered by the outer side of the hub only when the inner surface will not provide an accurate surface to center on.

- 1.** Select the cone that best fits the center hole in the wheel.
- 2.** Lift the wheel onto the shaft and slide it back against the shaft faceplate.
- 3.** Slide the cone onto the shaft and into the center of the wheel. You will need to lift the tire to seat the cone in the center hole.
- 4.** Install the hub nut (without pressure cup) onto the shaft. Tighten it securely against the cone.

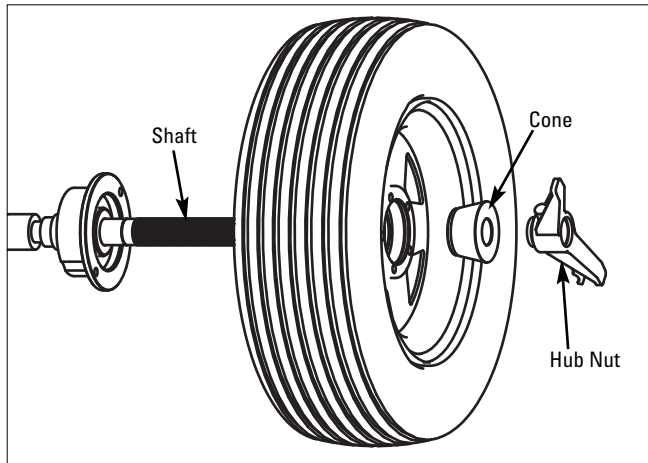

Figure 18 - Front Cone Mounting

Alternate Mounting

If the wheel has a protruding outer hub which will not permit the use of the pressure cup, or the cup will not permit the hub nut to engage at least four turns of the shaft, this alternate method should be used.

- 1.** Place the cone spring onto the shaft with the large end towards the faceplate.
- 2.** Select the cone that best fits the center hole in the wheel. Slide the cone onto the shaft with the large end towards the cone spring.
- 3.** Lift the wheel onto the shaft and center it on the cone.
- 4.** Use the small nylon spacer (no-mar ring) or a centering cone to press against the outer wheel hub.
- 5.** Install the hub nut (without the pressure cup) onto the shaft. Tighten securely.

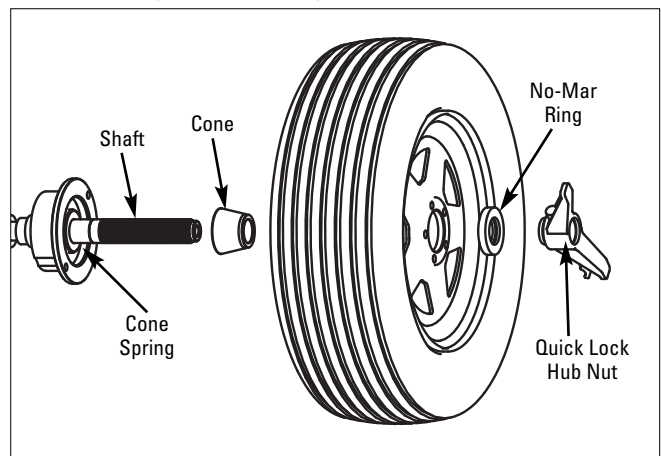

Figure 19 - Alternate Mounting

Match Balance (Optimization)

The Match Balance (Tire/Rim Weight Optimization) procedure is used to determine the best mating of tire and rim that will result in the least amount of total unbalance of the assembly. It requires two spins and two rotations of the tire on the rim. Match Balance may be needed when:

- The customer complains of ride problems.
- The balancer calls for Total Static weights in excess of 3 ounces (85 grams) on passenger car tires.

Note: A high unbalance may indicate the improper mounting of the assembly on the balancer, or a rim that is out of round or misformed, or a tire with a bubble or other problem. If the unbalance is excessive, it may be prudent to replace the rim, the tire, or both. If either is replaced, do not continue with Match Balance. Balance the new tire and rim and evaluate the readings.

Match Balance Mode

If you choose to use Match Balance to correct for a condition, such as a large static unbalance, then **follow the information box instructions for the MATCH BALANCE procedure as outlined in the following steps.**

Note: Use this procedure only after the wheel has spun and the corrective weight amount is displayed.

Note: Use the total static display option. See BALANCE OPTIONS, page 11, for further details.

- 1.** Press and hold the SHIFT key and press 5 to select the Match Balance mode. A "1" will appear in the outboard (right plane) weight display.
- 2.** Raise the hood and rotate the wheel until the valve stem is at top-dead-center. Mark the tire sidewall at the valve stem.
- 3.** Press 1 on the control panel; a "2" will appear in the outboard (right plane) weight display.
- 4.** Remove the wheel assembly from the balancer.



The Match Balance involves the loosening of tire beads and the inflation of a tire. Training is necessary in tire changer operation and understanding the dangers involved during bead seating and tire inflation before attempting this stage of the Match Balance procedure. Read the operators manual supplied with the tire changer and consult a supervisor.

5. Using a tire changer, rotate the tire 180 degrees on the rim.

6. Remount wheel assembly on the balancer. Press 2 on the control panel; a "3" will appear in the outboard (right plane) weight display.

7. Lower the hood and press START. The wheel spins.

8. When the wheel stops spinning, raise the hood and rotate the wheel until the valve stem is at top-dead-center.

9. Press 4 on the control panel.

Weight amounts appear on the control panel. The amount in the inboard (left plane) weight display is the weight imbalance for the rim. The amount in the outboard (right plane) weight display is the weight imbalance for the tire. Use these weight amounts to determine the suitability of the rim or tire.

Note: If either the rim or the tire weight amount is close to zero or zero then using Match Balance will not affect the total unbalance of the assembly.

10. Rotate the wheel until the right weight position bar flashes. Mark the tire at top-dead-center.

11. Remove wheel assembly from balancer.



The Match Balance involves the loosening of tire beads and the inflation of a tire. Training is necessary in tire changer operation and understanding the dangers involved during bead seating and tire inflation before attempting this stage of the Match Balance procedure. Read the operators manual supplied with the tire changer and consult a supervisor.

12. Using a tire changer, rotate the tire until the mark is aligned with the valve stem.

13. Remount the wheel assembly on the balancer.

14. Press NEXT or START to exit Match Balance. Select a balancing mode and balance the wheel assembly.

Machine Calibration

Calibration

1. Mount a 16-inch steel tire/wheel assembly on the balancer. A balanced tire/wheel is required.

Note: Position wheel so that no weights are on either flange at the top-dead-center location. Turn the machine OFF then ON.

2. Press and hold the SHIFT key and press 1 to select the CAL MACHINE mode.

3. Enter the D dimension.

Important: Starting with software revision 2016, the user is only required to enter the D dimension. Note that prior software versions still require that the user enter all the DIMS (A, W, and D wheel dimensions).

4. Lower the hood and press START.

5. After spin, raise the hood. Rotate wheel until the outboard (right plane) center bar blinks; attach calibration weight to the outside flange at top-dead-center.

Note: Use a 4-ounce calibration weight in ounce mode or a 100-gram calibration weight in gram mode.

Important: Starting with software revision 2019, the factory default is set for a 4-ounce calibration weight amount for both the ounce and the gram weight measurement modes. Therefore, for machine calibration, only the 4-ounce calibration weight is necessary regardless of the weight measurement mode setting.

To use a 100-gram calibration weight amount, when first prompted to use the 4-ounce weight in calibration mode, press the gram/oz key (SHIFT 9) to toggle from 4.00 to 100. Once set, the balancer retains this new default preference in memory.



Figure 19 - Calibration Weight On Outside Flange At Top-Dead-Center

6. Lower the hood and press START.

Important: It is critical that the inner weight be placed accurately to achieve proper calibration. If the calibration weight is not moved from the outside flange directly across to the inside flange an inner weight placement error will occur. To correct, follow the information box instructions.

7. After spin, raise the hood. Rotate wheel until the inboard (left plane) center bar blinks; move and attach the calibration weight to the inside flange at top-dead-center.

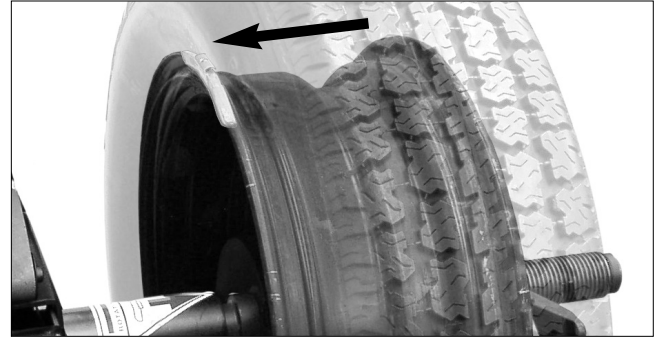

Figure 20 - Calibration Weight Moved (Directly Across) To Inside Flange

8. Lower the hood and press START.

9. Calibration complete. Press NEXT.

Maintenance Instructions

The balancer requires only minor maintenance to keep the unit operating properly.

1. Keep the display clean and clear. Use a damp cloth. Do not use cleaners or solvents which leave oily or filmy residues behind.

2. Keep the adapters, cones, faceplate, threaded shaft, pressure cup, and hub nut clean. Grease and dirt buildup will cause inaccurate balancing and premature wear. Clean these items at least once a day with a vaporizing solvent.

3. Clean weight tray and any accessory posts, pegs, or storage shelves with a vaporizing solvent. Weights stored in a dirty tray may pick up grease and dirt which may keep them from securely attaching to the wheel.



Use common sense, this is an electrical device. Exposing the balancer to water, either by hose or bucket, or by exposure to rain or snow, may cause risk of shock or electrocution to operator or bystanders. Place, store, and operate the balancer only in a dry, sheltered location.



Do not hose down with water or bucket wash the balancer. Extensive damage to the balancer will result. Sensitive electronic components, wiring harnesses, and other devices housed in the balancer are not intended to be exposed to water.

4. Keep the area around the balancer clear. Remove any tools or other items that are leaning against the balancer. Keep the area under the balancer clear. Remove any items that may cause the balancer to not sit level. Be particularly cautious of new or used wheel weights on the floor, as they may cause personal injury due to falls.

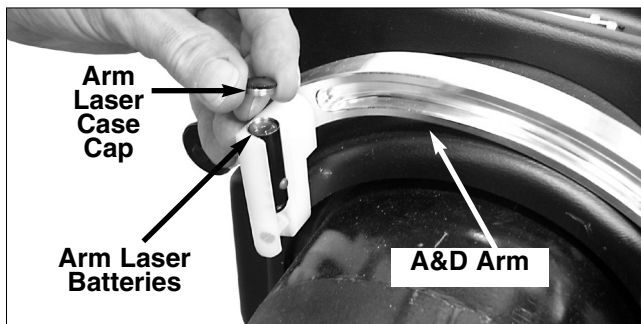

5. To replace Arm Laser battery, remove cap. Discard old batteries. Install two new batteries, plus side up. Replace cap.

6. Use only a lithium battery when replacing the battery located on the processor board.



Risk of explosion if battery is replaced by an incorrect type. Dispose of used batteries according to the instructions.

7. Use only COATS® accessories. Accessories from other manufacturers may not fit or function properly, and may damage the balancer.

Diagnostic Procedures

After Balance Vibration Problems

If vibration is still present after balancing the wheels and driving the vehicle on smooth pavement, remove the wheels and recheck the balance. If a wheel is out of balance the cause may be:

- Wheel was not mounted/centered correctly on the balancer.
- A weight has come off the wheel (possibly the wrong clip style). Remove the other weights from the wheel and rebalance.
- Foreign material inside the tire. Remove the tire from the wheel, remove the foreign material, and remount. Remove wheel weights and rebalance the wheel.
- Stones or other foreign objects caught in the tire tread or rim. Remove the objects. Check and rebalance if needed.

If the balancer still indicates the wheels are balanced to within 0.05 ounces on both inner and outer displays, the problem is not in the balance of the wheels. Check the following possible sources of vibration:

- Tire pressure. Bring all tires up to the recommended PSI.
- Radial or lateral runout in the tire or wheel. Replace the damaged part.
- Unbalance in wheel covers or trim rings. Remove the wheel covers or trim rings and test drive. If the vibration is gone, remove the shaft and use an appropriate adapter to mount the wheel to the balancer. Balance the wheel with the wheel cover or trim ring attached to the wheel.
- Incorrectly mounted wheel. Remount correctly.
- Damaged wheel bolt holes. Replace wheel.
- Worn universal joints. Replace as required.
- Drive shaft unbalance or damaged. Balance, repair, or replace.
- Unbalance in brake rotor(s) or drum(s).
- Suspension out of alignment. Align the vehicle and replace any damaged or worn parts.

Troubleshooting

A COATS® Service Technician may ask for information to help diagnose service concerns (Please contact COATS® directly at 1-800-688-9240 for the Certified Service Partner nearest you). Conveying this information to your service technician prior to servicing can help to expedite service to your equipment. Although much of the diagnostic information aids your COATS® Service Technician, several remedies for balancer misfunctions are available to the operator.

Error Messages - One of the following error messages, shown in the information box display, may appear indicating a problem with the balancer.

Note: Always EXIT error message and repeat function to see if error is eliminated.

Error 1 - Spin up is too slow - Verify power supply to balancer and motor connection E1

Error 2 - Spin up time too long - Check Wheel DIA and power supply - press STOP - EXIT E2

Error 3 - No rotation signal - Check motor & encoder function & wiring -press STOP - EXIT E3

Error 4 - Wheel rotation direction is reversed - Disconnect power and correct wiring E4

Error 5 - Stop time too long - Verify power supply and motor connection - press STOP - EXIT E5

Error 6 - Encoder is not connected or has failed - Disconnect power supply and repair E6

Error 9 - Wheel coast speed is too slow E9

Error 24 - Lower hood to spin E24

Error 25 - Loose hub nut. Tighten hub nut and respin E25

Error 26 - CAL ERROR E26

Overload Protection - On units manufactured after August 2007, the balancer's motor is overload protected per UL requirements. After 4 to 5 minutes the machine automatically resets itself; activating the fan motor. If this happens, notify your Certified Service Partner immediately.

Important: Allow the fan to cool the motor for at least 30 minutes before using the balancer so the overload protection is not tripped again.

Installation Instructions

Receiving

The shipment should be thoroughly inspected as soon as it is received. The signed bill of lading is acknowledgement, for the carrier, of receipt in good condition of the shipment covered by our invoice.

If any of the goods called for on this bill of lading are shorted or damaged, do not accept them until the carrier makes a notation of the shorted or damaged goods on the freight bill. Do this for your own protection.

NOTIFY THE CARRIER AT ONCE if any hidden loss or damage is discovered after receipt and request him to make an inspection. If the carrier will not do so, prepare an affidavit to the effect that you have so notified the carrier (on a certain date) and that he has failed to comply with your request.

IT IS DIFFICULT TO COLLECT FOR LOSS OR DAMAGE AFTER YOU HAVE GIVEN THE CARRIER A CLEAR RECEIPT.

File your claim with the carrier promptly. Support your claim with copies of the bill of lading, freight bill, invoice, and photographs, if possible.

Although COATS responsibility ceases upon delivery of the shipment to the carrier, we will gladly assist in tracing lost shipments. Our willingness to assist in every possible manner does not make COATS responsible for collection of claims, or replacement of lost or damaged materials.

Electrical Requirements

See serial tag for the appropriate power requirements of your machine.

Always have a qualified electrician install the proper receptacles in accordance with state and local codes.

Setup



Do not use the control panel, control panel base, accessory storage, faceplate, hood or shaft to lift the balancer.



Do not attempt to install and setup the unit yourself. Contact COATS® as noted below.

A factory trained COATS® Service Technician must perform the install, setup, and initial test procedures on your wheel balancer. Do not attempt to install and setup the unit yourself. Accurate and reliable operation of your unit depends on proper installation. Please contact COATS® directly at 1-800-688-9240 for the Certified Service Partner nearest you.

Connect to Power

Your factory trained COATS® Service Technician should do the final check to verify the power installation before connecting the balancer to a power supply. Failure due to improper power connection may void the warranty.

Floor and Space Requirements

The balancer must be located on a flat floor of solid construction, preferably concrete. The balancer must sit solidly on its three feet. If the balancer is not level, does not sit solidly on its three feet, or is placed on an unstable floor, the balancer will not function properly and may produce inaccurate balance readings.

Do not operate the balancer while it is on the pallet.

Select a location for the balancer that provides a level, solid floor, and adequate clearance around and above the balancer. Make sure the location selected has enough room above and behind the unit so the hood can be raised completely. The location must also provide working room for mounting and removing wheels. Make sure the area has adequate lighting.

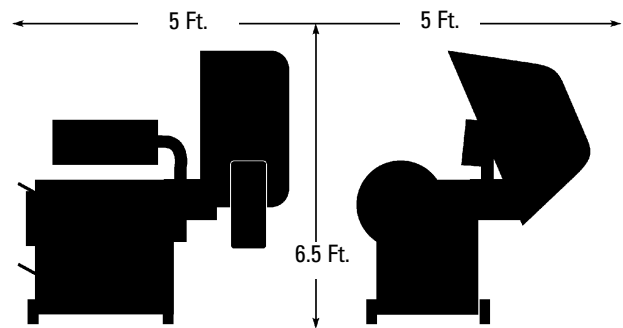

Figure 21 - Space Requirements

Specifications

Balancing Modes

8

Wheel Diameter Range

8 - 30 inches

Wheel Width Range

2 - 20 inches

Maximum Outside Tire Diameter

Up to 44 inches

Maximum Tire/Wheel Weight

160 pounds (68 Kg)

Mounting Shaft Diameter

User choice of 28mm or 40mm

Resolution (Round Off Mode)

0.25 ounce, position 1.40 degrees

Resolution (Non-Round Off Mode)

0.01 ounce, position 1.40 degrees

Balancing Display Increments

0.25 or 0.01 ounces

Electrical Requirements

220 V, 1 Ph, 60 Hz

220V, 3Ph

440V, 3Ph

(use grounding type plug)

Footprint

60 inches x 60 inches

Shipping Weight

680 pounds (308 Kg)

Features

- Automatic Data Entry for Offset and Diameter - Manual Entry Backup on all Parameters
- Static-on-Screen™
- Four Fixed Function Keys, Seven Program Keys for user Friendly Operation
- Balancing Modes
 - Dynamic (Standard): Clip-on Weights
 - Alloy: User Defined
 - Static
 - Patch (Tire Weight): Static Only
 - Behind the Spoke Weight Placement (All Modes with Inside Wheel Weights)
- Auto Start When Hood is Lowered
- Single Spin Balancing - Dynamic and Static
- Easy-To-Read Position Indicators
- Laser Guided Operation™ Tape-A-Weight™ Placement with Offset Arm
- Hood Safety Interlock System
- Extended Mounting Faceplate for Deeper Wheels
- Removable Center Shaft for Closed Center Wheels
- Match Balance (Optimization)
- Operator Memory for Two Different Users
- User Friendly Weight and Position Calibration
- No Bolt-down Installation
- Solid State Motor Control
- UL/CSA Listing

Accessory Options

<i>Contents</i>	<i>Part Number</i>	
Basic Kit	8114335 (28mm)	8114339 (40mm)
Small Cone		
Medium Cone		
Large Cone		
Light Truck Back Cone		
Rim Width Calipers		
Wheel Weight Pliers		
Hubnut		
Small Pressure Cup & Rubber Lip		
Cone Spring		
Stub Shaft		
Extended Kit	8114337 (28mm)	8114341 (40mm)
Basic Kit		
Short Cone		
Light Cone Kit		
Faceplate Extension		
Premium Kit	8114338 (28mm)	8114342 (40mm)
Extended Kit		
Pin Plate System		
Balancer Mate Storage Rack		

