

# BASELINE™

## Wheel Balancers



Model 350 Shown



Model 550 Shown

## Parts Identification

**READ** these instructions before placing unit in service. **KEEP** these and other materials delivered with the unit in a binder near the machine for ease of reference by supervisors and operators.

## ***Parts Identification***

The following pages include parts breakdowns with exploded view illustrations to help with ordering replacement or spare kits. Assemblies are noted where it is recommended that individual parts not be ordered separately. Note that the parts view illustrations are for multiple models and not all parts shown are on all models. Every effort is made to supply accurate exploded views, however, due to interim changes in manufacturing operations, some units may not be exactly as illustrated.

## ***Table of Contents***

<b>Parts Identification .....</b>	<b>2</b>
<b>Chassis &amp; Touch Panel Assemblies .....</b>	<b>4</b>
<b>Spindle Shaft Assembly.....</b>	<b>5</b>
<b>Distance Gauge Assembly.....</b>	<b>6</b>
<b>Power Panel Assembly.....</b>	<b>7</b>
<b>Wheel Guard Assembly .....</b>	<b>7</b>

*Rim Clamp® is a registered trademark owned by Hennessy Industries, Inc.*

*Baseline™ is a trademark owned by Hennessy Industries, Inc.*

## Chassis & Touch Panel Assemblies

Item No	Part No.	Description
1	886SC82916	Computer Board - 350
	886SCB82910	Computer Board - 550
2		Chassis
3	814FB81408	Pin Kit
4	8511242101	Switch
5	846PRB8827	Control Panel - 350
	846PRB8833	Control Panel - 550
6	814FB72050	Cover with Weight Tray

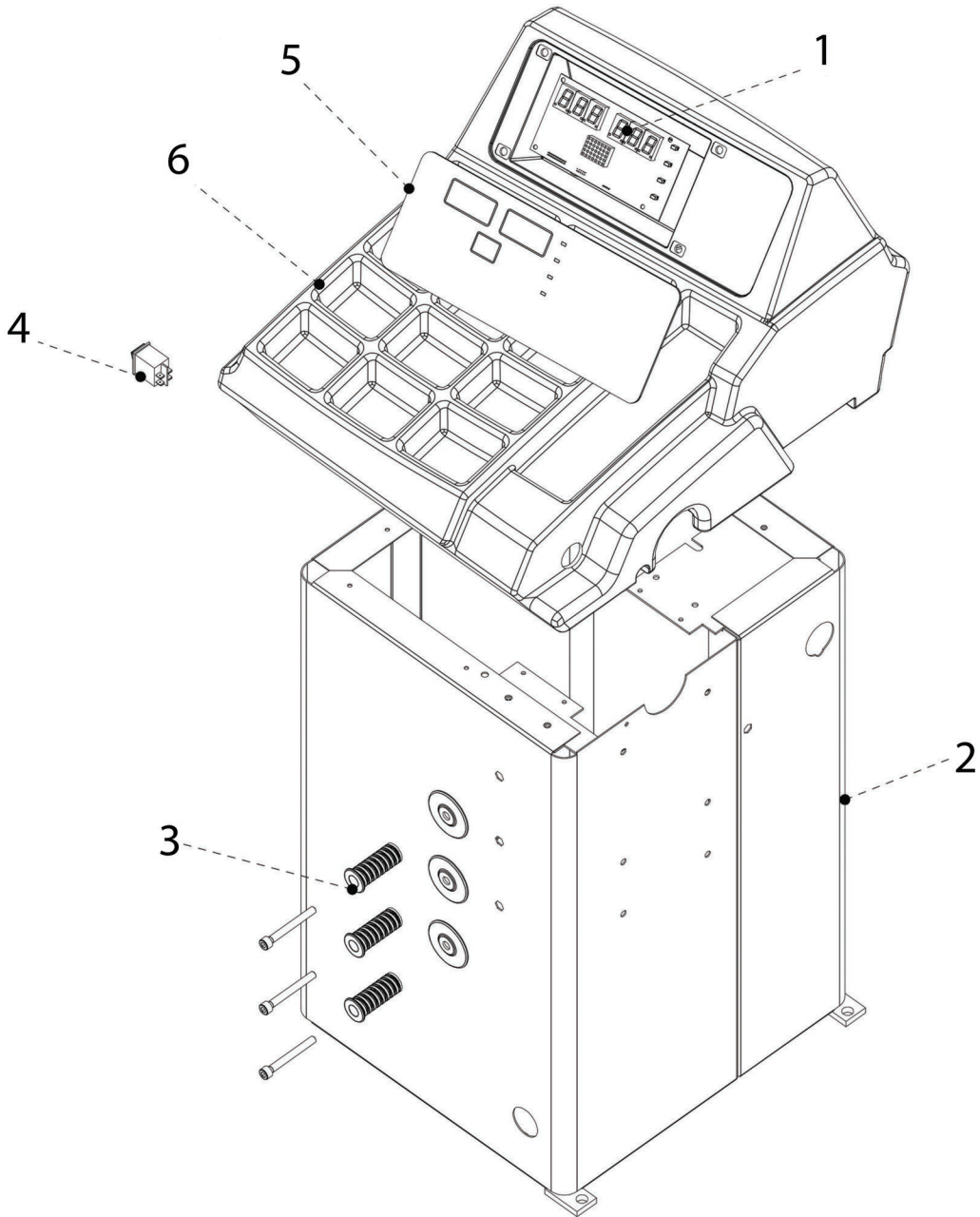

# Spindle Shaft Assembly

Item No	Part No.	Description
1	842FM79956	Stub Shaft, 40 mm
2	84RFM86798	Piezo Assembly
3	84RFM83650	Spindle
4	8080048008	Belt - 8 Ribs
5	84RSD86802	Position Encoder
6	85RFGA5434	Capacitor + Motor, 115V
	85008913	Motor 115V
	8568003558	Capacitor 115V
	85RFGA5435	Capacitor + Motor, 230V
	8568001058	Capacitor 230V
7	84RFMB9525	Spindle Shaft, 115V
	84RFMB9524	Spindle Shaft, 230V

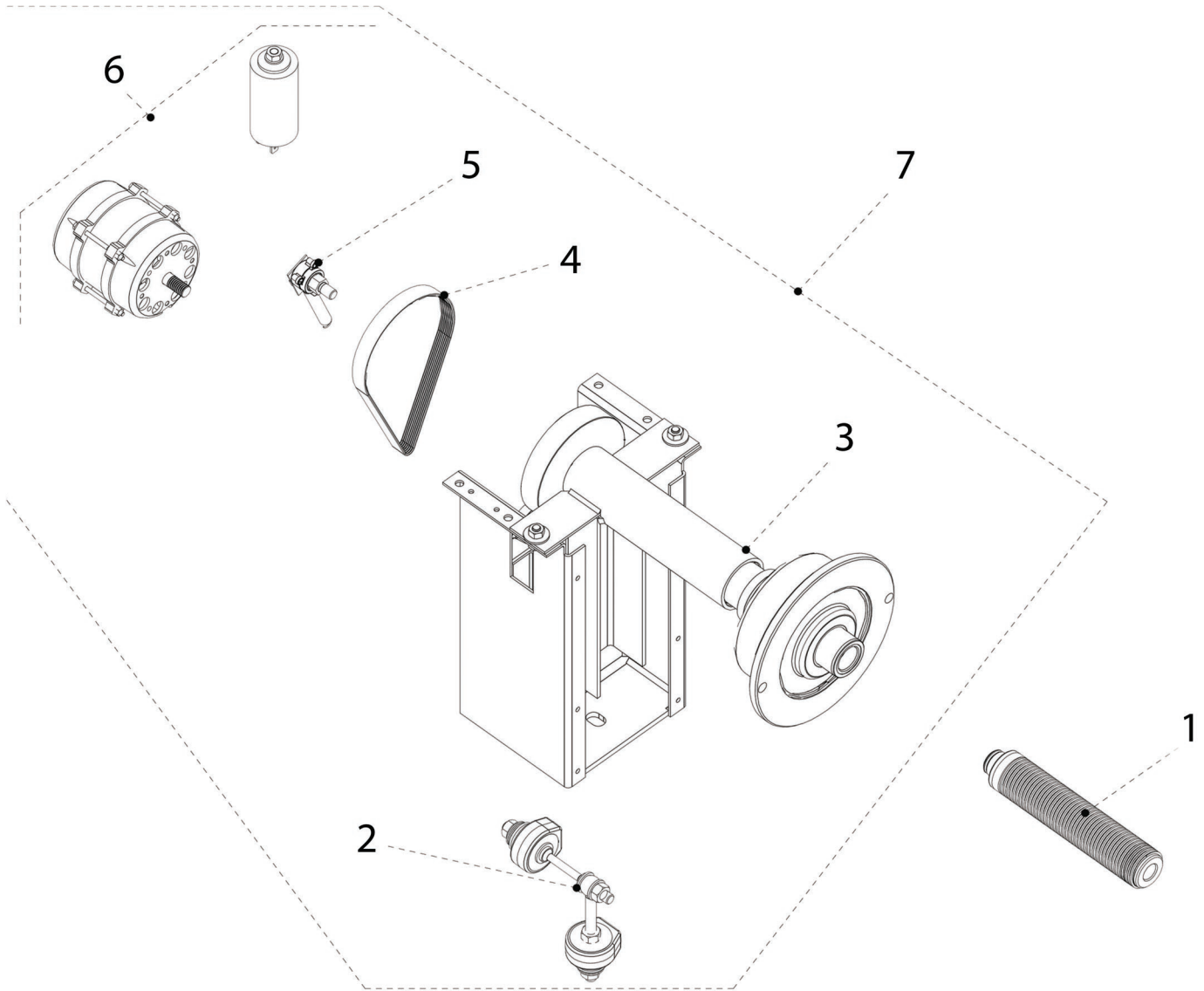

# Distance Gauge Assembly

**Model 350**

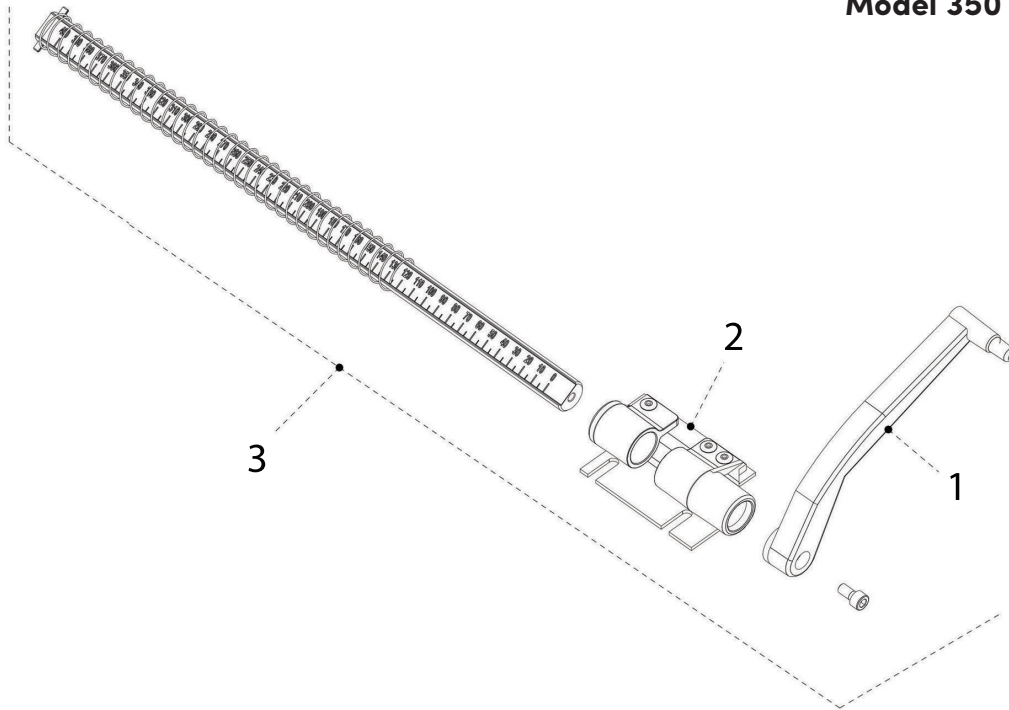

Item No	Part No.	Description
1	821FC47315	Manual Offset Arm - 350
	846FC61931	Manual Offset Arm - 550
2	846FC84169	Offset Arm Bracket
3	846FC82160	Offset Arm Complete -350
	886FC82244	Offset Arm Complete -550
4	886SB82328	Potentiometer - 550

**Model 550**

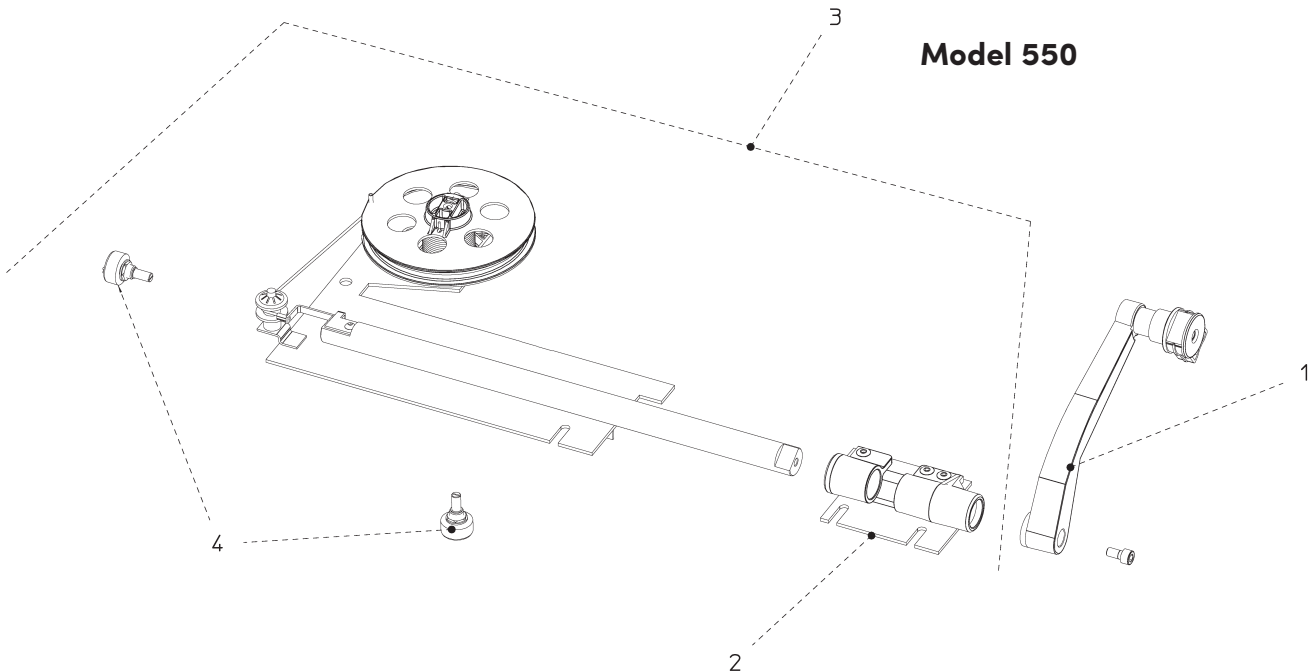

## Power Panel Assembly

Item No	Part No.	Description
1	8511242101	Switch
2	8568003558	Capacitor - 115V
	8568001058	Capacitor - 10mf - 230V
3	867M94502F	Power Board - 115V
	867M94502E	Power Board - 230V

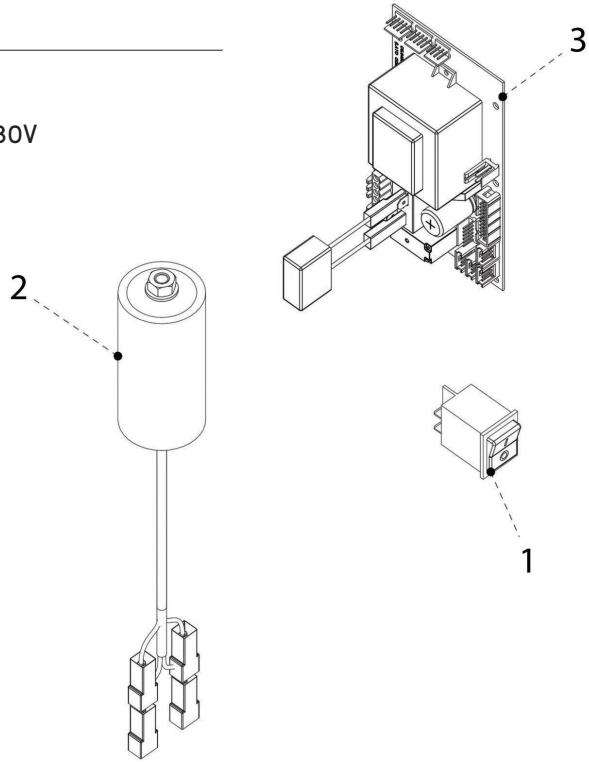

## Wheel Guard Assembly

Item No	Part No.	Description
1	814FW54110	Wheel Guard
2	842XX71013	Tube Chassis
3	842FW81965	Mounting Tube
4	886SB96666	Micro Switch
5	814FW70362	Ring
6	894FW81956	Wheel Guard Assembly

