

# BASELINE™

## Wheel Balancers



Model 350 Shown



Model 550 Shown

See  
★ **Balancing**  
**Your First Tire**  
on page 7.

***Safety Instructions***  
***Set Up Instructions***  
***Operation Instructions***  
***Maintenance Instructions***

**READ** these instructions before placing unit in service. **KEEP** these and other materials delivered with the unit in a binder near the machine for ease of reference by supervisors and operators.

# Table of Contents

**IMPORTANT SAFETY INSTRUCTIONS** ..... 1

**Safety Instructions** .....2

Owner’s Responsibility ..... 2

Operator Protective Equipment ..... 2

Definitions of Hazard Levels ..... 2

Safety Notices and Decals..... 3

**Set Up Instructions** .....4

Receiving .....4

Electrical Requirements ..... 4

Floor and Space Requirements.....5

Machine Set Up ..... 6

Connect to Power ..... 6

Initial Testing ..... 6

Wheel Guard Installation..... 6

**Specifications** .....8

**Features** .....8

**★Balancing Your First Tire**.....9

**Principal Operating Parts**..... 10

Know Your Unit.....11

Power Switch .....11

**Operating the Balancer** .....12

Wheel Mounting .....12

Standard Back Cone Mounting .....12

Standard Front Cone Mounting .....13

Control Panels.....14

Operation Functions Menu .....16

Correction Modes.....17

Manual Presetting of Wheel  
Dimensions - Model 350 .....18

Measurement Result - Model 350 .....19

Spilt Function  
(unbalance resolution) - Model 350.....19

Unbalance Optimization - Model 350 .....20

Presetting of Wheel Dimensions - Model 550.....21

Measurement Result - Model 550..... 22

Unbalance Unit of Measure - Model 550..... 22

Static Unbalance - Model 550..... 22



Exact Positioning Of The Adhesive Weight By Means  
Of The Gauge With Clips - Model 550..... 22

Spilt Function  
(unbalance resolution) - Model 550..... 23

**Maintenance Instructions** .....24

**Diagnostic Procedures** .....25

Self Diagnostics ..... 25

Machine Calibration ..... 25

After Balance Vibration Problems ..... 26

*BADA® is a registered trademark owned by  
Hennessy Industries, Inc.*

*Baseline™ and Tape-A-Weight™ are trademarks  
owned by Hennessy Industries, Inc.*

## **IMPORTANT SAFETY INSTRUCTIONS**

### **READ ALL INSTRUCTIONS**

1. Eye and face protection recommendations:  
“Protective eye and face equipment is required to be used where there is a reasonable probability of injury that can be prevented by the use of such equipment.” O.S.H.A. 1910.133(a) Protective goggles, safety glasses, or a face shield must be provided by the owner and worn by the operator of the equipment. Care should be taken to see that all eye and face safety precautions are followed by the operator. **ALWAYS WEAR SAFETY GLASSES.** Everyday glasses only have impact resistant lenses, they are not safety glasses.
2. Do not disable hood safety interlock system, or in any way shortcut safety controls and operations.
3. Be sure that wheels are mounted properly, the hub nut engages the arbor for not less than four (4) turns, and the hub nut is firmly tightened before spinning the wheel.
4. Read and understand this manual before operating. Abuse and misuse will shorten the functional life.
5. Be sure the balancer is properly connected to the power supply and electrically grounded.
6. Do not operate equipment with a damaged cord or if the equipment has been dropped or damaged – until it has been examined and repaired by a qualified serviceman.
7. Do not let cord hang over edge of table, bench, or counter or come in contact with hot manifolds or moving fan blades.
8. If an extension cord is necessary, a cord with a current rating equal to or more than that of the equipment should be used. Cords rated for less current than the equipment may overheat. Care should be taken to arrange the cord so that it will not be tripped over or pulled.
9. Keep guards and safety features in place and in working order.
10. Wear proper clothing. Safety toe, non-slip footwear and protective hair covering to contain hair is recommended. Do not wear jewelry, loose clothing, neckties, or gloves when operating the balancer.
11. Keep work area clean and well lighted. Cluttered and/or dark areas invite accidents.
12. Avoid dangerous environments. Do not use power tools or electrical equipment in damp or wet locations, or expose them to rain.
13. Avoid unintentional starting. Be sure the balancer is turned off and power disconnected before servicing.
14. Disconnect the balancer before servicing.
15. Use only manufacturer’s recommended accessories. Improper accessories may result in personal injury or property damage.
16. Repair or replace any part that is damaged or worn and that may cause unsafe balancer operation. Do not operate damaged equipment until it has been examined by a qualified service technician.
17. Never overload or stand on the weight tray or any part of the balancer.
18. Do not allow untrained persons to operate machinery.
19. To reduce the risk of fire, do not operate equipment in the vicinity of open containers or flammable liquids (gasoline).
20. Adequate ventilation should be provided when working on or operating internal combustion engines.
21. Keep hair, loose clothing, fingers, and all parts of body away from moving parts.
22. Use equipment only as described in this manual.
23. Use only manufacturer’s recommended attachments and accessories.

**SAVE THESE INSTRUCTIONS**

# Safety Instructions

## Owner's Responsibility

To maintain machine and user safety, the responsibility of the owner is to read and follow these instructions:

- Follow all installation instructions.
- Make sure installation conforms to all applicable Local, State, and Federal Codes, Rules, and Regulations; such as State and Federal OSHA Regulations and Electrical Codes.
- Carefully check the unit for correct initial function.
- Read and follow the safety instructions. Keep them readily available for machine operators.
- Make certain all operators are properly trained, know how to safely and correctly operate the unit, and are properly supervised.
- Allow unit operation only with all parts in place and operating safely.
- Carefully inspect the unit on a regular basis and perform all maintenance as required.
- Service and maintain the unit only with authorized or approved replacement parts.
- Keep all instructions permanently with the unit and all decals/labels/notices on the unit clean and visible.
- Do not override safety features.

## Operator Protective Equipment

Personal protective equipment helps make tire servicing safer. However, equipment does not take the place of safe operating practices. Always wear durable work clothing during tire service activity. Loose fitting clothing should be avoided. Tight fitting leather gloves are recommended to protect operator's hands when handling worn tires and wheels. Sturdy leather work shoes with steel toes and oil resistant soles should be used by tire service personnel to help prevent injury in typical shop activities. Eye protection is essential during tire service activity. Safety glasses with side shields, goggles, or face shields are acceptable. Back belts provide support during lifting activities and are also helpful in providing operator protection. Consideration should also be given to the use of hearing protection if tire service activity is performed in an enclosed area, or if noise levels are high.

## Definitions of Hazard Levels

Identify the hazard levels used in this manual with the following definitions and signal words:

### DANGER

Watch for this symbol:



It Means: Immediate hazards, which will result in severe personal injury or death.

### WARNING

Watch for this symbol:



It Means: Hazards or unsafe practices, which could result in severe personal injury or death.

### CAUTION

Watch for this symbol:



It Means: Hazards or unsafe practices, which may result in minor personal injury or product or property damage.



Watch for this symbol! It means BE ALERT! Your safety, or the safety of others, is involved!

## Safety Notices and Decals



Failure to follow danger, warning, and caution instructions may lead to serious personal injury or death to operator or bystander or damage to property. Do not operate this machine until you read and understand all the dangers, warnings and cautions in this manual. For additional copies of either, or further information, contact:

Hennessy Industries, Inc.  
1601 JP Hennessy Drive  
LaVergne, TN 37086  
(615) 641-7533 or (800) 688-6359  
www.baselinegarage.com



Never raise up the wheel guard before the wheel has come to a stop. Keep hair, loose clothing, fingers and all parts of body away from moving parts.

- STOP key for stopping the wheel under emergency conditions.
- A hood guard of high impact plastic that is designed to prevent the counterweights from flying out in any direction except towards the floor.

 <b>WARNING</b>	 <b>AVERTISSEMENT</b>
<p><b>RISK OF EXPLOSION</b></p> <p>This equipment has internal arcing or sparking parts which should not be exposed to flammable vapors. Do not locate in a recessed area or below floor level.</p> <p><b>THIS EQUIPMENT MUST BE EARTH-GROUNDED</b></p> <p>The earth-ground connector built into the power cord provides protection to reduce the risk of electrical shock.</p>	<p><b>RISQUE D'EXPLOSION</b></p> <p>Cet équipement possède des pièces internes, pouvant lancer des arcs ou jeter des étincelles, et qui ne devraient pas être exposées à des vapeurs inflammables. Ne situez pas l'équipement dans des endroits encastrés ou en-dessous du niveau du plancher.</p> <p><b>CET ÉQUIPEMENT DOIT ÊTRE MIS À LA TERRE</b></p> <p>Le raccord de mise à la terre incorporé dans le cordon de puissance fournit une protection afin de réduire le risque d'électrocution.</p>
 <b>CAUTION</b>	 <b>ATTENTION</b>
<p>Do not use below garage floor or grade level.</p> <p>Disconnect power before servicing this equipment.</p> <p>To prevent electrical shock, do not remove cover. No user serviceable parts inside. Refer servicing to qualified service personnel.</p>	<p>N'utilisez pas en-dessous du plancher du garage ou du palier.</p> <p>Débranchez le cordon de puissance avant de faire l'entretien de cet équipement.</p> <p>Afin de vous protéger contre l'électrocution, n'enlevez pas le couvercle. Aucune pièce interne ne nécessite d'entretien par l'utilisateur. Référez l'entretien à un personnel de service qualifié.</p>

8113927 05

 **WARNING**

**Maximum Size of Wheel Rating**

Weight	Diameter	Width
<b>165 lbs.</b>	<b>30 in.</b>	<b>20 in.</b>

**Maximum Duty Cycle**

**30 Wheels/Hour @ 165 lbs.**

 **AVERTISSEMENT**

**Capacité de la Dimension Maximale de la Roue**

Poids	Diamètre	Largeur
<b>75Kg</b>	<b>72,5cm</b>	<b>50,8cm</b>

**Cycle de Service Maximum**

**30 Roues/Heure @ 75Kg**

85610424 00

## ***Set Up Instructions***

### **Receiving**

The shipment should be thoroughly inspected as soon as it is received. The signed bill of lading is acknowledgement, for the carrier, of receipt in good condition of the shipment covered by our invoice.

If any of the goods called for on this bill of lading are shorted or damaged, do not accept them until the carrier makes a notation of the shorted or damaged goods on the freight bill. Do this for your own protection.

NOTIFY THE CARRIER AT ONCE if any hidden loss or damage is discovered after receipt and request him to make an inspection. If the carrier will not do so, prepare an affidavit to the effect that you have so notified the carrier (on a certain date) and that he has failed to comply with your request.

IT IS DIFFICULT TO COLLECT FOR LOSS OR DAMAGE AFTER YOU HAVE GIVEN THE CARRIER A CLEAR RECEIPT.

File your claim with the carrier promptly. Support your claim with copies of the bill of lading, freight bill, invoice, and photographs, if possible.

Although Hennessy Industries, Inc. responsibilities cease upon delivery of the shipment to the carrier, we will gladly assist in tracing lost shipments. Our willingness to assist in every possible manner does not make Hennessy Industries, Inc. responsible for collection of claims, or replacement of lost or damaged materials.

### **Electrical Requirements**

See serial tag for the appropriate power requirements of your machine.

Always have a qualified electrician install the proper receptacles in accordance with state and local codes.

## Floor and Space Requirements

The balancer must be located on a flat floor of solid construction, preferably concrete. The balancer must sit solidly on its three feet. If the balancer is not level, does not sit solidly on its three feet, or is placed on an unstable floor, the balancer will not function properly and may produce inaccurate balance readings.

Do not operate the balancer while it is on the pallet.

Select a location for the balancer that provides a level, solid floor, and adequate clearance around and above the balancer. Make sure the location selected has enough room above and behind the unit so the hood can be raised completely. The location must also provide working room for mounting and removing wheels. Make sure the area has adequate lighting.

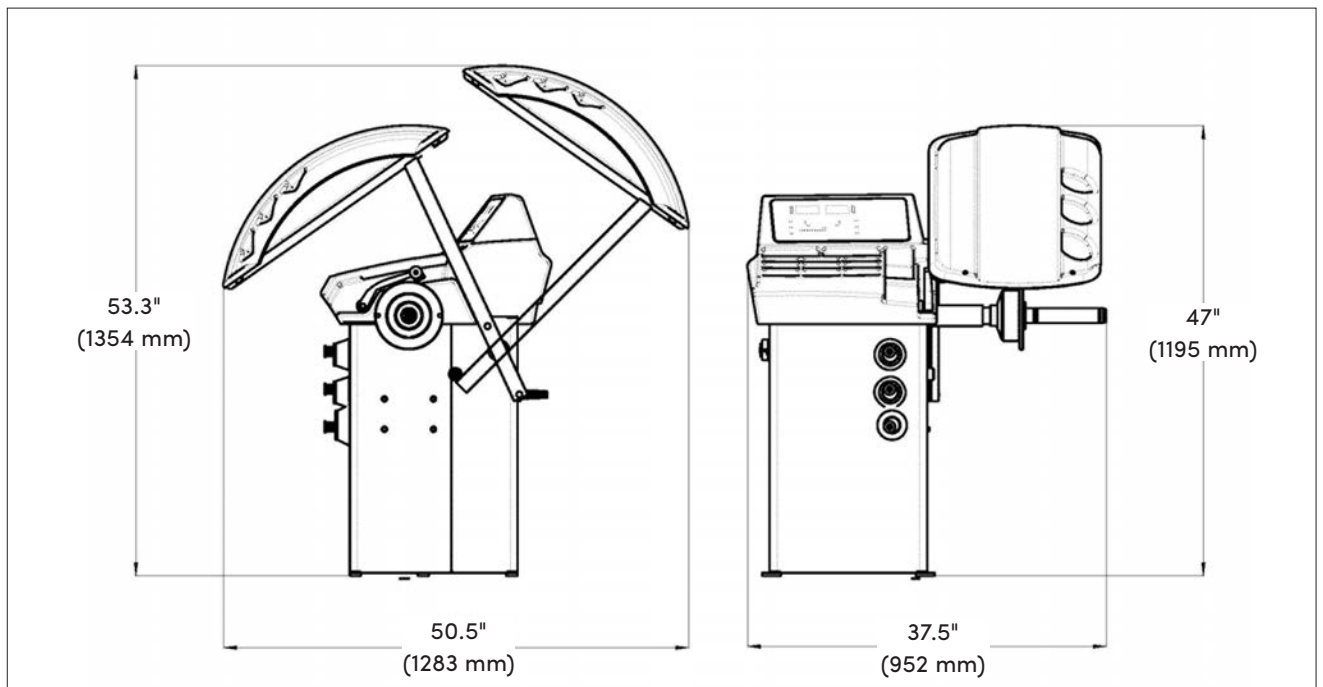

Figure 1 - Space Requirements

## Machine Set Up



**Do not use the control panel, control panel base, accessory storage, faceplate, hood or shaft to lift the balancer.**



**Use help to remove the balancer from the pallet. The unit is heavy and the weight is not evenly distributed. Dropping the unit may cause personal injury or equipment damage.**

**1.** Remove the shipping carton from the pallet. Then remove all the loose parts and accessories packed around the unit.

**2.** Remove the shipping bolts that hold the balancer to the pallet.

**3.** Lift the balancer off the pallet and place it in its operating location.

**4.** Install and tighten the threaded stub shaft into the end of the motor shaft.

### Connect to Power

Your factory trained Hennessy Industries, Inc. Service Technician should do the final check to verify the power installation before connecting the balancer to a power supply. Failure due to improper power connection may void the warranty.

### Initial Testing

**1.** Plug the unit into an appropriate power outlet. If the circuit breaker for the outlet is off, turn it on.

**2.** Turn the balancer on. The power switch is on the left side of the unit.

## Wheel Guard Installation

**1.** Install plastic bushing on end of hood tube.

**2.** Insert hood tube through hole and slide through hood mounting bracket. The bushing will only fit one way due to its molding.

**3.** Install second plastic bushing on the end of the hood tube protruding from the bracket.

**4.** Slide on the stop ring. The set screws may need to be loosened to install slide ring. Adjust the stop ring so the notch is parallel to the floor when the hood is in the down position.

**5.** Install the plug in the end of the hood tube.

**6.** Tighten the set screws to secure stop ring in place.

**7.** Raise the hood.

**8.** Screw on hood switch with two screws. The height of the switch will need to be adjusted to ensure the switch button is up when the hood is down. The switch button should fit neatly in the cutout of the stop ring.

**9.** Connect the switch wiring end to the three prong connector on the back panel of the chassis.

**10.** Test the hood switch with the auto spin feature to ensure proper installation. If problems check the height of the hood switch button for proper operation.



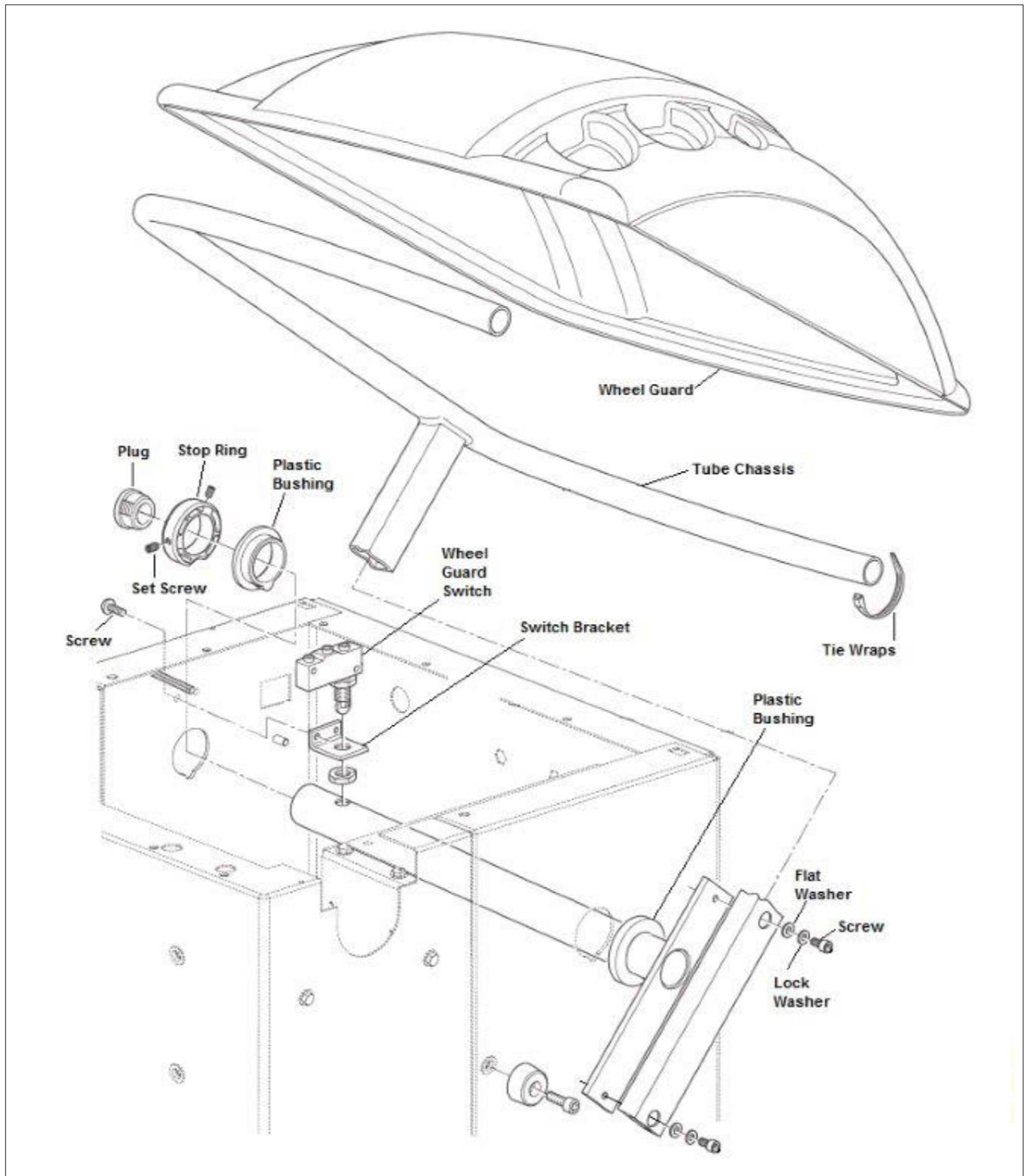

Figure 2 - Wheel Guard Assembly Diagram

## ***Specifications***

### **Wheel Diameter Range**

10 - 30 inches (25,4 - 76,2 cm)

### **Wheel Width Range**

1.5 - 20 inches (3,8 - 50,8 cm)

### **Maximum Outside Tire Diameter**

Up to 35 inches (88,9 cm)

### **Maximum Tire/Wheel Weight**

165 lbs. (75 Kg)

### **Mounting Shaft Diameter**

40 mm

### **Resolution (Round Off Mode)**

0.25 ounce, position 1.40 degrees

### **Resolution (Non-Round Off Mode)**

0.35 ounce, position 1.40 degrees

### **Balancing Display Increments**

0.25 or 0.01 ounces

### **Electrical Requirements**

115 V, 60 Hz, 15 A, 1 Ph.

230 V, 50/60 Hz, 15 A, 1 Ph.

(use grounding type plug)

### **Footprint**

50.5 x 37.5 x 53.3 inches (1283 x 952 x 1354 mm)

### **Shipping Weight**

254 pounds (115 Kg)

(without accessories)

## ***Features***

- o Auto Start Hood
- o Integrated LED Matrix
- o Automatic Distance & Diameter Entry (2D)
- o Space Saving Design
- o 40mm Shaft
- o Direct Tape-A-Weight™ Placement (

## ★ **Balancing Your First Tire**

### **1. Turn the machine OFF then ON**

(resets machine).

*Note: The machine wakes up using standard clip-on wheel weight locations (c1 & c2) and wheel dimensions.*

### **2. Mount a tire/wheel on the balancer that will use standard clip-on wheel weights.**

*Use the most appropriate mounting method.*

### **3. Always remove any weights already attached to the wheel.**

### **4. Enter A & D wheel dimensions using offset arm.**

*Automatic Measurement – pull offset arm out to the wheel, hold it still at clip-on weight position against wheel flange. Return arm to home position.*



Figure 3 -Offset Arm At Clip-On Weight Location

### **5. Enter Width wheel dimension.**

*Use plastic calipers to measure wheel width.*

*Use keypad to enter Width value.*

### **6. Lower the hood, press Start; wheel spins and unbalances are measured and displayed.**

*The corrective weight amount appears in the digital readout windows.*

### **7. Raise hood after tire stops rotating.**

*Note: Wait for wheel to stop before raising the hood.*

### **8. Rotate wheel to inboard (left plane) position of unbalance.**

### **9. Attach inboard (left plane) corrective weight.**

*Attach specified weight amount at top-dead-center on inside flange of wheel.*

### **10. Rotate wheel to outboard (right plane) position of unbalance.**

### **11. Attach outboard (right plane) corrective weight.**

*Attach specified weight amount at top-dead-center on outside flange of wheel.*

### **12. Lower the hood to respin the tire/wheel and check balance.**

*Your weight readings should now be 0.00.*

*Note: Throughout this manual tire dimensions are referred to as A, W, and D, see figure 4.*

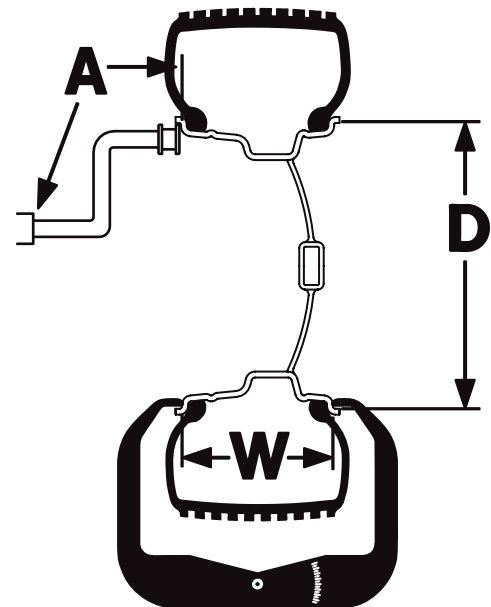

Figure 4 - A, W, and D Tire Dimensions

## Principal Operating Parts

### Do It Now!



Now is a good time to contact product service (800-688-6359) to start warranty, otherwise warranty starts at time of shipment.



Replace any damaged or missing safety decals. They are available from Hennessy Industries, Inc., (800) 688-6359.



Model 550 Shown

## Know Your Unit

Compare this illustration with the unit before placing it into service. Maximum performance and safety will be obtained only when all persons using the unit are fully trained in its parts and operation. Each user should learn the function and location, of all controls.

### 1 Control Panel

### 2 Plug (back of machine)

### 3 ON/OFF Switch

### 4 Wheel Guard

### 5 Offset Arm

### 6 40 mm Shaft

### 7 Weight Tray

**Note:** Throughout this manual, wheel weights are referred to as Clip-on or Tape-A-Weight®. Figure 5 shows an example of each weight.



**Clip-on Weight**

**Tape-A-Weight®**

Figure 5 - Corrective Weight Examples. For Best Results, use BADA® Brand Wheel Weights.

## Power Switch

The ON/OFF switch location (figure 6) is on the left side of the balancer; below the weight tray.



Figure 6 - On/Off Switch

## Operating the Balancer

### Wheel Mounting

Select the most appropriate mounting method for the wheel you are balancing. Using the proper method ensures secure mounting and safe balancer operation, and prevents damage to the wheel.

On most wheels, the inner side of the wheel hub usually has the most uniform surface for wheel balancing. Always center the wheel by the most uniform shaped side of the hub to achieve the most accurate balance.

Regardless of mounting type, always make sure that the wheel is forced firmly against the shaft faceplate and that the hub nut engages the threaded shaft for at least four complete turns. To assist in centering the wheel properly, rotate the wheel and the shaft while tightening the hub nut.



**Failure to tighten the hub nut properly may result in the wheel dismounting, causing personal injury and property damage.**

### Standard Back Cone Mounting

Most original equipment and steel wheels can be mounted properly using this method. The wheel is centered on a cone from the inner side of the hub.

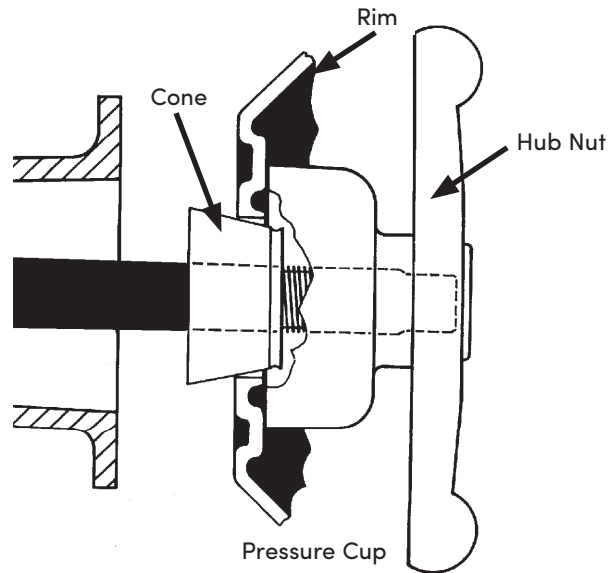

Figure 7 - Back Cone Mounting

- 1.** Select the cone that best fits the center hole in the wheel. Slide the cone onto the shaft with the large end towards the faceplate.
- 2.** Lift wheel onto the shaft and center it on the cone.
- 3.** Attach the pressure cup to the hub nut and install the assembly onto the shaft. Tighten securely.



*Use a nylon spacer (no mar ring) to protect custom wheel finishes.*

- 4.** Thread the hub nut onto the shaft, and tighten it against the wheel. The wheel must be forced firmly against the faceplate. The hub nut must engage the threads for at least three full turns.



*If the hub nut will not tighten completely, use the front cone mounting method.*

## Standard Front Cone Mounting

A wheel should be centered by the outer side of the hub only when the inner surface will not provide an accurate surface to center on.

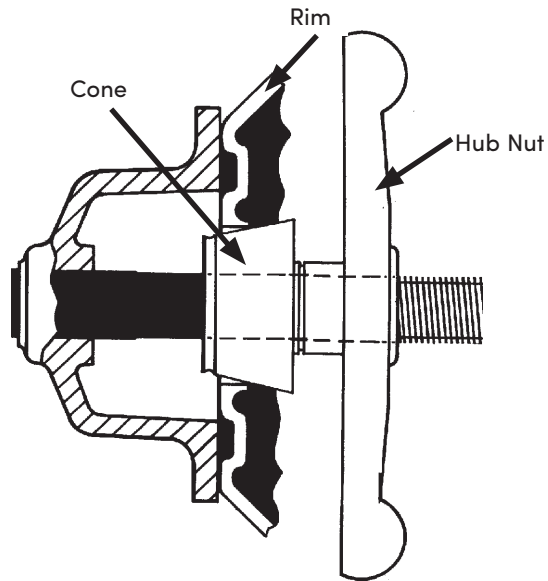

Figure 8 - Front Cone Mounting

- 1.** Select the cone that best fits the center hole in the wheel.
- 2.** Lift the wheel onto the shaft and slide it back against the shaft faceplate.
- 3.** Slide the cone onto the shaft and into the center of the wheel. You will need to lift the tire to seat the cone in the center hole.
- 4.** Install the hub nut (without pressure cup) onto the shaft. Tighten it securely against the cone. The hub nut must engage the threads for at least three full turns.



*Note: If the hub nut will not tighten completely because of a lack of threads, use an additional cone as a spacer between the mounting cone and the hub nut. The wheel must be forced firmly against the faceplate*



Press the buttons with your fingers only.

Never use the counterweight hammer or other pointed objects! Note: Only press buttons with your fingers. Never use the weight hammer or other pointed objects to press buttons

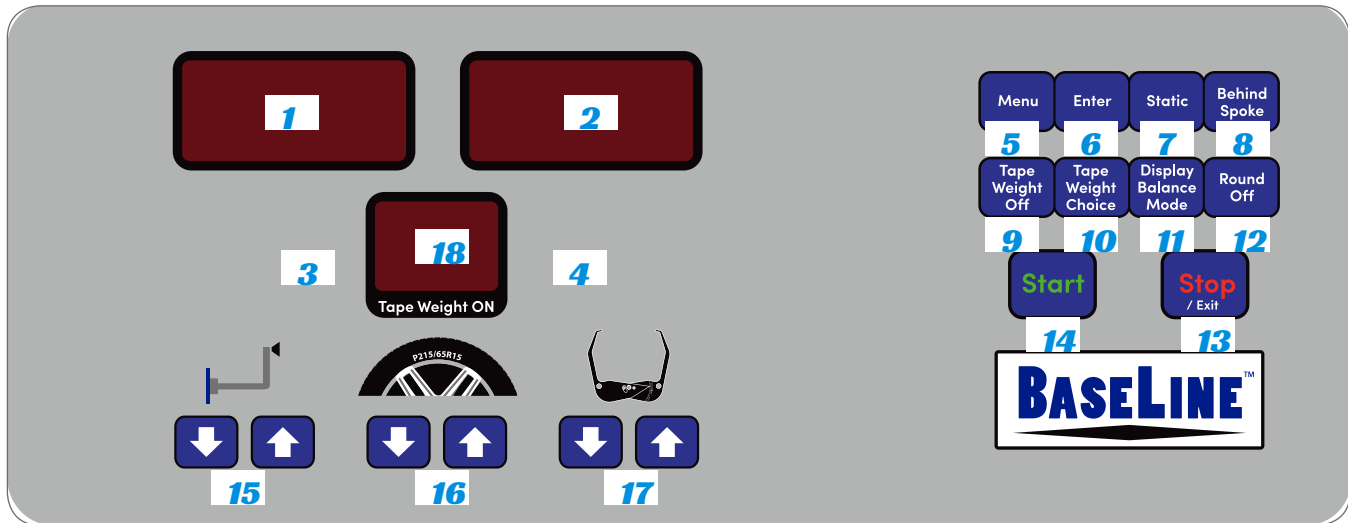

Model 350

- 1-2** Digital readouts, AMOUNT OF UNBALANCE, inside/outside
- 3-4** Digital readouts, POSITION OF UNBALANCE, inside/outside
- 5** Push button, FUNCTION MENU
- 6** MENU selection confirmation push-button and dimensions setting
- 7** STATIC selection button
- 8** Push button, SPLIT (unbalance resolution)
- 9** DYNAMIC selection button
- 10** Display correction mode selected button
- 11** Correction mode display button
- 12** Push button, unbalance reading below the threshold
- 13** Balancing cycle stop button
- 14** Balancing cycle start button
- 15** Manual DISTANCE setting buttons
- 16** Manual DIAMETER setting buttons
- 17** Manual WIDTH setting buttons
- 18** Dot matrix display



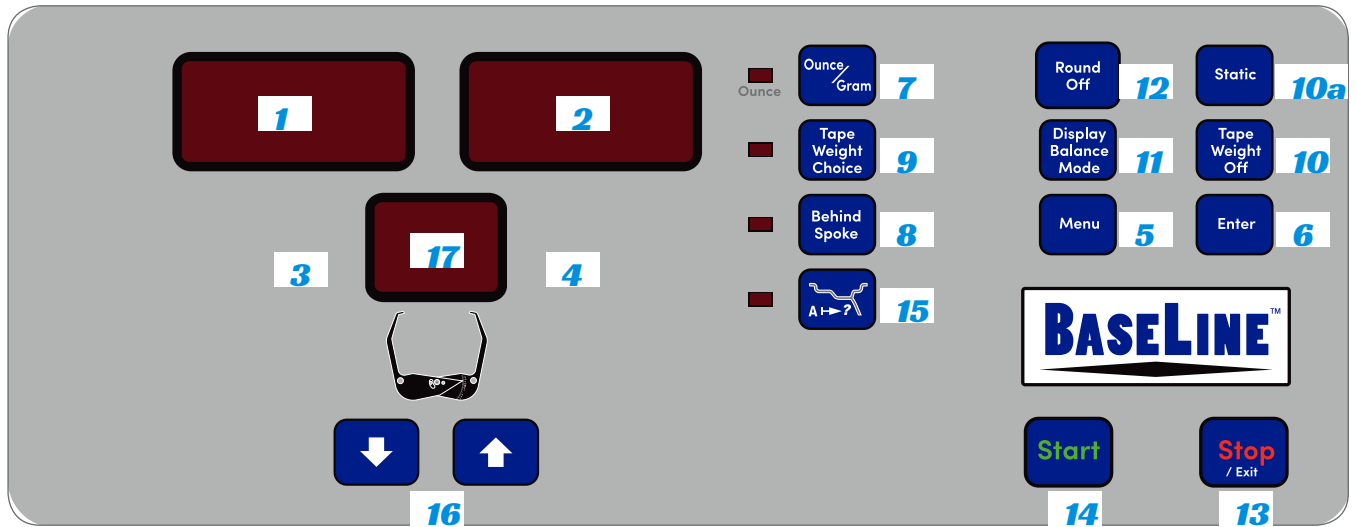

### Model 550

- 1-2** Digital readouts, AMOUNT OF UNBALANCE, inside/outside
- 3-4** Digital readouts, POSITION OF UNBALANCE, inside/outside
- 5** Push button, FUNCTIONS MENU
- 6** MENU selection confirmation push-button and dimensions setting
- 7** Push button unbalance unit of measure
- 8** Push button, SPLIT (unbalance resolution)
- 9** ALU correction mode selection button
- 10** DYNAMIC correction mode selection button
- 10a** STATIC correction mode selected button
- 11** Display correction mode selected button
- 12** Push button, unbalance reading below the threshold
- 13** Balancing cycle stop button
- 14** Balancing cycle start button
- 15** Position repeater push button
- 16** Manual WIDTH/DISTANCE/DIAMETER setting buttons
- 17** Special function indicators

# Operation Functions Menu

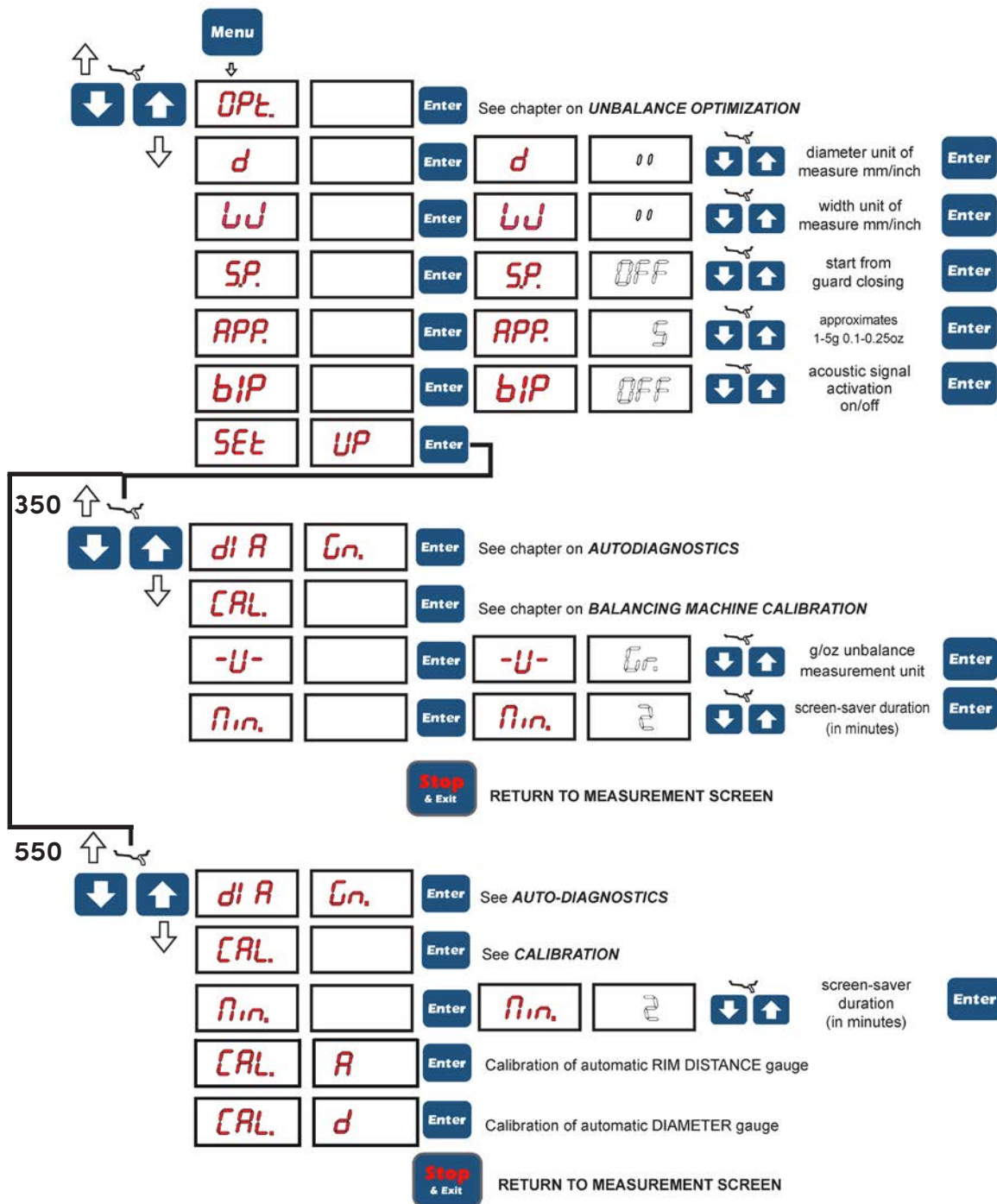

## Correction Modes

From the measurement screen, press

**Tape Weight Choice**

button to select the type required. If a

spin has already been performed, the processor automatically recalculates, for each change of mode, the amounts of unbalance according to the new calculation.

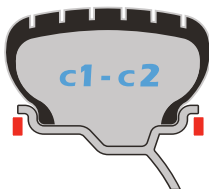

Balancing of steel or light alloy rims with application of clip-on weights on the rim edges.

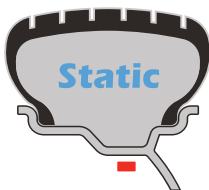

The static mode is necessary for motorcycle wheels or when it is not possible to place the counterweights on both sides of the rim.

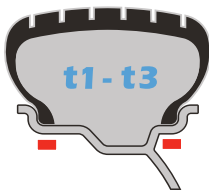

Balancing of light alloy rims with application of adhesive weights on the rim shoulders.

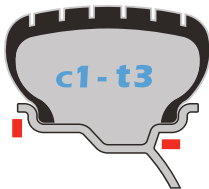

Combined application: adhesive weight outside and clip-on weight inside. (550) Combined balancing: adhesive weight on the inside and clip-on weight on the outside.

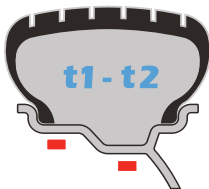

Balancing of light alloy rims with hidden application of the outer adhesive weights. The dimensions can be set. (see MANUAL SETTING t1-t2)

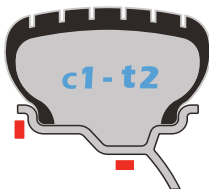

Combined application: clip-on weight inside and hidden adhesive weight on outside (Mercedes). The dimensions can be set. (see MANUAL SETTING c1-t2)

To check the type of correction selected, hold the

button **Display Balance Mode**, while on the matrix display the rim

symbol appears with the correction weights flashing in the right application position.

This information remains displayed only as long as the button is held down. To cancel any type of correction and return directly to dynamic unbalance, press

the button **Tape Weight Off** that returns to c1-c2 mode.

# Manual Presetting of Wheel Dimensions - Model 350

## Standard wheels:

c1-c2/STATIC/t1-t3/c1-t3

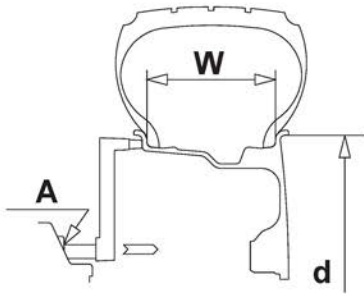

- a. Set the DISTANCE "A" between the inner side of the wheel and the machine. Use the relative gauge on the machine to measure this.

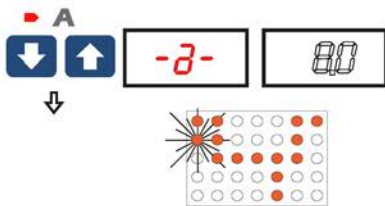
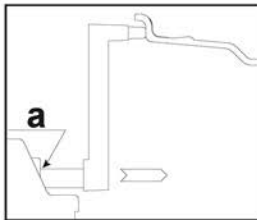

- b. Set the rated WIDTH, normally indicated on the rim, or measure the width "W" using the supplied calliper gauge.

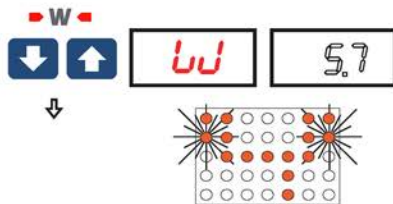
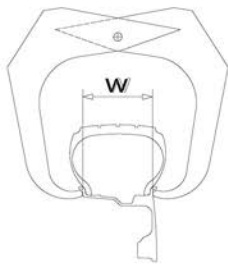

- c. Set the rated DIAMETER "d" indicated on the tire.

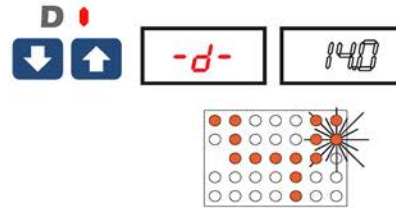

## t1-t2 Wheel

Select the correction position according to the method used to apply the weights to the wheels. Use the gauge to measure the distances according to the following scheme.

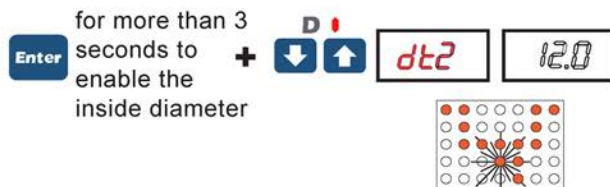
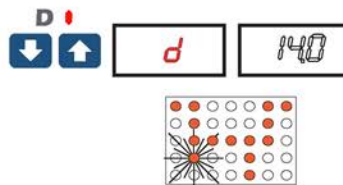
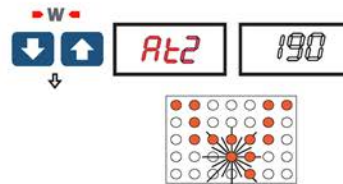
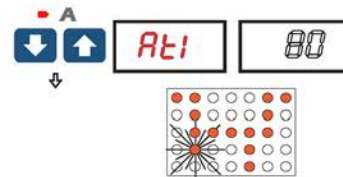
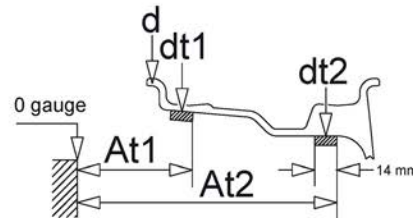

for more than 3 seconds to enable the inside diameter

$$dt1 = d \text{ set} - 1''$$

When dt1 is not set, dt2 = d1 - 2'' is automatic

**c-1-t2 wheel**

Measure the dimension as shown in the following diagram.

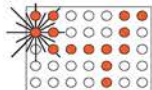
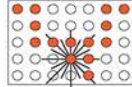
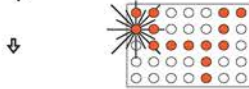
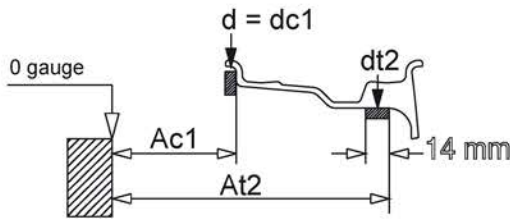

for more than 3 seconds to enable the inside diameter

**Enter** + **D** ↓ ↑ **dt2** 120

When dE is not set, dE = d - 2" is automatic.

To set dE press at the same time **Enter** + **D** ↓ ↑

**Measurement Result - Model 350**

**Inside correction**

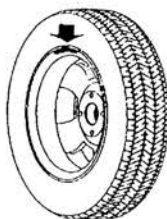
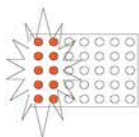

**Outside correction**

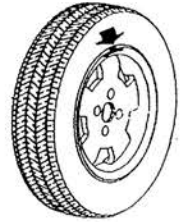
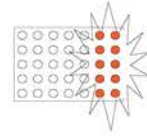
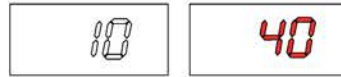

Move the wheel manually until all the LED's corresponding to the side light up. The display shows the measured unbalance. For unbalance within tolerance 0 (zero); using **Round Off** values within tolerance can be viewed.

**INFORMATION**

If at the end of any balancing run, the flashing symbol



appears, manually turn the wheel until unbalances are displayed.

**Spilt Function (unbalance resolution) - Model 350**

The SPLIT function is used to position the adhesive weights behind the wheel spokes (angle > 18°) so that they are no longer visible (for alloy rims). Use this function in the ALU or STATIC mode where the adhesive weight is applied inside the rim.

At the end of the measurement spin:

- a. Turn the wheel to the outer side unbalance correction position.

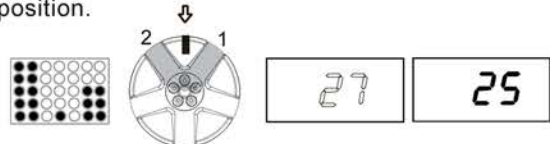

- b. Move one of the spokes to 12 o'clock (e.g.: 1) and

press **Behind Spoke**

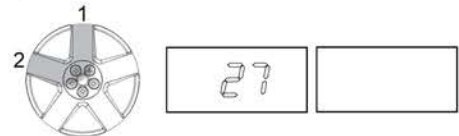

- c. Following the direction of rotation indicated by the position LED's, move spoke 2 to 12 o'clock and press

**Behind Spoke**

. The value to use for correction in position 2 is displayed.

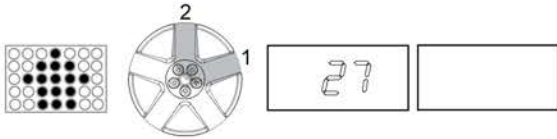

d. Move spoke 1 to the correction position as indicated by the position LED's

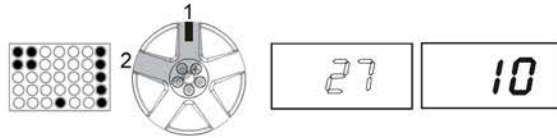

Repeat the operation for the other spoke

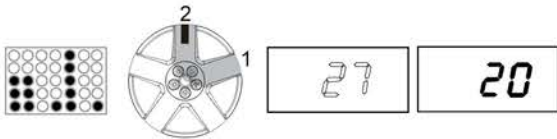

To return to the normal unbalance indication press any button.

**INFORMATION**

The distance between the spokes must be at least 18° and at most 120° (if not, the errors 24,25 or 26 appear). Spokes with irregular or inconstant angles can be compensated.

**Unbalance Optimization - Model 350**

This operation is performed to reduce the static unbalance of the wheel. It is suitable for static unbalance values in excess of 30 grams.



a. If no unbalance was measured before, START appears on the display. Press this button to proceed.

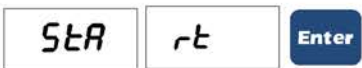

b. Make a reference mark on the flange and the rim (using a piece of chalk, for example). With the aid of a tyre remover, turn the tyre on the rim by 180°. Refit the wheel in such a way that the reference marks on the rim and the flange coincide.

Press START to begin reading.

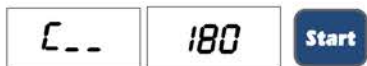

c. RH display: percentage reduction value  
LH display: actual static unbalance value which can be reduced by rotation



d. Mark the two positions of the rim and tyre, and turn the tyre on the rim until the positions coincide to achieve the optimisation shown on the display

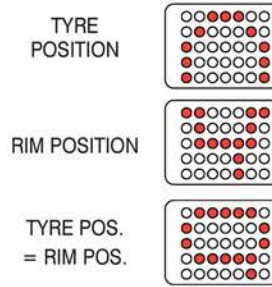

To cancel optimisation at any time, press .

## Presetting of Wheel Dimensions - Model 550

The balancing data is set by means of an "intelligent" automatic gauge; confirmation of the measurement and the position appear on the display. The round part of the gauge must rest on the rim where the weight will be positioned.

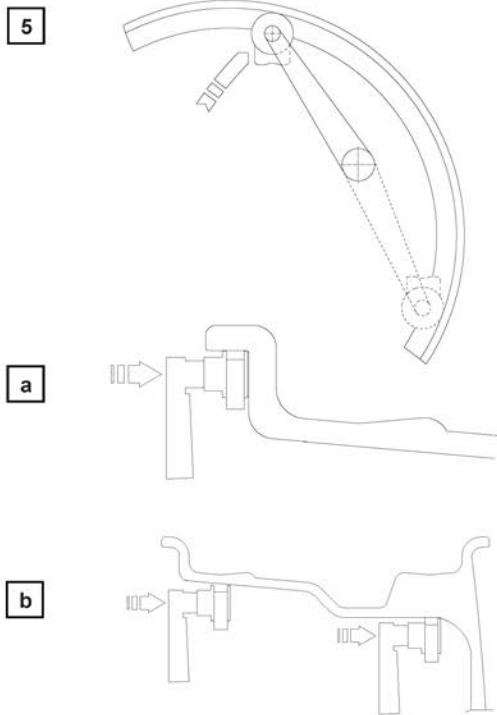

While the gauge is moving the following appears:



when the measurement has been stored:



**a) standard weights:** when only one measurement is made, the machine interprets the presence of a rim with clip-on weight correction



The width value (W) must be set with the buttons



The correct measurement is that which can be measured with the compass gauge provided.



**b) adhesive weights:** make two successive measurements on two correction planes inside the rim.



The balancing machine automatically interprets that the correction will be made with adhesive weights and the following appears:

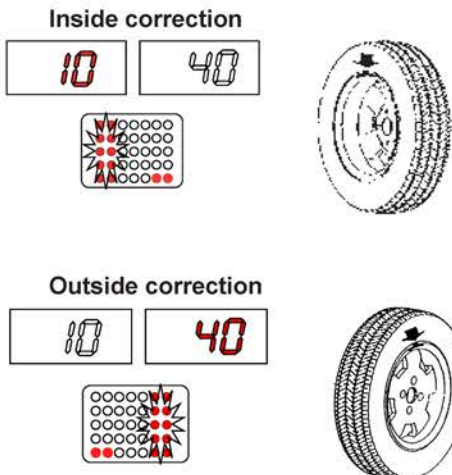

For a different combination of the type or position of the weights on the rim, use the **Tape Weight off** / **Static** button.

## Measurement Result - Model 550



After performing a balancing spin, the amounts of unbalance are shown on the digital readouts. Digital readouts with LED lit up indicate the correct angular wheel position to mount the counterweights (12 o'clock position). If the unbalance is less than the threshold selected,  is displayed instead of the unbalance; with  it is possible to read the values below the threshold chosen.

### INDICATION

If at the end of any balancing run, the flashing symbol

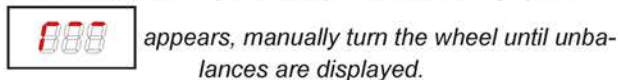

## Unbalance Unit of Measure - Model 550

The unbalance can be displayed in grams or ounces. To select the unit of measure, press the  button. The selection will remain stored even when turning off the wheel balancer.

## Static Unbalance - Model 550

It is selected by pressing  and is shown on the central display. The position is indicated on the displays 3 and 4.

## Exact Positioning Of The Adhesive Weight By Means Of The Gauge With Clips - Model 550

### CLIPS

- Press  if using the correction method t1-t2 and c1-t2 with adhesive weights on the inside of the rim

5c

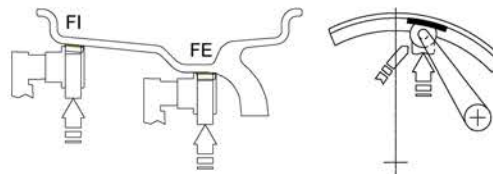

- Fit the correction weight in the specific gauge seat with the adhesive part facing upwards
- Bring the wheel into correct angular position for the plane to be corrected
- Pull out the gauge up to the distance set (see **DATA SETTING**)
- If the buzzer is enabled (see **MENU**), the attainment of the weight application distance is accompanied by a beep.
- When the weight application distance has been reached a beep is sounded (can be deactivated).
- Using the special weight pusher, rotate the gauge until the correction weight adheres to the rim
- the fact that the weight application position is no longer vertical (see figure) is automatically compensated

- INSIDE CORRECTION POSITION

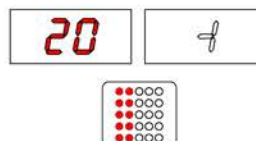

- OUTSIDE CORRECTION POSITION

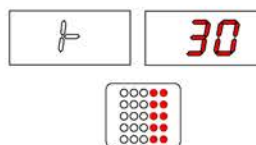

### INDICATION

The approach of the weights to the correction positions is indicated by the LEDs number 17. The position repeater works only in pos. A as shown in figure 5c.

To cancel the function, press the  button again.



## Spilt Function (unbalance resolution) - Model 550

The SPLIT function is used to position the adhesive weights behind the wheel spokes (angle > 18°) so that they are no longer visible (for alloy rims). Use this function in the ALU or STATIC mode where the adhesive weight is applied inside the rim.

Enter the wheel dimensions in the ALU M mode and press START.

- Turn the wheel to the outer side unbalance correction position.

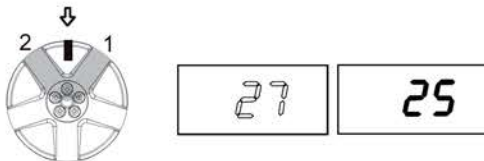

- Move one of the spokes to 12 o'clock (e.g.: 1) and press **Behind Spoke**

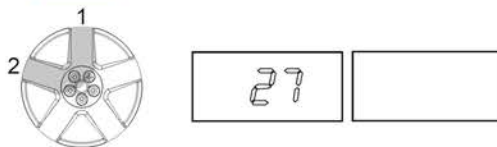

- Following the direction of rotation indicated by the position LED's, move spoke 2 to 12 o'clock and press **Behind Spoke**. The value to use for correction in position 2 is displayed.

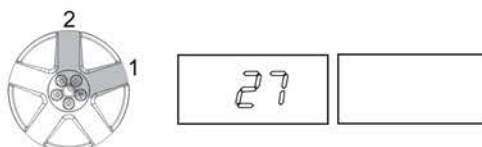

- Move spoke 1 to the correction position as indicated by the position LED's

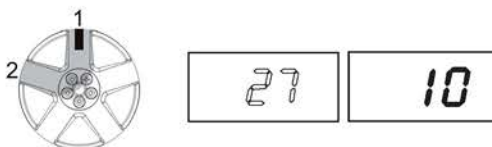

To return to the normal unbalance indication press any button.

### INFORMATION

*The distance between the spokes must be at least 18° and at most 120° (if not, the errors 24, 25 or 26 appear).*

*Spokes with irregular or inconstant angles can be compensated.*

## Maintenance Instructions

Read and follow all the maintenance instructions provided in this manual to keep the machine in good operating condition. Refer to the other materials received with the unit and to the service bulletins from the manufacturer for additional instructions on proper maintenance and service. Regular inspections and proper maintenance are essential to preventing accidents and injuries.



Always **DISCONNECT ELECTRICAL POWER** and block out all moving parts before making any inspection, adjustment, or repair to the machine. This prevents electrical shock or accidental movement of the systems operated by the electrical power.



Use common sense, this is an electrical device. Exposing the balancer to water, either by hose or bucket, or by exposure to rain or snow, may cause risk of shock or electrocution to operator or bystanders. Place, store, and operate the balancer only in a dry, sheltered location.



Keep the machine and the immediate work area clean. Do not use compressed air to remove dirt and debris from the machine. Foreign material may be propelled into the air and into operator or bystander causing personal injury.



Wear protective clothing, equipment and eye protection when making any adjustments or repairs to the machine.



Do not hose down with water or bucket wash the balancer. Extensive damage to the balancer will result. Sensitive electronic components, wiring harnesses, and other devices housed in the balancer are not intended to be exposed to water.



Replace any damaged or missing safety decals. They are available from Hennessy Industries, Inc., (800) 688-6359.

The balancer requires only minor maintenance to keep the unit operating properly.

**1.** Keep the display clean and clear. Use a damp cloth. Do not use cleaners or solvents which leave oily or filmy residues behind.

**2.** Keep the adapters, cones, faceplate, threaded shaft, pressure cup, and hub nut clean. Grease and dirt buildup will cause inaccurate balancing and premature wear. Clean these items at least once a day with a vaporizing solvent.

**3.** Clean weight tray and any accessory posts, pegs, or storage shelves with a vaporizing solvent. Weights stored in a dirty tray may pick up grease and dirt which may keep them from securely attaching to the wheel.

**4.** Keep the area around the balancer clear. Remove any tools or other items that are leaning against the balancer. Keep the area under the balancer clear. Remove any items that may cause the balancer to not sit level. Be particularly cautious of new or used wheel weights on the floor, as they may cause personal injury due to falls.

**5.** Use only Hennessy Industries, Inc. accessories. Accessories from other manufacturers may not fit or function properly, and may damage the balancer.

# Diagnostic Procedures

## Self Diagnostics

The machine can perform self-diagnostics to check the LED's on the control panel and make sure the encoder reads correctly.

To perform this operation, view the SETUP menu.

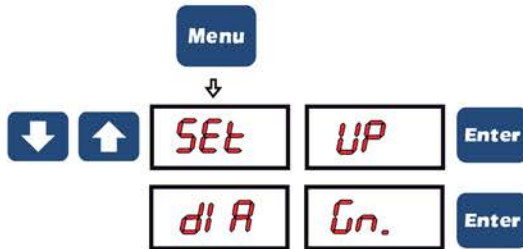

In the self-diagnostics sequence, all the LED's on the panel light up for a few seconds in order to check operation. When the LED's go out, the machine automatically moves on to the encoder reading phase. When the wheel is turned manually (forwards and backwards), the display shows its exact position. The value lies between 0 (zero) and 255.

## Machine Calibration

To calibrate the machine, proceed as follows:

- Fit an average size wheel with a metal rim on the shaft. Example: 6" x 15" ( $\pm 1$ ").
- Set the wheel measurements as described in paragraph **USE OF THE WHEEL BALANCER**.



### CAUTION

SETTING INCORRECT DIMENSIONS WOULD MEAN THAT THE MACHINE IS NOT CORRECTLY CALIBRATED, THEREFORE, ALL SUBSEQUENT MEASUREMENTS WILL BE INCORRECT UNTIL CALIBRATION IS PERFORMED ONCE AGAIN WITH THE CORRECT DIMENSIONS.

Display the SETUP menu:

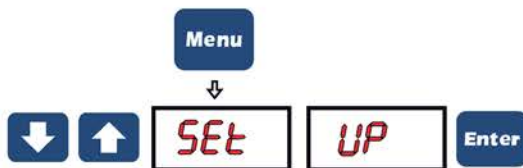

1. Press to view the CALIBRATION function.

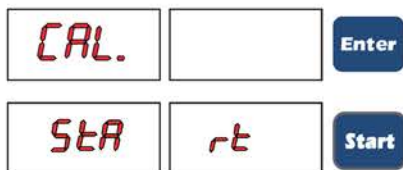

2. Add a standard weight of 4.00 oz (100 g.) to the outer side, in any position.



3. Shift the standard weight from the outside to the inside keeping the same position.



4. Turn the wheel until the standard weight is at the top (12 o'clock).



5. End of calibration.



To cancel calibration at any time, press



## After Balance Vibration Problems

If vibration is still present after balancing the wheels and driving the vehicle on smooth pavement, remove the wheels and recheck the balance. If a wheel is out of balance the cause maybe:

- *Wheel was not mounted/centered correctly on the balancer.*
- *A weight has come off the wheel (possibly the wrong clip style). Remove the other weights from the wheel and rebalance.*
- *Foreign material inside the tire. Remove the tire from the wheel, remove the foreign material, and remount. Remove wheel weights and rebalance the wheel.*
- *Stones or other foreign objects caught in the tire tread or rim. Remove the objects. Check and rebalance if needed.*

If the balancer still indicates the wheels are balanced to within 0.10 ounces on both inner and outer displays, the problem is not in the balance of the wheels. Check the following possible sources of vibration:

- *Tire pressure. Bring all tires up to the recommended PSI.*
- *Radial or lateral runout in the tire or wheel. Replace the damaged part.*
- *Unbalance in wheel covers or trim rings. Remove the wheel covers or trim rings and test drive. If the vibration is gone, remove the shaft and use an appropriate adapter to mount the wheel to the balancer. Balance the wheel with the wheel cover or trim ring attached to the wheel.*
- *Incorrectly mounted wheel. Remount correctly.*
- *Damaged wheel bolt holes. Replace wheel.*
- *Worn universal joints. Replace as required.*
- *Drive shaft unbalance or damaged. Balance, repair, or replace.*
- *Unbalance in brake rotor(s) or drum(s).*
- *Suspension out of alignment. Align the vehicle and replace any damaged or worn parts. Pressure Limiter Maintenance*

# NOTES

