

BASELINE™

Rim Clamp® Tire Changers

For servicing single piece automotive and most light truck tire/wheel assemblies.



Model 300 Shown



Model 500 Shown

Parts Identification

READ these instructions before placing unit in service. **KEEP** these and other materials delivered with the unit in a binder near the machine for ease of reference by supervisors and operators.

Parts Identification

The following pages include parts breakdowns with exploded view illustrations to help with ordering replacement or spare kits. Assemblies are noted where it is recommended that individual parts not be ordered separately. Note that the parts view illustrations are for multiple models and not all parts shown are on all models. Every effort is made to supply accurate exploded views, however, due to interim changes in manufacturing operations, some units may not be exactly as illustrated.

Duckhead® and Rim Clamp® are registered trademarks owned by Hennessy Industries, Inc.

Baseline™ and Robo-Assist™ are trademarks owned by Hennessy Industries, Inc.

Regal® is a registered trademark owned by Chevron Intellectual Property LLC.

Table of Contents

Parts Identification	2
Swing Arm Assembly	4
Pressure & Inflation Bracket Assemblies	5
Chassis Assembly	6
BL Arm Assembly	6
Foot Pedal Assembly.....	7
Table Top & Shaft Housing Assemblies.....	8
Robo-Assist™ Assembly	9
* Hose Reels	9
Cylinder Assemblies	10
Pneumatic Diagram	11
Cable Assemblies and Circuit Breakers	12
Electrical Diagram	13
General Maintenance	14
Torque Specification Chart.....	14
Lubrication Points	14
Oil Injector Maintenance	15
Transmission Lubrication.....	15
Air Gauge Check.....	15
Danger, Warning, Caution, and Instructional Decals	15
Decal Layout	16

Swing Arm Assembly

Item No	Part No.	Description
1	85607535	M8 x 1.25 x 20mm BHSCS Screw
2	85606864	Vertical Slide Cap
3	8182028	Vertical Slide Spring
4	85606856	Vertical Slide Lock Plate M12 THD
	85610488	Vertical Slide Lock Plate 1/2-13 THD
5	85606860	M12 x 1.75 Jam Hex Nut
	8181113	1/2-13 Jam Hex Nut
6	85606861	Lock Plate Lift Pin M12 THD
	85610487	Lock Plate Lift Pin 1/2-13 THD
7	85610462	Swing Arm Weldment M12 THD
	85610489	Swing Arm Weldment
8	85606859	Lock Handle Shim
9	85606851	Lock Cam Weldment w/Handle
10	7000230	Handle Grip 1/2 x 3"
11	85606855	Vertical Slide Shaft
12	85606857	Rubber Stop Bumper
14	8130026	3/8-16 x 1/2 SHSSCP Screw
15	8182027	Washer 7GA x 0.406ID x 1.28OD
16	85607525	M10 x 20mm HWHCS Screw
17	8140667	1/4-20 x 1/4 SHSSCP Screw
18	8182786	Dowel Pin 5mm x 25mm
19	8182787	Roller 9/16 x 0.625 x 0.203
20	81827881	Duckhead® Mount/Demount Tool Pkg.
21	85606862	Retaining Ring-External #5100-98
22	85610541	Swing Arm Kit (Blue)

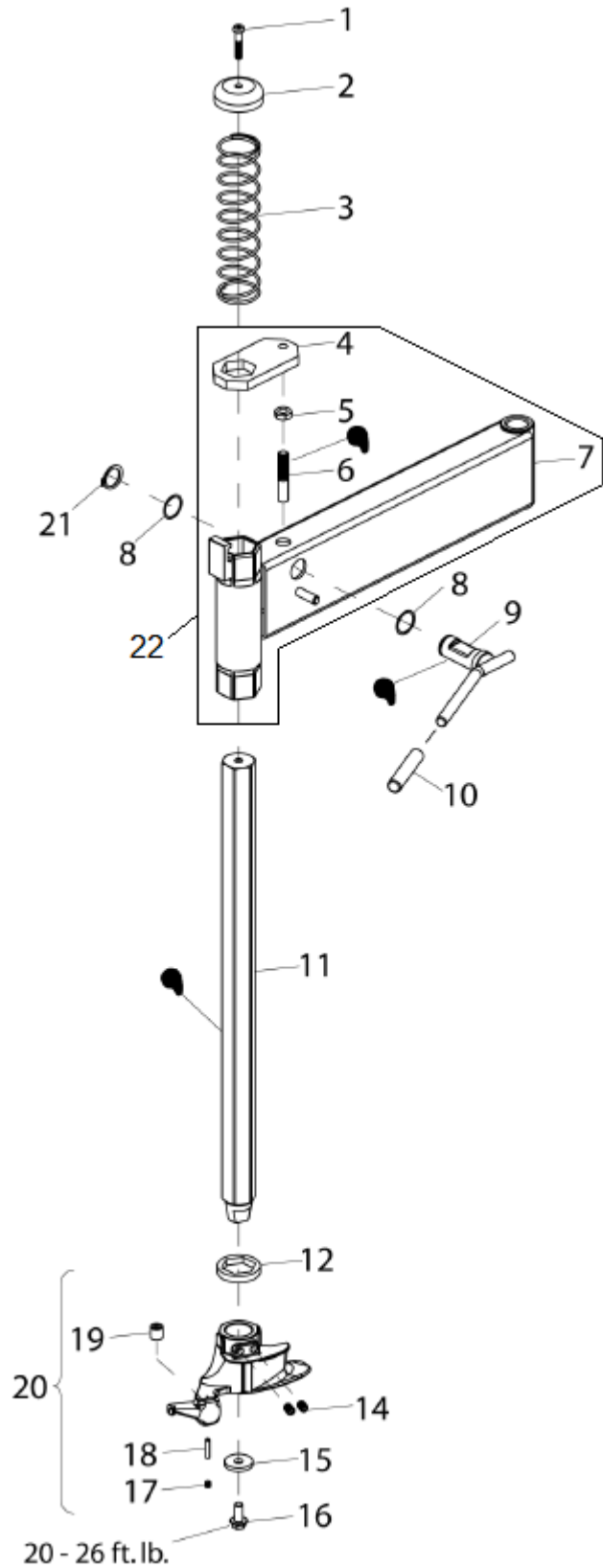

APPLY GREASE TO THESE LOCATIONS

Pressure & Inflation Bracket Assemblies

Item No	Part No.	Description
1	85610449	Inflation Bracket Pedal
2	8102459	3/8-16 x 0.860 HWHSTCS Screw
3	8107407	Hitch Pin
4	85610450	Inflation Valve Bracket
7	8111083	Preset Pressure Regulator, 60PSI
10	8180103	Clevis Pin 0.375 x 3.250
12	85607184	3/4-14 NPT x 12mm Y Fitting \]=o,
13	85606722	Dual Stage Inflation Valve
20	85606917	M12 Plain Washer
21	85606984	M12 x 1.75 x 75mm HHCS Bolt
22	85610451	Air Receiver Tower
23	85606985	M16 x 1.5 Jam Nut
24	85606988	M16 Flat Washer
25	85606989	Adjusting Knob Assembly
26	87661701	Air Gauge
27	85606362	Hose Clamp - Spring 13mm
28	85606986	M16 x 1.5 Pivot Bolt, Swing Arm
29	85606987	M24 Flat Washer
30	8182599	200 PSI 1/4NPT Relief Valve
31	8110497	1/8 NPTM x 1/4 Hose Elbow Fitting 90
32	8109471	1/8 NPTM Fitting - Nipple
33	85607348	1/4 NPTM Fitting - Nipple
34	85000627	Regulator (200 PSI Max.)
35	8184256	90° Elbow Fitting
36	8104573	3/4 Straight Fitting
37	85607368	M5 x 0.8 Nylock Hex Jam Nut
38	8101312	3/4 NPTM x 1/4 NTTF Reducer Fitting
39	85610425	1/4 NPTF x 1/4 NPTM Branch Tee
40	8000378	1/4 NPT Brass Straight Fitting

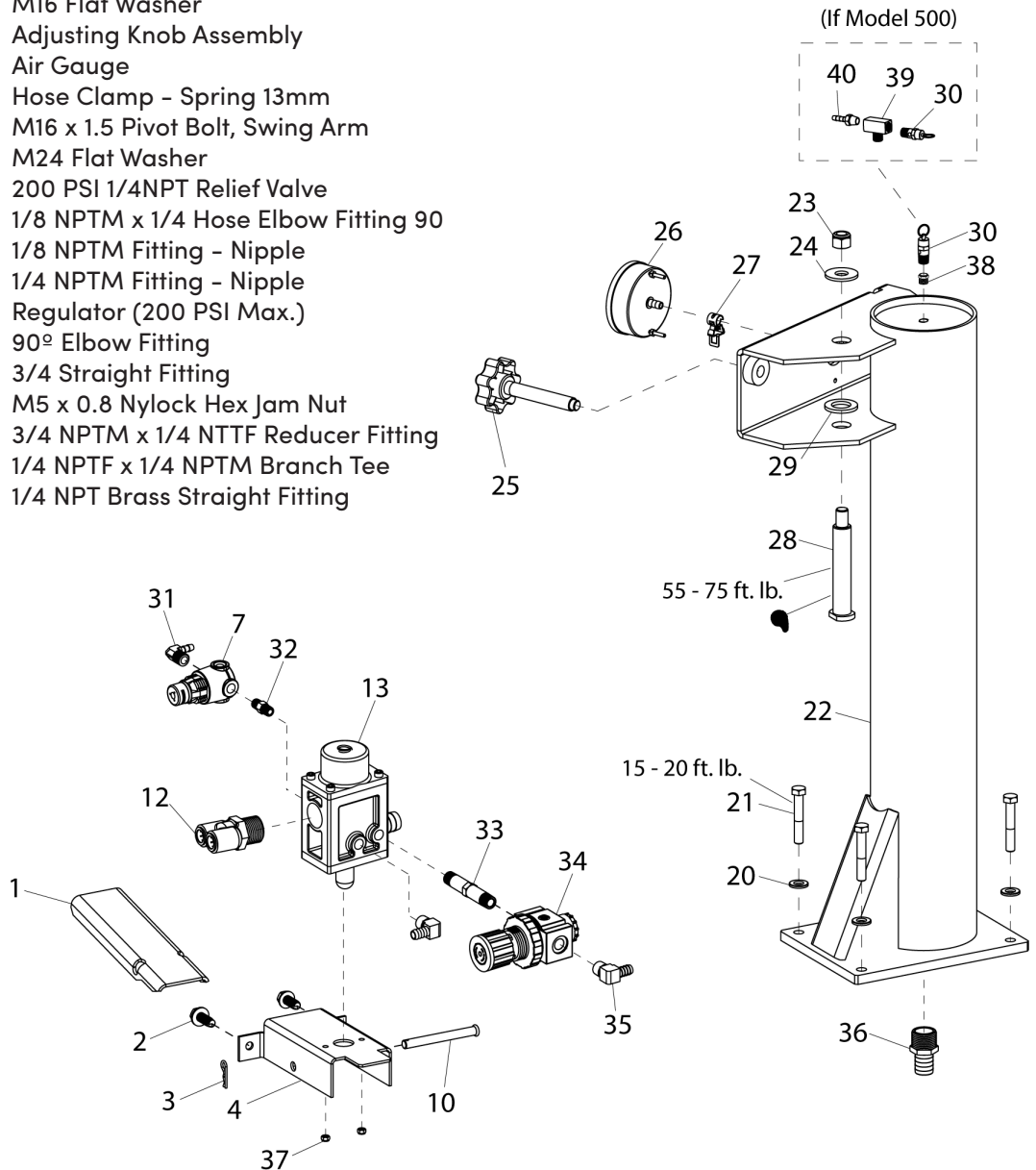

Chassis Assembly

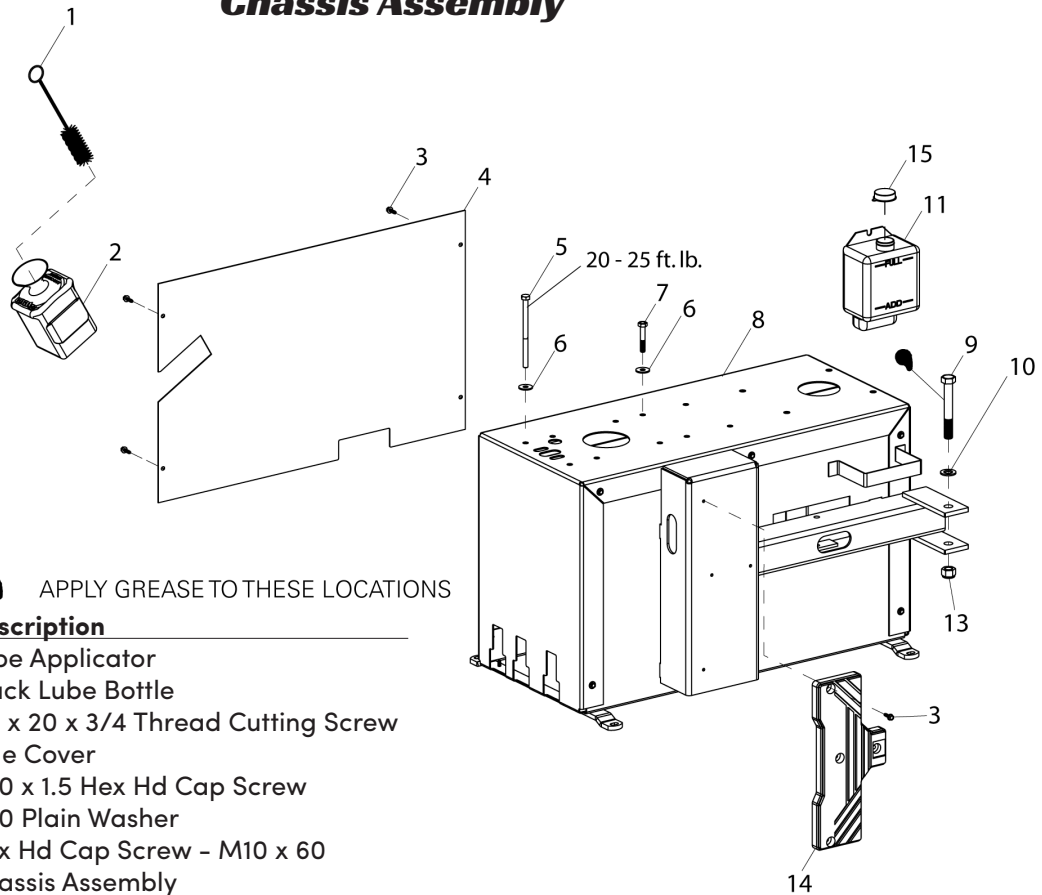

APPLY GREASE TO THESE LOCATIONS

Item No	Part No.	Description
1	8000491	Lube Applicator
2	85610365	Black Lube Bottle
3	8106301	1/4 x 20 x 3/4 Thread Cutting Screw
4	85610452	Side Cover
5	85606979	M10 x 1.5 Hex Hd Cap Screw
6	85606982	M10 Plain Washer
7	85607258	Hex Hd Cap Screw - M10 x 60
8	85607020	Chassis Assembly
9	85608582	3/4" x 3.5" SHSS Screw
10	85607359	M18 Plain Washer
11	85610404	Lubricating Oil Reservoir
13	85610432	5/8"-11 Lock Nut
14	85607027	B.L. Pad
15	85610406	Lube Oil Reservoir Cap, Blk

BL Arm Assembly

Item No	Part No.	Description
1	8182579	M18 x 2.5-130 Bolt
3	8182473	B.L. Shoe Weldment
4	7000230	1/2 x 3 Handle Grip
5	8183326	B.L. Cylinder Assembly
6	85606965	Clevis Pin
7	85607250	Clevis Retainer Clip
8	85606985	M16 x 1.5 Hex Jam Nut
9	8182550	Pivot Pin B.L. Cylinder Rod
10	85610453	B.L. Arm Weldment
11	8182016	3/4-10 Hex Nylock Nut
12	8182558	3/4 Belleville Washer
13	8182557	B.L. Spacer Washer
14	85607419	17 x 30 x 6mm Flat Washer

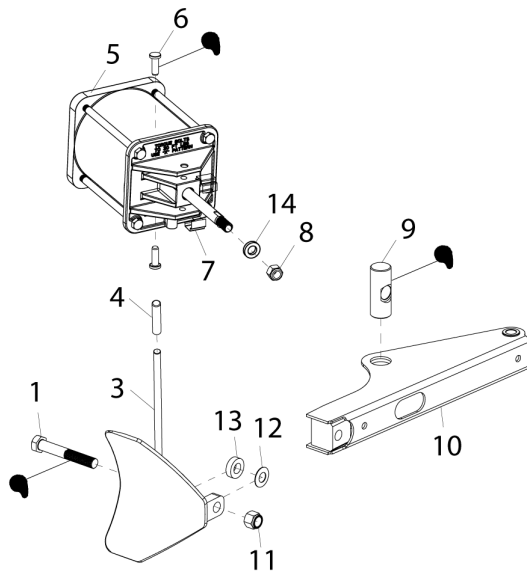

APPLY GREASE TO THESE LOCATIONS

Foot Pedal Assembly

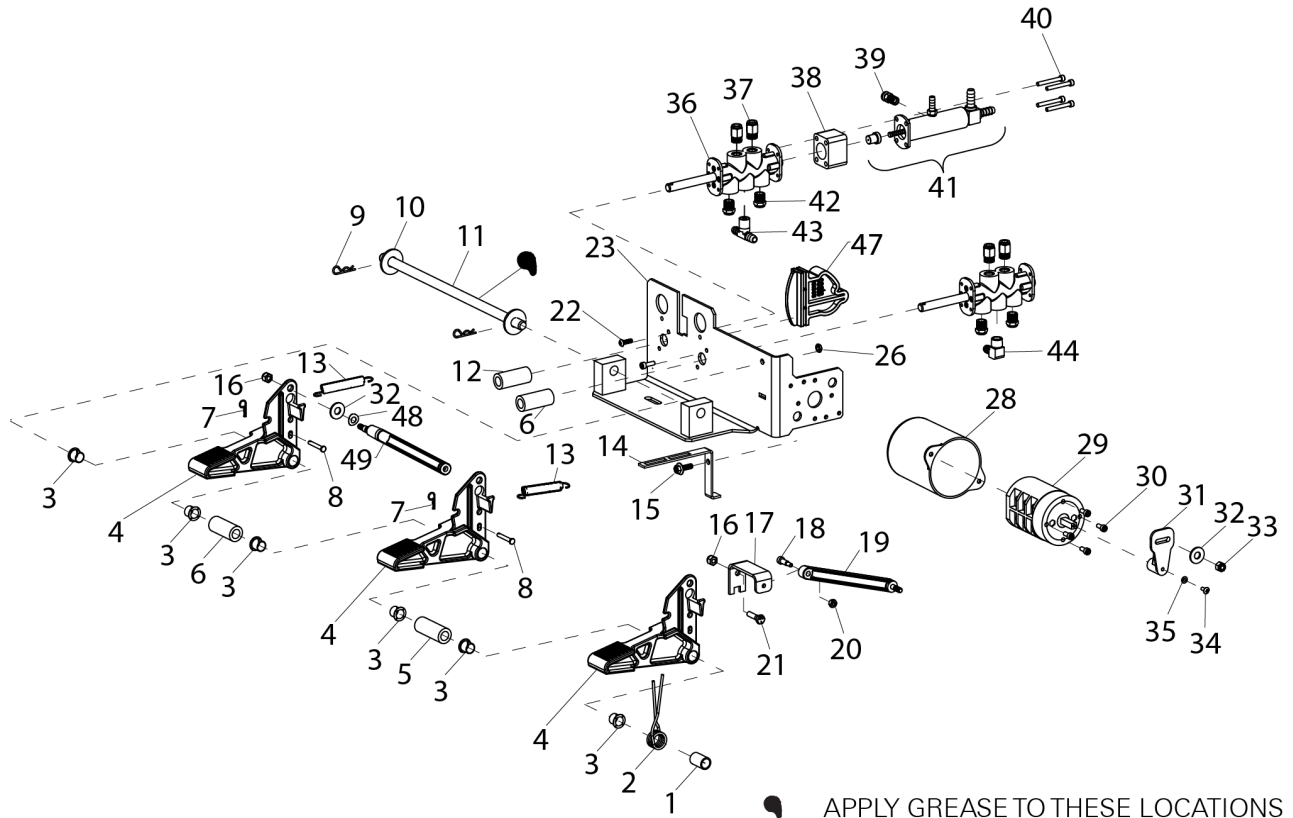

 APPLY GREASE TO THESE LOCATIONS

Item No	Part No.	Description	Item No	Part No.	Description
1	85606974	Switch Spring Sleeve	27	*8150124	4-inch Cable Tie
2	8181707	Torsion Spring	28	85607223	Reverse Switch Cover
3	8181948	1/2" Nylon Flanged Bearing	29	85607520	Switch Reversing, Kit (115V / 230V)
4	8181675	Pedal		8182958	Switch Reversing, Kit (CSA Only)
5	85606972	Pedal Spacer	30	85606977	M5 x 0.8 x 16mm SHC Screw
6	85607347	Grey Pedal Spacer	31	85606973	Switch Actuator Lever
7	8120469	Hitch Clip Pin	32	8107635	Washer
8	8181977	3/16 x 1-1/4 Clevis Pin	33	8181369	1/4-20 Nylock Nut
9	8111609	Hair Cotter Pin	34	8113944	M4-0.7 x 10 HHMS Screw
10	8301121	Washer	35	8114010	4mm Washer
11	8183398	Pedal Retaining Shaft	36	85606879	Valve Assembly, Pedal
12	85607121	Pedal Valve Stopper	37	85607170	8MM x 1/4NPT Straight Fitting
13	8181708	Pedal Extension Spring	38	85607181	Valve Spacer Clamp
14	85610454	Torsion Spring Bracket Guide	39	8103737	Release Valve
15	8143168	1/4-20 x 3/4 Whiz Lock HHCS	40	85607183	#10-24 x 1.5 SHCS Screw
16	8181369	1/4-20 Hex Nut, Zinc Plated Nylock	41	8184675	Oil Injector Assembly
17	85610455	Electrical Switch Extension Bracket	42	8105615	Muffler, Small
18	8182743	10-24 x 3/8 SHSHS Screw Gr.8	43	8184467	1/4 NPT, 3/8" Tee Fitting
19	8181699	Lever Switch Assembly	44	8184256	90° EL Fitting
20	8182682	#10-24 Reversible Lock Nut	45	*85607173	Motor Cable Assembly
21	8181984	1/4-20 1 HHCS Screw	46	*85607172	Power Cord Assembly
22	8181989	10-24 x 3/8 SHCS Screw	47	8181695	Cam Mounting Block
23	85610456	Pedal Valve Bracket Assembly	48	8181981	5/16" Wave Washer
24	85607182	Pedal Valve with Oil Injector	49	8181696	Cam Follower Lever
25	85607198	Pedal Valve Assembly			
26	8143169	1/4-20 Whiz Lock Nut			

* Not Shown

Table Top & Shaft Housing Assemblies

Item No	Part No.	Description
1	85606967	M12 x 1.75 x 29.5 SHCS Screw
2	85606968	Hub
3	8183476	1/4 x 3/4 Roll Pin
4	85607212	Slide Stopper
5	85606865	Weldment Plate
6	8181677	Rim Clamp
8	85607264	1/8 NPT x 10mm PSH 90° Elbow
9	85606904	Carrier Slide Weldment
10	85606916	M12 Spring Lock Washer
11	85606918	Pivot Link Sleeve
12	85606915	M12 1.75 x 30 HHCS Bolt
13	85606907	Carrier/Slide Plate
14	85607010	Cylinder Assembly, TT
15	85606919	Ext. Retaining Ring N5100-46
16	85606920	Flat Washer
17	85000088	1/8NPT x 8MM Elbow Fitting
18	85606913	Pivot Link Weldment
19	85607648	M12 x 1.75 x 40mm HHCS Bolt (24" Clamp)
20	85606910	Pivot Plate Weldment
21	85606971	External Retaining Ring N5100-262
22	940689	M6-1 x 30MM SHCS Screw
23	85607133	Rotating Union
24	85606969	Taper Key
25	85606979	M10 x 1.5 HHCS Bolt
26	85606982	M10 Plain Washer
27	85607871	Gear Box Transmission
28	85607342	M10 Whiz Lock Flanged Hex Nut
29	8180047	Motor Belt
30	8184674	Motor Pulley
31	85607346	M8 Whiz Lock Flanged Hex Nut
32	85610457	Motor Mount Bracket
33	85607361	M10 Cage Nut
34	85607008	Motor, 1HP, 115V, 60Hz, 1Ph 8182621 Motor, 1HP, 220V, 50Hz, 1Ph 8184691 Motor, 1HP, 115V, 60Hz, 1Ph, CSA
35	85607258	M10 x 60 HHCS, Screw
36	85607869	1.75 x 25mm M12, FHSC Screw
37	85608643	Clevis Pin
38	85607647	Top Carrier (24" Clamp) Adjustable
39	85608644	Circle Cotter Pin
40	85607646	Bottom Carrier
41	85609139	Grommet (85607008 Motor only)
42	85609311	M8 x 1.25 x 40mm HHCS Screw
43	8107635	5/16 Plain Washer

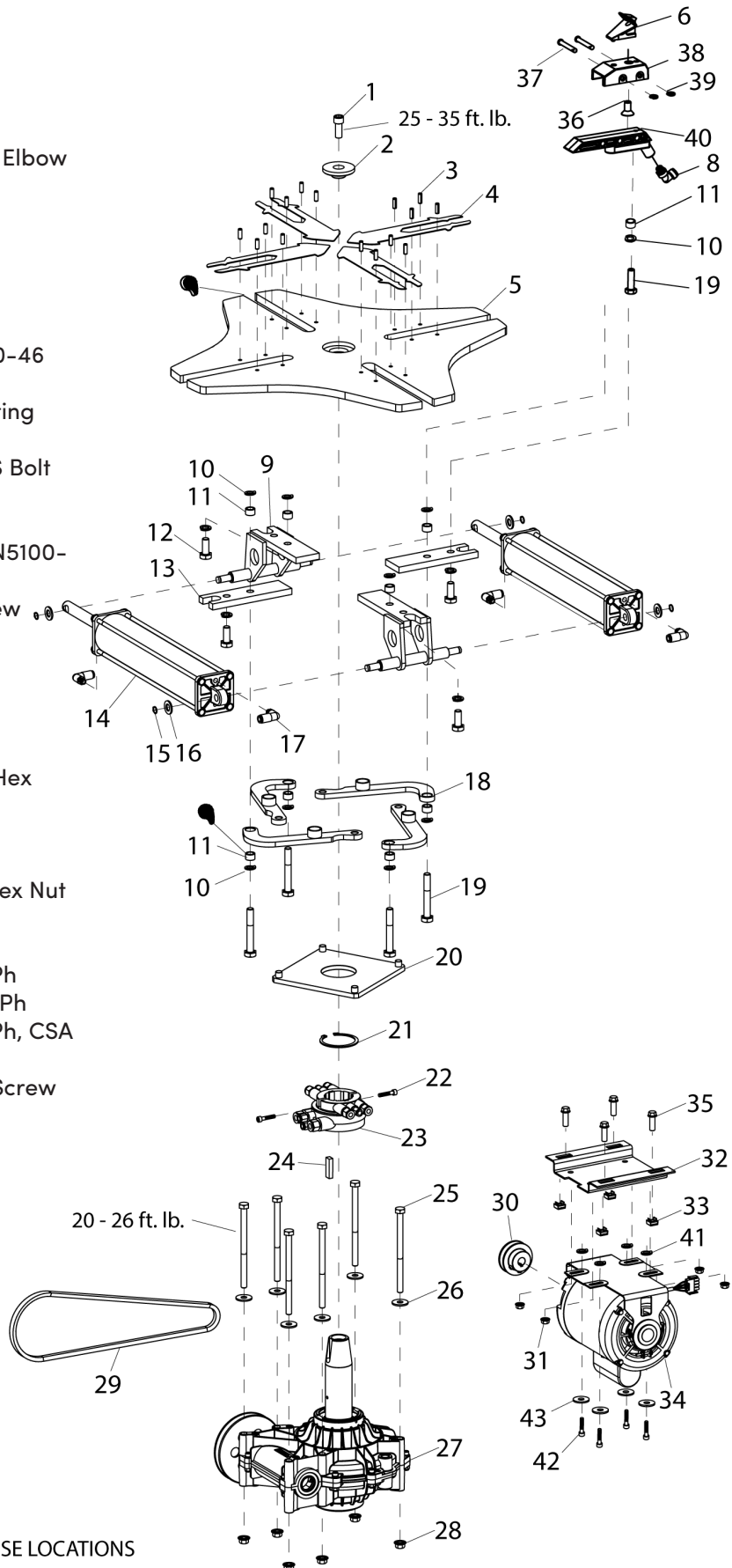

APPLY GREASE TO THESE LOCATIONS

Robo-Assist™ Assembly

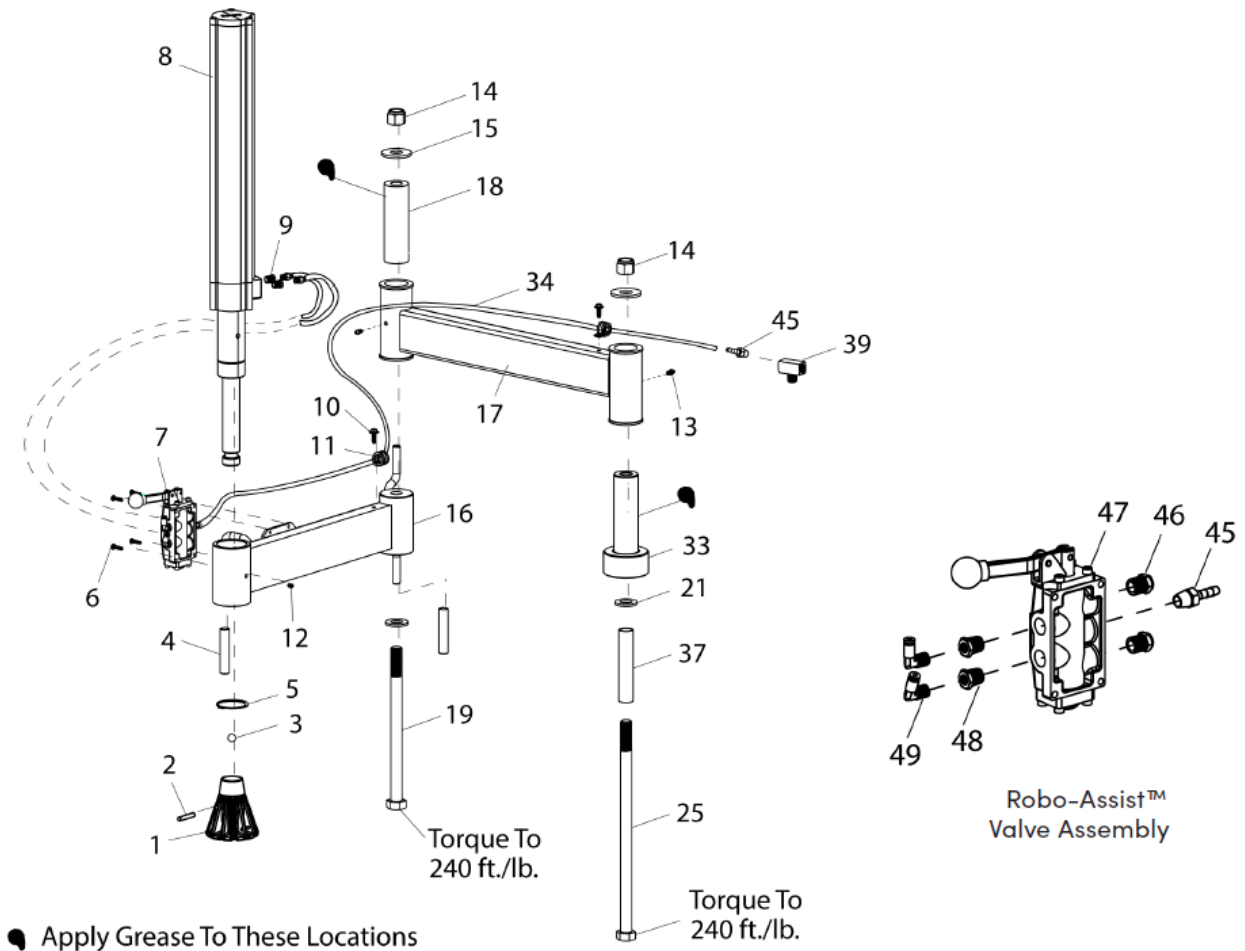

ITEM	PART NO.	DESCRIPTION	ITEM	PART NO.	DESCRIPTION
1	85607622	Robo-Assist Foot	25	8183635	3/4-10 x 14-5, HHCS Screw
2	905563	Roll Pin, 1/4 x 1-1/2	33	8184208	Pivot Pin Spacer
3	8301017	Steel Ball, 1/2"	34	*	Hose, Rubber, 1/4, 58" Black
4	7000230	Handle Grip, 1/2 x 3	35	*	Plastic Tube, 1/8 x 6"
5	8183637	2" Ext. Retaining Ring	37	85607633	Swing Arm Sleeve
6	8181983	10-24 x 3/4 SBHCS Screw	39	85610425	1/4 NPTM x 1/4 F Straight Fitting
7	***	Robo-Assist Valve Assembly	45	8000378	Brass Straight Fitting, 1/4 NPT
8	85608883	2.5" Cylinder Assembly	46	8105615	Small Muffler
9	8181996	1/8 NPT x 1/8 Tube St. Fitting	47	8185585	3 Position Valve
10	8106301	1/4-20 x 3/4" HWHST Screw	48	8109481	RDCR Fitting, 1/4 NPT x 1/8 NPT
11	8182044	Neoprene Cushion Clamp	49	8181997	Male Elbow, 1/8 NPT x 1/8"
12	8183649	1/4-20 x 5/16" Soc Hd Set Screw			
13	8184226	1/4-28 Grease Fitting			
14	8100957	3/4-10 Hex Nylock Lock Nut			
15	8100994	3/4" Flat Washer x 2" OD			
16	85610458	Front Arm Weldment			
17	85610460	Rear Arm Weldment			
18	8181038	Swing Arm Pivot Pin			
19	8183703	3/4-10 x 10-1/2" Hex HD Cap Srw			
21	8182457	Flat Washer, 13/16 ID x 1-1/2 OD			

* Hose Reels		
LENGTH	PART NO.	DESCRIPTION
50-ft.	85000375	1/4" ID x 1/2 OD Black Rubber Hose
50-ft.	85000376	1/8" OD x 0.25 Plastic Tube

Cylinder Assemblies

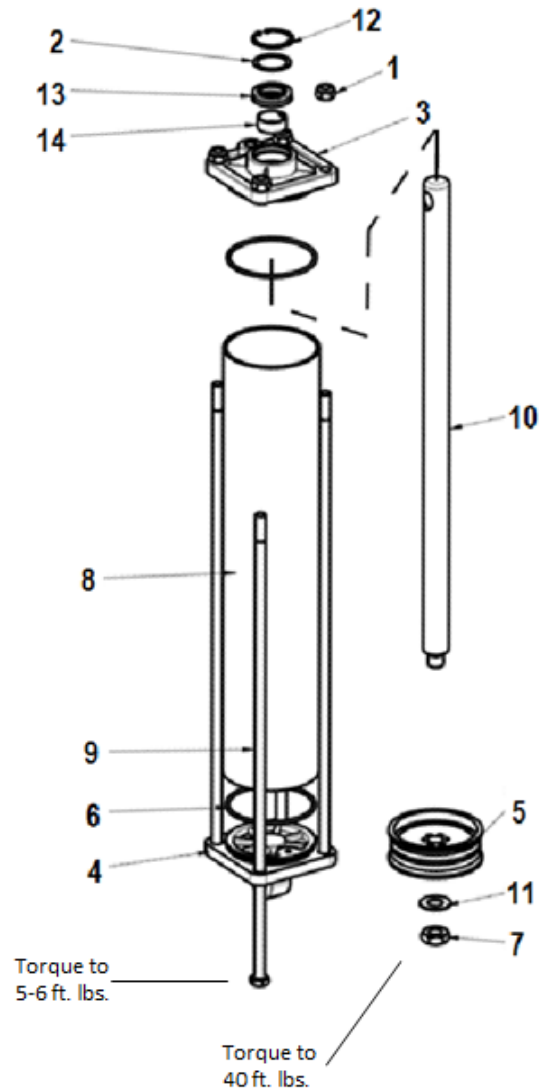
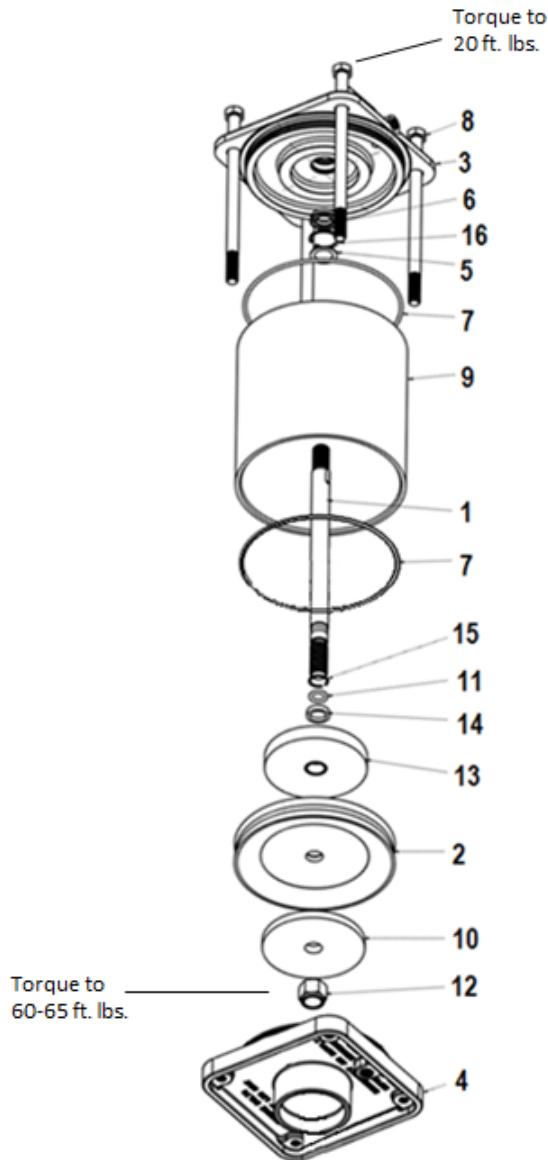

Bead Loosener Cylinder Assembly - 8183326

Item No	Part No.	Description
1	8182685	B.L. Cylinder Shaft
2	8110884	7" B.L. Cyl Piston
3	8183329	B.L. Cyl Top Cap
4	8183327	B.L. Cyl Bottom Cap
5	8182720	Seal Washer
6	8423349	Cylinder Seal
7	8183305	2-261 Seal O-Ring
8	8110890	½ x 13 x 9" Hex Bolt, Tie Bolt
9	8182568	7" B.L. Cyl. Sleeve Barrel
10	8181860	B.L. Cyl Lower Washer
11	85607881	O-Ring Seal
12	8182016	¾-10 Lock Nut
13	8181863	B.L. Cyl Upper Washer
14	8182707	Special Washer
15	8182705	Retaining Ring
16	8182706	Retaining Ring

Table Top Cylinder Assembly - 85607010

Item No	Part No.	Description
1	8185032	M8 x 1.25 Hex Lock Nut
2	8185033	Steel Shim
3	81856581	3" Top Cylinder Cap
4	81856582	3" Bottom Cylinder Cap
5	81856584	Piston
6	81856588	2.5" O-Ring Seal
7	85606860	M12 x 1.75 Jam Nut
8	85607011	3" Cylinder Sleeve
9	85607012	M8 x 1.25 x 400, Tie Bolt
10	85607013	Piston Shaft
11	85607540	M12 Plain Washer
12	85607667	Internal Retaining Ring
13	85607669	TT Cylinder Scraper Seal
14	85607972	Nyliner Sleeve Bearing

Pneumatic Diagram

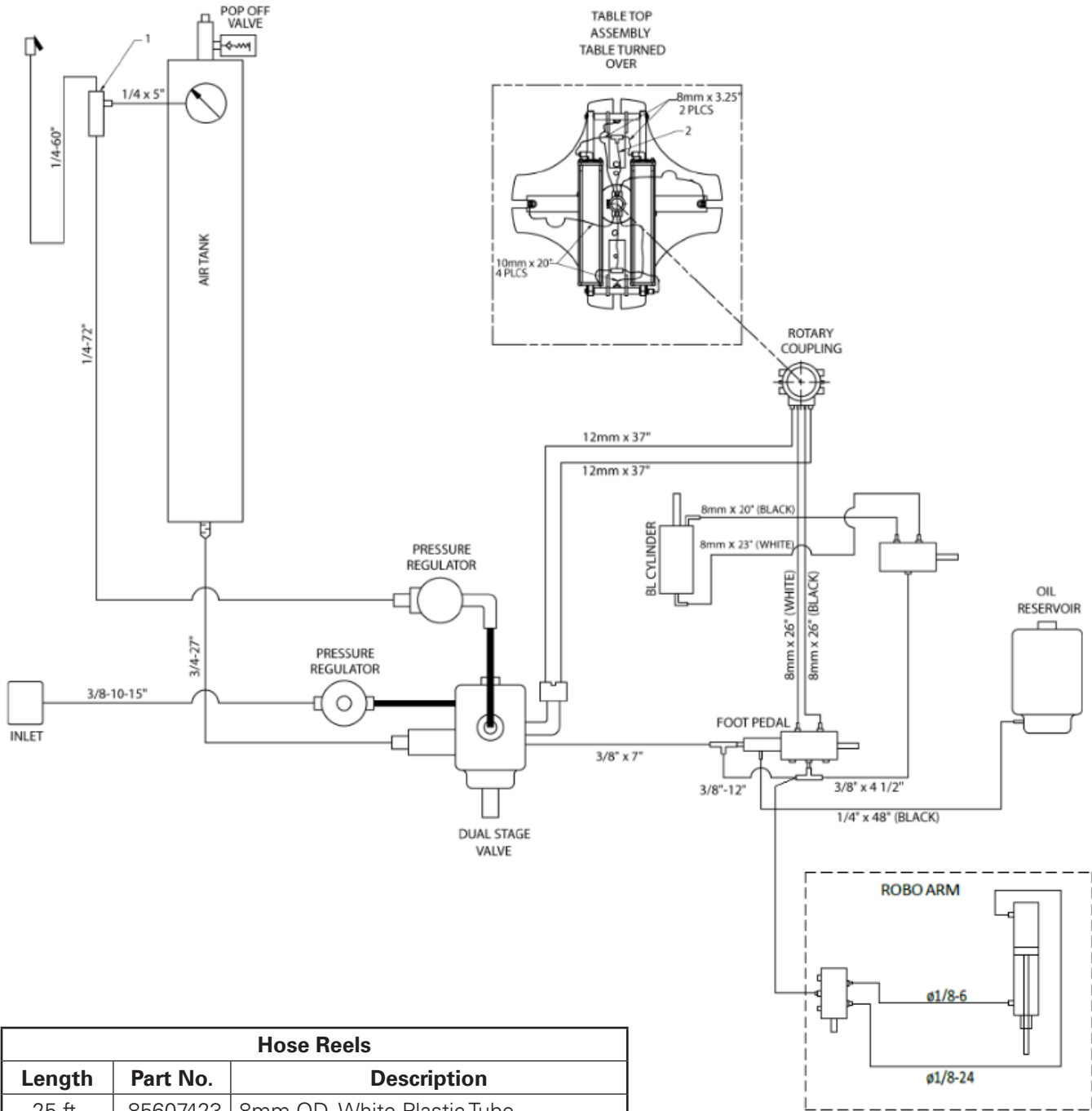

Hose Reels		
Length	Part No.	Description
25-ft.	85607423	8mm OD, White Plastic Tube
80-ft.	85000380	10mm OD, Black Plastic Tube
25-ft.	85607426	12mm OD, Plastic Tube
80-ft.	85000378	3/4 ID x 1.156 OD, Black Rubber Hose
50-ft.	85000377	3/8 ID x 11/16 OD, Black Rubber Hose
50-ft.	85000375	1/4 ID x 1/2 OD, Black Rubber Hose
Item No.	Part No.	Description
1	85607311	1/4 BRB Tee Fitting
2	85607882	8mm OD, Plastic Coil Hose Assy.

Cable Assemblies and Circuit Breakers

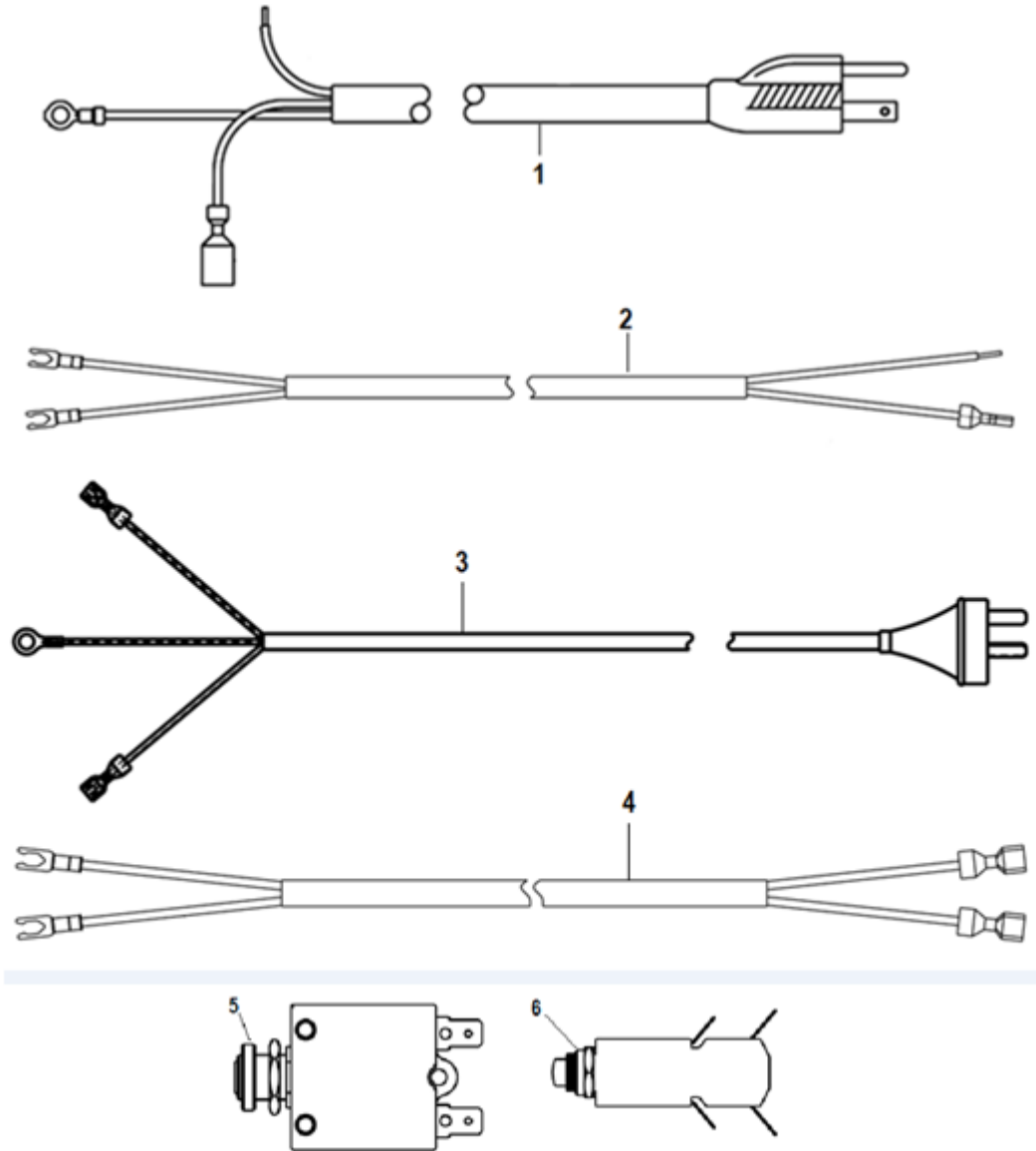

Item No	Part No.	Description
1	85610349	115 V Power Cord Assy.
2	85610400	115 V Switch Breaker Cable
3	85609034	Australian Power Cord Assy.
4	85609029	220 V Switch Breaker Cable
5	8181587	115 V Circuit Breaker, 15 A
6	85007776	240 V Circuit Breaker, 15 A

Electrical Schematics

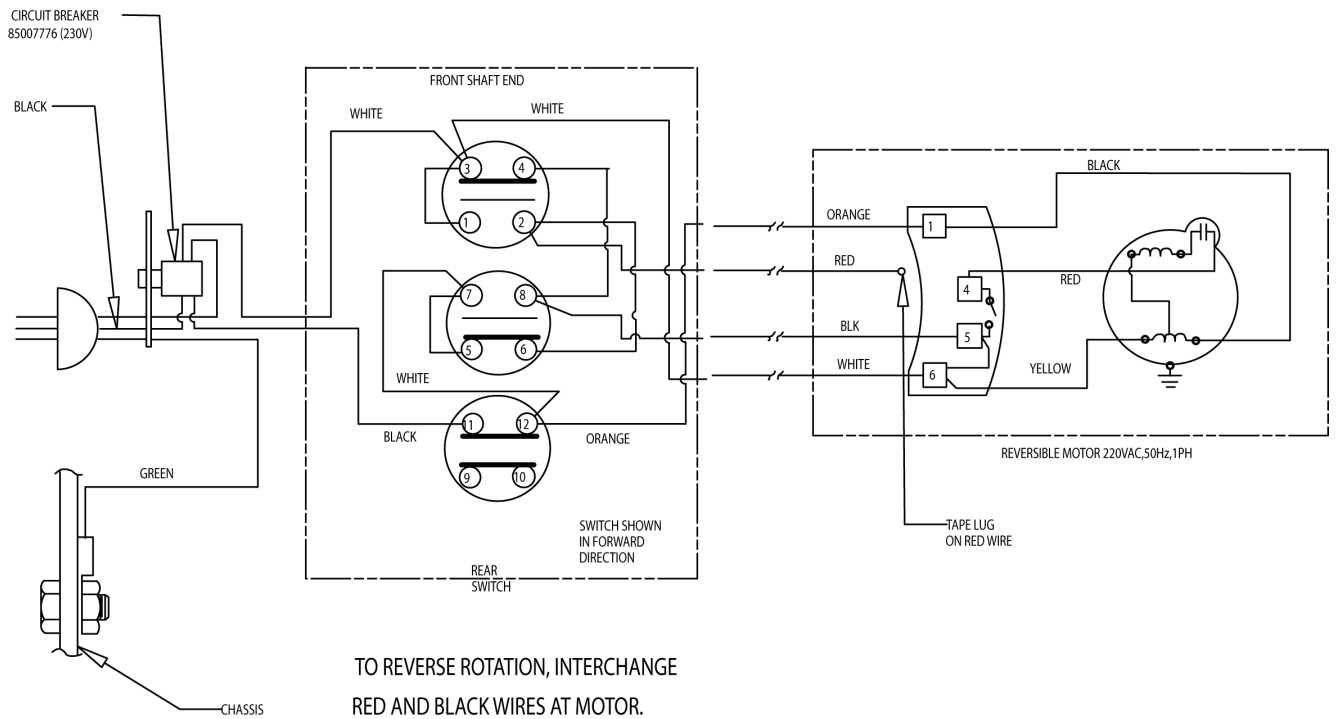
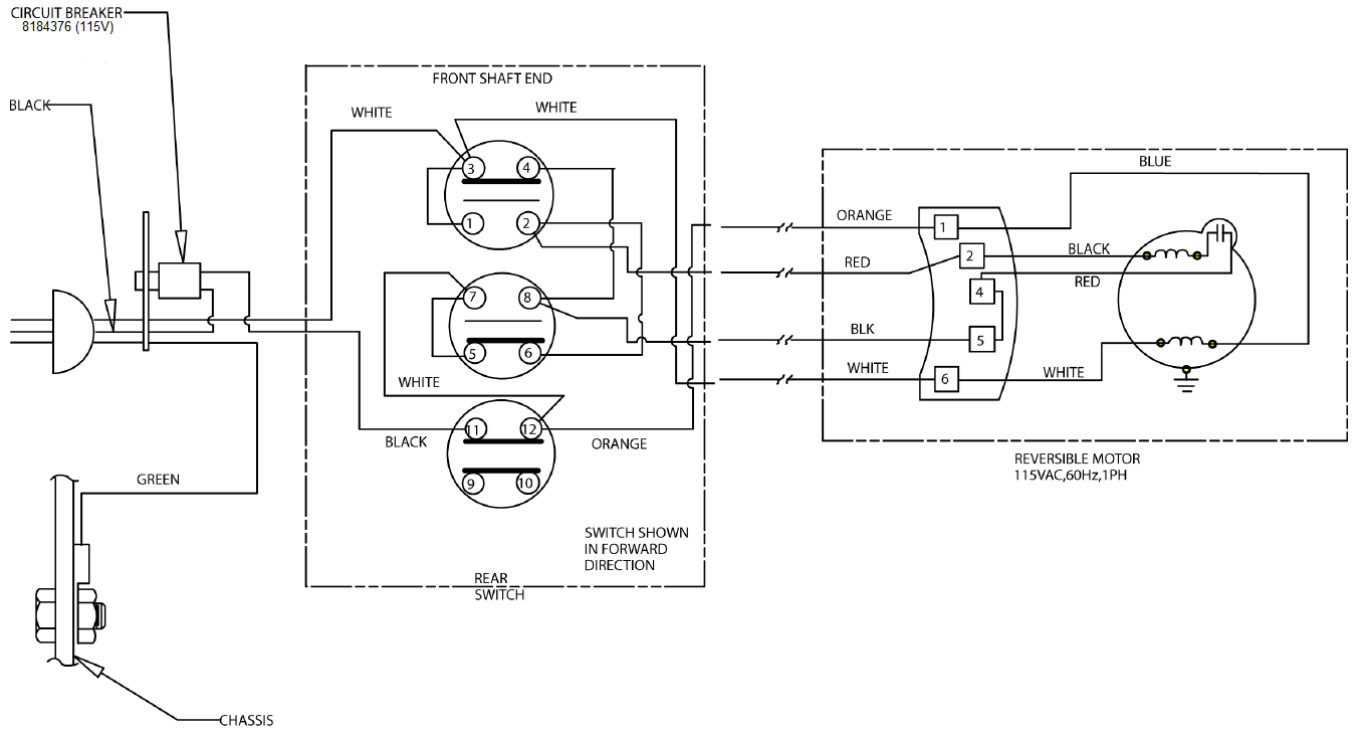

General Maintenance

The unit should be checked monthly for loose hardware, especially at the table top clamps and clamp cylinders, pedal linkages, tower stop, and bead loosener arm area. Special attention should be given to the duckhead set screws.

Clean the table top, clamps, duckhead and other shiny metal surfaces with a vaporizing solvent. Painted surfaces can be cleaned with mild soap & water.



Do not use brake cleaning solvents. Do not allow water to accumulate inside, under or around the tire changer.

Torque Specification Chart Bead Loosener Cylinder

Tie Bolts.....	20 ft. lb.
Piston Nut to Shaft	60-65 ft. lb.
Shaft to Washer (if equipped).....	45 ft. lb.

Table Top Cylinder

Tie Bolts.....	5-6 ft. lb.
Piston Nut to Shaft	40 ft. lb.

Table Top Sub Assembly

Clamps to Carriers (if equipped)	40-45 ft. lb.
Pivot Arm Bolts	40-45 ft. lb.
Pivot Block to Table.....	14-18 ft. lb.
Table to Spider	20-35 ft. lb.
Spider to Transmission.....	175 ft. lb.
Transmission to Chassis.....	20-25 ft. lb.
Foot Pedal to Chassis.....	4-8 ft. lb.
Motor Mount Bolts	10-20 ft. lb.
Duck Head to Shaft.....	20-26 ft. lb.
Robo / Swing Arm Bolt.....	240 ft. lb.



Parts referenced have torque adjustments shown beside parts.

Lubrication Points

Operation & Ref. #	Lubricant	Wkly	Bi-Wkly	Monthly
B. L. Arm Pivot	SAE 30 OIL	X		
B. L. Shoe Pivot	SAE 30 OIL	X		
B. L. Arm Cylinder Pin	SAE 30 OIL	X		
B.L. Cylinder Clevis Pin	SAE 30 OIL	X		
Table Top	SAE 30 OIL	X		
T. T. Clamp Carriers	AGMA 1 or 2 Grease			X
T.T. Pivot Plate	SAE 30 OIL		X	
T. T. Pivot Block	SAE 30 OIL		X	
Filter/Lubricator	Air Tool Oil	X		
Transmission	SAE 80/90 Gear Oil	X		
Vertical Slide Bar	Chassis Grease			X
Lock Plate Lift Pin	SAE 30 OIL		X	
Lock Handle Lift Cam	SAE 30 OIL		X	
Robo-Arm® Cyl. Shaft	SAE 30 OIL			X
Robo-Arm® Pivot Joints	Chassis Grease			X
Foot Pedal Linkage Rod	Chassis Grease			X

Oil Injector Maintenance



The oil injector typically requires annual service. The oil level in the oil reservoir tank should be checked regularly.

- 1.** Add oil to the oil reservoir tank if the fluid level in the tank is below a quarter full.
- 2.** Remove the cap from the oil reservoir tank and add Chevron Regal® R & O 32 oil to the full line.
- 3.** Replace the cap and clean up any spilled oil.

Important: If the hose between the reservoir and injector is ever empty of oil, an air lock will form. After filling the reservoir tank, the line must be bled of air at the injector connection as follows:

1. Remove the side panel and locate the oil injector.
2. Loosen the bleeder plug until oil drips from the plug.
3. Retighten bleeder plug.
4. Cycle the clamp valve a few times checking for oil and air leaks.
5. Test the machine for full function before returning the machine to operation.

Transmission Lubrication

1. While wearing rubber gloves, remove the fill port plastic plug and inserting your finger to check the fluid level.

2. If your gloved finger touches the oil, the transmission is properly filled.

3. If your glove remains dry, add a high quality SAE 80/90 gear lubricant.

4. Repeat steps 2 & 3 to recheck the fluid level.

5. Reinstall the fill port plastic plug.

Air Gauge Check

1. Inflate a standard 15" passenger car tire/wheel assembly to 32 PSI.

2. Use a high quality stick-type pressure gauge to verify the pressure.

3. Attach the tire changer's inflation hose to the valve stem and check the pressure reading on the air gauge.

4. If it does not read 32 PSI, replace the gauge.

Danger, Warning, Caution, and Instructional Decals

1. Ensure that cleaning of these important decals is a part of your regular maintenance routine.

2. If they are damaged or illegible, replace them immediately.

3. Your safety and the safety of others are involved!

Decal Layout

