

BASELINE™

Rim Clamp® Tire Changers

For servicing single piece automotive and most light truck tire/wheel assemblies.



Model 300 Shown



Model 500 Shown

See
RIM Safety page 3
★ Operating
Instructions
on page 8.

Safety Instructions
Set Up Instructions
Operation Instructions
Maintenance Instructions

READ these instructions before placing unit in service. **KEEP** these and other materials delivered with the unit in a binder near the machine for ease of reference by supervisors and operators.

Table of Contents

Tire Specifications Diagram	1
Safety Instructions	2
Owner’s Responsibility	2
Operator Protective Equipment	2
Definitions of Hazard Levels	2
Safety Notices and Decals	3
Remember R.I.M.	3
Set Up Instructions	4
Location	4
Workspace Requirements	4
Air Source	5
Electrical Source	5
Floor Mounting	5
Principal Operating Parts	6
Know Your Unit	6
Operation Instructions	8
Bead Loosening and Demounting	8
Mounting	12
Inflation	14
Bead Sealing	15
Bead Seating	16
Inflation	17
Stages of Inflation on a Conventional Tire and Rim	18
Bead Sealing	18
Bead Seating	18
Inflation	18
Mismatched Tires and Wheels	19
Operating Instructions (using Robo-Assist™ Helper Arm)	20
Bead Loosening and Demounting (using Robo-Assist™ Helper Arm)	20
Mounting (using Robo-Assist™ Helper Arm)	21
Tube Type Tires	22
Mounting	22
Demounting	22
Maintenance Instructions	23
Mount/Demount Tool Cleaning	24
Mount/Demount Tool Adjustment	24
Robo-Assist® Helper Arm Maintenance	24
Pressure Regulator Maintenance	25
Oil Injector Maintenance	25

NOTICE



Read entire manual
before assembling,
installing, operating,
or servicing this
equipment.

Duckhead® and Rim Clamp® are registered trademarks owned by Hennessy Industries, Inc.

Baseline™ and Robo-Assist™ are trademarks owned by Hennessy Industries, Inc.

Regal® is a registered trademark owned by Chevron Intellectual Property LLC.

Tire Specifications Diagram

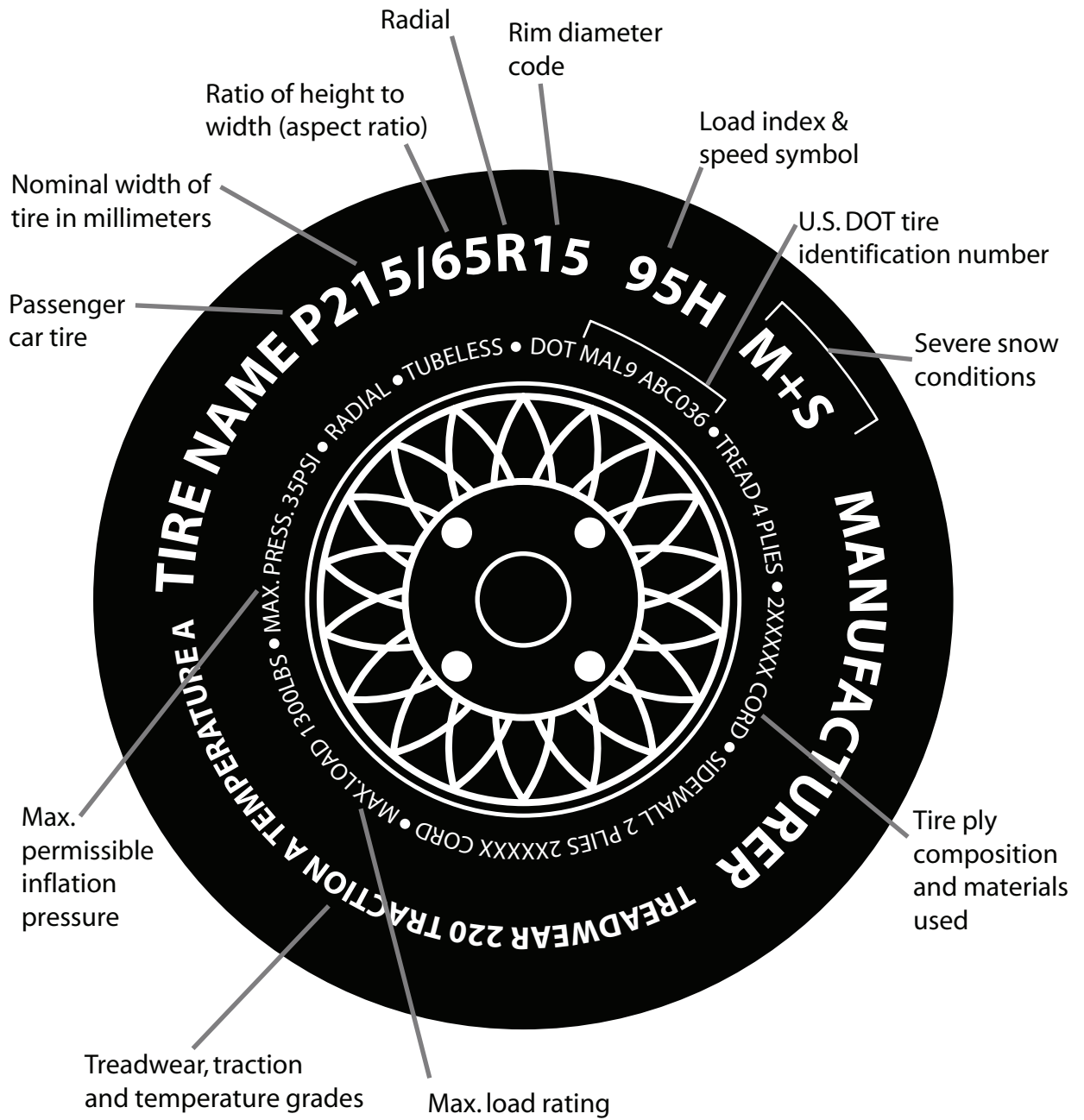

Safety Instructions

Owner's Responsibility

To maintain machine and user safety, the responsibility of the owner is to read and follow these instructions:

- Follow all installation instructions.
- Make sure installation conforms to all applicable Local, State, and Federal Codes, Rules, and Regulations; such as State and Federal OSHA Regulations and Electrical Codes.
- Carefully check the unit for correct initial function.
- Read and follow the safety instructions. Keep them readily available for machine operators.
- Make certain all operators are properly trained, know how to safely and correctly operate the unit, and are properly supervised.
- Allow unit operation only with all parts in place and operating safely.
- Carefully inspect the unit on a regular basis and perform all maintenance as required.
- Service and maintain the unit only with authorized or approved replacement parts.
- Keep all instructions permanently with the unit and all decals/labels/notices on the unit clean and visible.
- Do not override safety features.

Operator Protective Equipment

Personal protective equipment helps make tire servicing safer. However, equipment does not take the place of safe operating practices. Always wear durable work clothing during tire service activity. Loose fitting clothing should be avoided. Tight fitting leather gloves are recommended to protect operator's hands when handling worn tires and wheels. Sturdy leather work shoes with steel toes and oil resistant soles should be used by tire service personnel to help prevent injury in typical shop activities. Eye protection is essential during tire service activity. Safety glasses with side shields, goggles, or face shields are acceptable. Back belts provide support during lifting activities and are also helpful in providing operator protection. Consideration should also be given to the use of hearing protection if tire service activity is performed in an enclosed area, or if noise levels are high.

Definitions of Hazard Levels

Identify the hazard levels used in this manual with the following definitions and signal words:

DANGER

Watch for this symbol:



It Means: Immediate hazards, which will result in severe personal injury or death.

WARNING

Watch for this symbol:



It Means: Hazards or unsafe practices, which could result in severe personal injury or death.

CAUTION

Watch for this symbol:



It Means: Hazards or unsafe practices, which may result in minor personal injury or product or property damage.



Watch for this symbol! It means BE ALERT! Your safety, or the safety of others, is involved!

Safety Notices and Decals



Failure to follow danger, warning, and caution instructions may lead to serious personal injury or death to operator or bystander or damage to property. Do not operate this machine until you read and understand all the dangers, warnings and cautions in this manual. For additional copies of either, or further information, contact:

Hennessy Industries, Inc.
1601 JP Hennessy Drive
LaVergne, TN 37086
(615) 641-7533 or (800) 688-6359
www.baselinegarage.com



For additional information contact:

Rubber Manufacturers Association
1400 K Street N. W., Suite 900
Washington, DC 20005
(202) 682-4800
www.rma.org

Tire Guides, Inc.
The Tire Information Center
1101-6 South Rogers Circle
Boca Raton, FL 33487-2795
(561) 997-9229
www.tireguides.com



Do It Now!

Make sure the instruction and warning decal is clean and clearly visible to operator.

Remember R.I.M.

Three Simple Steps To Help Keep Shops Safe

READ

INSPECT

MOUNT

R.I.M. is a training program developed by Hennessy Industries to help keep tire technicians safe. By following the basic principles of R.I.M., technicians can avoid situations that can cause catastrophic accidents like tire explosions.

R.I.M. stands for read, inspect, and mount:

Read the tire size on a new tire before mounting to make sure it is the proper size for the wheel.

Inspect the wheel for cracks, rust, and or other damage that could cause an unsafe situation.

Mount the tire safely, making sure not to put any part of your body over the tire during inflation.

The most serious of possible accidents is a tire explosion. This is often caused by a tire/rim mismatch.

If a tire explodes on a tire changer, pressure causes it to fly straight up at tremendous speed. If a technician is standing over the tire, he can be seriously injured or killed.



Set Up Instructions



Proper unit installation is necessary for safe use and efficient operation. Proper installation also helps protect the unit from damage and makes service easier. Always place safety poster and instructions near the unit.

Location

Select a location using the drawings below. The area should provide the operator with enough space to use the equipment in a safe manner. The area selected should be well lit, easy to clean and should be away from oil, grease, brake lathe chips, etc. Avoid areas where bystanders and customers may be present.

Workspace Requirements

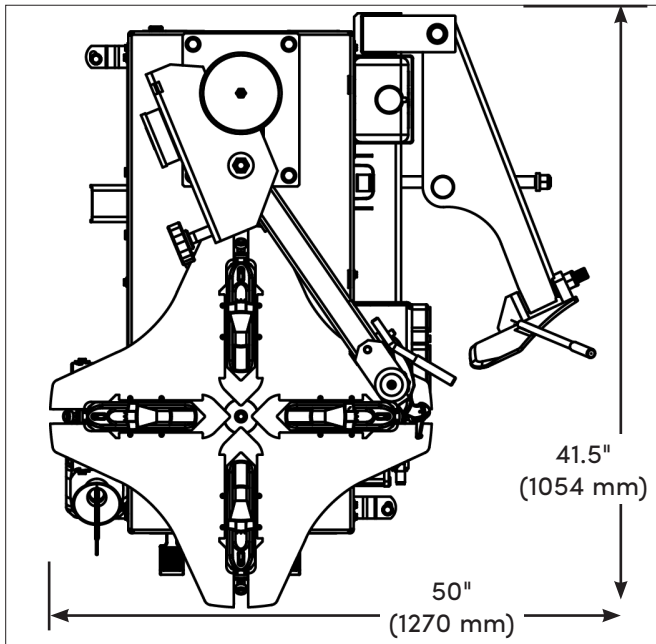

Figure 1 - Work Space Requirements

Tower Installation



STAY CLEAR OF MOVING PARTS when reconnecting the unit to the air supply. The position of control valves may have changed during the servicing of the machine.



Be careful of pinch point at swing arm spring.

Tools Required:



Screw Driver

14 mm Open-ended Wrench

19 mm Open-ended Wrench

24 mm Open-ended Wrench

1. Carefully remove carton and packaging from unit.
2. Using a 14 mm wrench, remove shipping bolts holding tower, swing arm and chassis to the pallet.
3. Using a 19 mm wrench, remove the four bolts and washers from the chassis; reserving the bolts and washers.
4. With the aid of a helper holding the tower, connect hose from chassis to tower barb fitting (figure 2). Position and tighten hose clamp.
5. Use reserved bolts and washers to attach tower to chassis (figure 2). Torque to 15 - 20 ft. lbs.

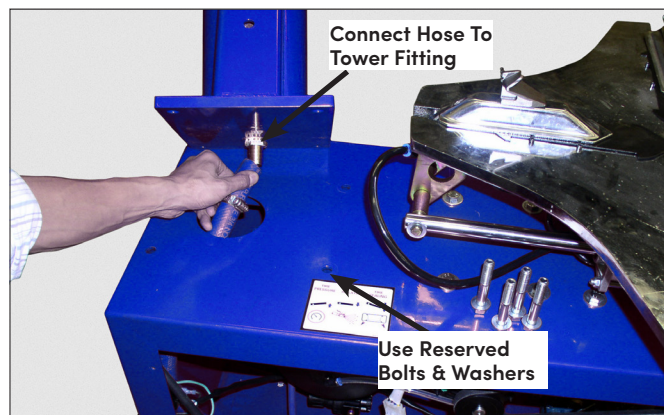

Figure 2 - Assemble tower onto chassis.

6. Remove swing arm bolt, washers and nut from tower. Then, with the aid of a helper, position and attach swing arm using bolt, washers and nut just removed (figure 3). Torque to 240 ft. lb.

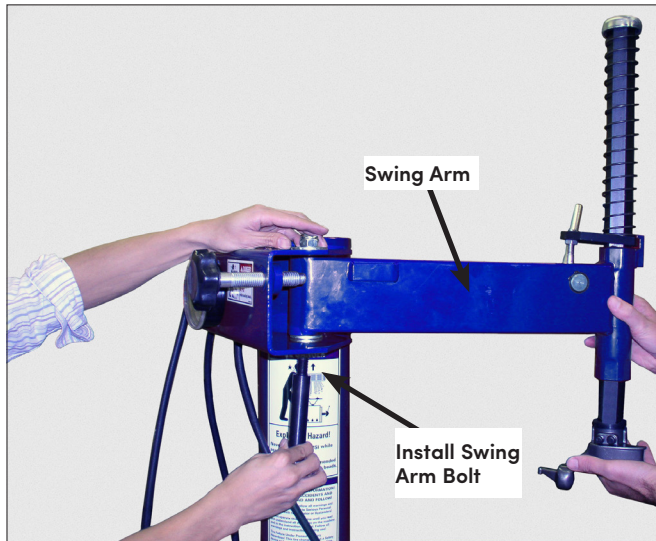

Figure 3 - Install swing arm onto tower.

7. Install air line and/or plug into power supply. Test functionality (oil injector, pressure gauge function, etc.).

Air Source

The model 300 and model 500 require a 5 CFM air source at 120 PSI. The operating pressure range is between 110 PSI and 175 PSI at the machine.

The unit is furnished with a 1/4" pipe thread male fitting for easy connection. This connection is located on the right side of the rear of the machine. A 1/4" ID hose (or pipe) for connection to the machine is satisfactory. Sufficient air pressure ensures good performance.

Electrical Source

Electrical models require power as follows:

115 V, 60 Hz, 15 A, 1 ph. power supply

220 V, 50/60 Hz, 15 A, 1 ph. power supply (Export)

Refer to the caution decal that is located by the unit's power cord.

Refer to the serial tag located on the lower part of the machine for specific electrical requirements for the unit. Have a licensed electrical technician perform any necessary changes to the power source before plugging in the unit. The electrical source must have a solid connection (less than 1 ohm) between ground and building ground.

Floor Mounting

As Hennessy can not be certain of the environment and conditions of the locations where the equipment will be installed, it is recommended that the safety manager review the shop floor conditions and local regulatory practices to determine if bolting of the equipment to the shop floor is necessary or advisable.

Principal Operating Parts

Do It Now!



Now is a good time to contact product service (800-688-6359) to start warranty, otherwise warranty starts at time of shipment.

Know Your Unit

Compare this illustration with the unit before placing it into service. Maximum performance and safety will be obtained only when all persons using the unit are fully trained in its parts and operation. Each user should learn the function and location, of all controls.

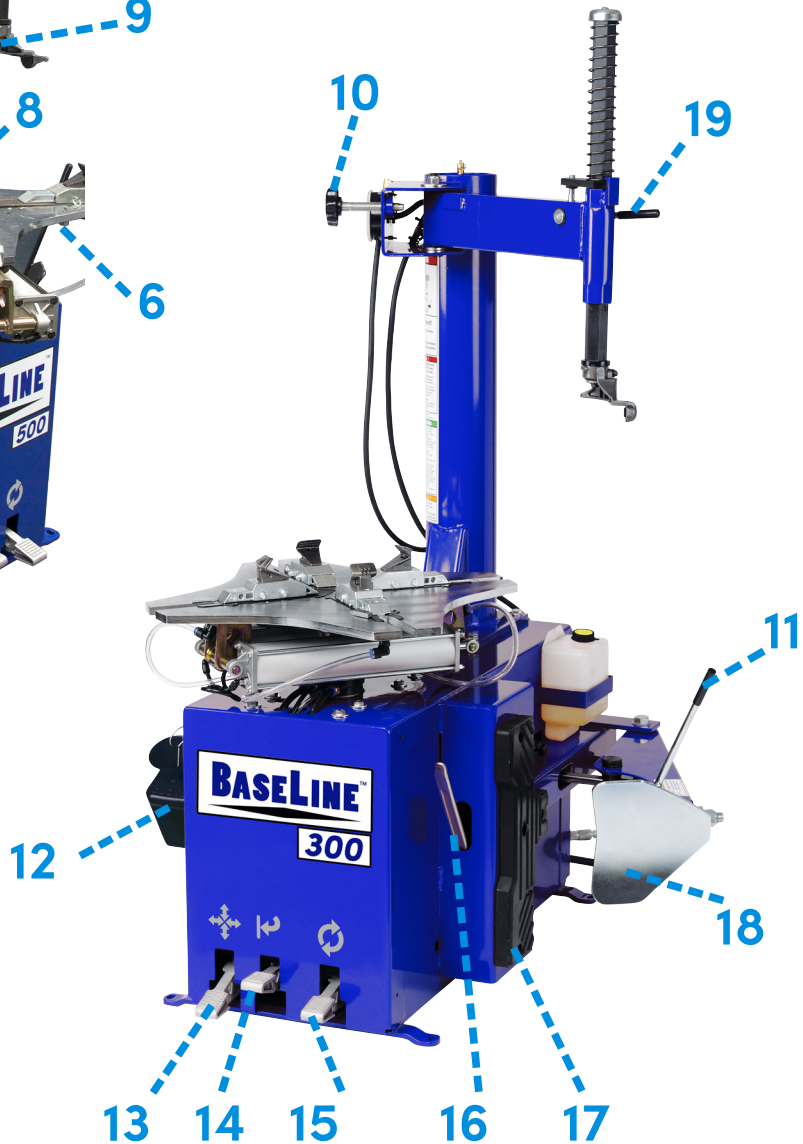
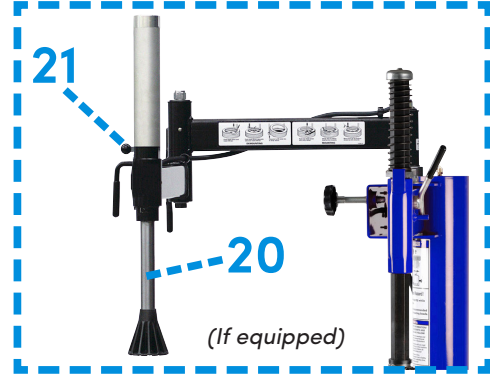
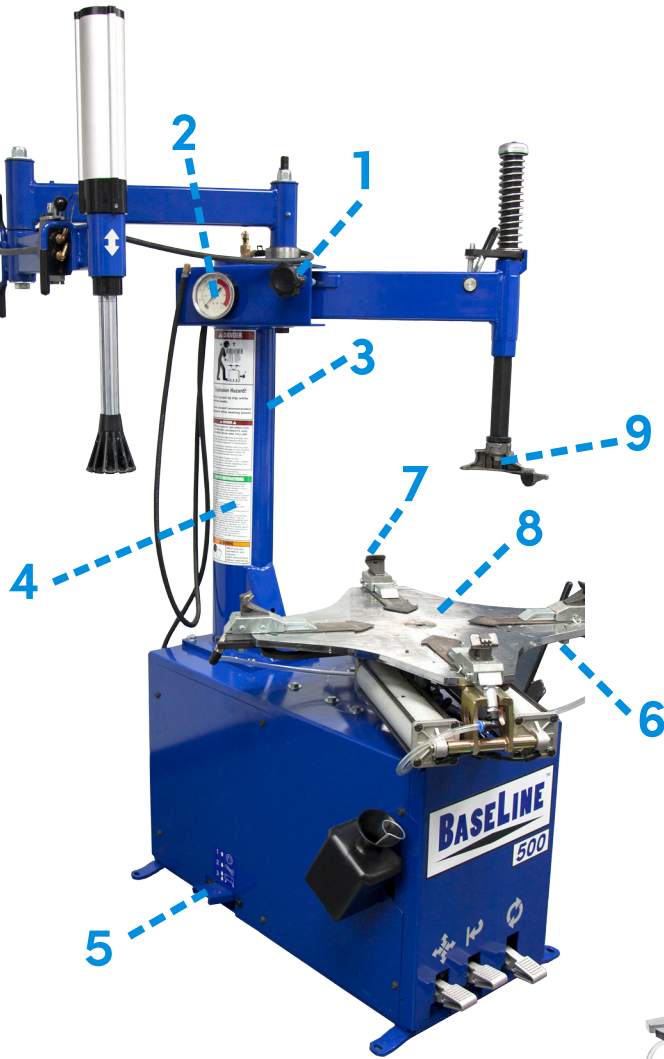



Replace any damaged or missing safety decals. They are available from Hennessy Industries, Inc., (800) 688-6359.

1 Pressure Safety Valve — The high pressure safety valve is set to exhaust at line pressures above 185 PSI.

2 Air Inflation Gauge — Registers tire pressure when clip-on chuck is attached to tire valve stem and inflation pedal is released.

3 Tower — Support for horizontal and vertical slides, also air storage tank.

4 Important Safety Decal — Important safety information for the operator. DO NOT obstruct with tire stickers or other materials.

5 Inflation Pedal — Three-position pedal that allows inflation of tires through air hose and clip-on chuck.

6 Bead Sealing Nozzles — Expands tire sidewall to bead seat area of rim to seal tire to rim and allow inflation.

7 Clamps — Holds wheel to table top for tire changing. Position outward to allow outside clamping of wheels.

8 Table Top — Rotating chuck for tire changing.

9 DuckHead® Mount/Demount Tool — Mounts and demounts tire from wheel.

10 Swing Arm Adjustment Knob — Adjusts swing arm/vertical slide assembly for proper horizontal positioning of mount/demount head.

11 Bead Loosener Handle — Controls operation of bead loosener shoe.

12 Lube Bottle — Dispenser for rubber lubricant.

13 Clamp Control Pedal — Three-position pedal that opens, holds or closes rim clamps.

14 Bead Loosener Control Pedal — Controls operation of bead loosener shoe.

15 Table Top Pedal — Three-position pedal that controls rotation of table top (forward, off, reverse).

16 Bead Lifting Tool — Used to lift and position tire bead correctly on Duckhead® mount/demount tool.

17 Tire Bumper Guards — Provides protective surface when bead loosening tires.

18 Bead Loosener Shoe — Pivoting shoe for loosening tire beads.

19 Vertical Slide Locking Handle — Locks and unlocks vertical slide and sets correct vertical position to maintain tool/wheel clearance.

20 Robo-Assist™ Helper Arm — Provides extra leverage when mounting/demounting tires.

21 Helper Arm Control Valve — Controls vertical movement of helper arm cylinder.

Operation Instructions

This unit must be properly operated and properly maintained to help avoid accidents that could damage the unit and injure the operator or bystanders. This section of the Operation Instructions manual reviews the basic operations and use of controls. These instructions should be reviewed with all employees before they are allowed to work with the machine. Keep these instructions near the machine for easy reference.

Bead Loosening and Demounting



This machine may operate differently from machines you have previously operated. Practice with a regular steel wheel and tire combination to familiarize yourself with the machine's operation and function.

TECH TIP Remember to remove all weights from both sides of the wheel. Weights left on backside of wheel may cause the wheel to be clamped unlevelled. This may result in the Duckhead® mount/demount tool contacting the rim causing scratches. On alloy wheels, always rotate the wheel one turn after setting the mount/demount tool to insure proper wheel chucking.

TECH TIP Always review with the owner any nicks and scratches on expensive wheel and tire combinations prior to servicing.



Loosening the beads on a partially or fully inflated tire is unsafe and causes excess movement and friction against the bumper pads and excessive wear on pivots. Deflate the tire completely to prolong the life of your machine.

1. Deflate the tire completely by removing the valve core from the valve stem (figure 4). Be cautious and do not smoke as a flammable gas could have been introduced into the tire at some time.



Figure 4 - Remove Valve Core to Deflate Tire



Tires are always installed and removed from the rim's narrow side.

TECH TIP Always loosen the bead on the narrow side of the wheel's drop center first (tire removed in figure 5 for clarity).

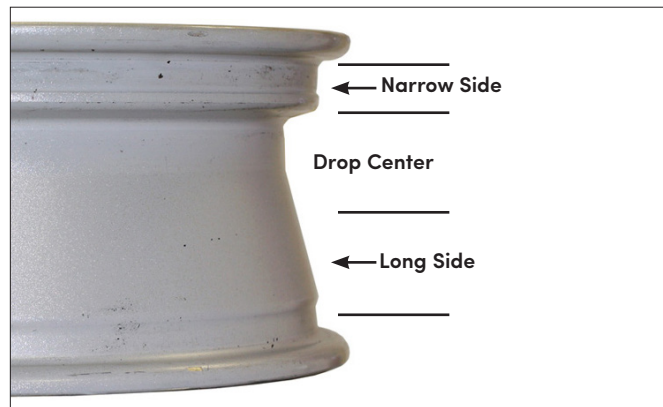

Figure 5 - Determine Narrow Side of Wheel

TECH TIP The clamps on the table top may extend beyond the table top itself. To avoid damaging the clamps, move them to their full inward position before positioning a tire for bead loosening.

TECH TIP Use extra care in positioning the bead loosener shoe on larger wheels/tires, and on alloy wheels. Make sure the shoe rests next to but not on the rim, and not on the tire sidewall.

2. Pull the bead loosener shoe away from the machine and roll wheel into position. The valve stem should be in the 2 o'clock position to accommodate a possible asymmetric safety hump type rim. Position the bead loosener shoe against the tire next to, but not on, the rim. Press the bead loosener foot pedal to actuate the shoe and loosen the bead. It may be necessary to loosen the bead in multiple locations around the tire (figure 6).



Figure 6 - Position Tire and Bead Loosener Shoe

3. Turn the wheel around and repeat loosening procedure on the other side of the wheel (figure 7). This should be the long side of the drop center (figure 5).



Figure 7 - Position Tire and Bead Loosener Shoe With Wheel Turned Around



It will be easier to outside clamp the wheel to the table top if the long side of the rim is loosened last.

4. Apply tire manufacturer's approved rubber lubricant liberally to entire circumference of both tire beads after loosening (figure 8).



Figure 8 - Apply Rubber Lubricant to Tire Beads

5. Determine the mounting side of the wheel. The mounting side is the narrow side of the drop center. See figure 2 for more information on the drop center.

6. Place tire/wheel assembly on table top with mounting side up (figure 9). Use the clamp control pedal to move the clamps inward (push pedal down) or outward (toggle pedal up). Clamp steel wheels from the inside (clamps push outward against wheel). Clamp mag and custom wheels from the outside (clamps push inward against the outside rim edge).

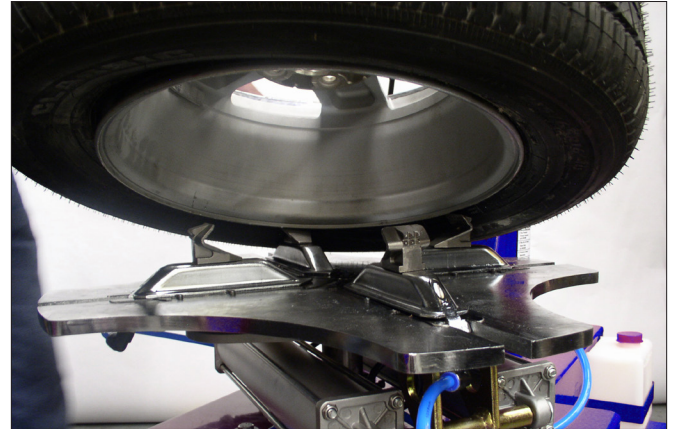

Figure 9 - Place Tire/Wheel Assembly on Table top

7. Move the swing arm into position. Pull the locking handle forward to release the slide. Push down on the top of the vertical slide to move the mount/demount tool into contact with the rim edge. Push the locking handle back and lock the slide into place (figure 10).



Figure 10 - Position Mount/Demount Tool.

8. The mount/demount tool should be in contact with the rim edge. Turn the swing arm adjusting knob to move the mount/demount tool away from the rim 1/8 to 1/4 inch (figure 11)



Figure 11 - Adjust Swing Arm to Position Tool Roller

9. Check metal mount/demount tool positioning. The metal mount/demount tool should be positioned with 3/16 to 1/8 inch clearance between the top of the rim edge and the bot-tom of the tool, and 1/8 to 1/4 inch clearance between the rim edge and the mount/demount tool roller. This clearance will be maintained as long as the locking handle and adjustment knob are not changed. The operator may swing the arm out of the way and back into place again without needing to reposition the tool (when changing a like set of wheels) (figure 12).

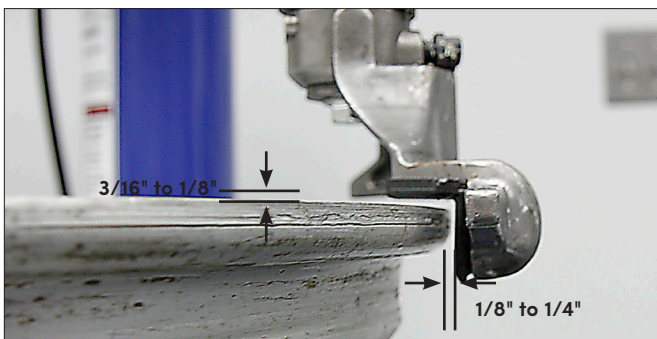

Figure 12 - Proper (Metal) Mount/Demount Tool Position

TECH TIP

The tool clearance may change with machine use and should be inspected often. Failure to maintain the proper clearance may result in damage to the wheel rim and/or tire.

TECH TIP

Normal table top rotation for demounting is clockwise. Depress the table top pedal to rotate this direction. To rotate the table top counter-clockwise, lift the pedal up with your toe.

TECH TIP

Table top rotation can be stopped at any time by removing your foot from the rotation pedal.

CAUTION

At times during the mounting and demounting procedure, the bead lifting tool may encounter resistance and can be thrown. Keep one hand firmly on the tool to avoid possible tool disconnect. Use the reversing feature to back out of jam-ups. A thrown tool can cause injury.

10. Insert the smooth curved end of the bead lifting tool over the forward end of the mount/demount tool and below the top bead of the tire. Lift the bead up and over the knob on the Duckhead® mount/demount tool (figure 13). Also, note the valve stem position to the mount/demount tool. Use your free hand to press down on the tire opposite the mount/demount tool to allow the bead to utilize the drop center area of the rim, this position reduces stresses in the bead and allows an easier bead lift.



Figure 13 - Insert Bead Lifting Tool Below Tire Bead

11. Push the bead lifting tool down towards the wheel to lift the tire bead up and over the knob portion of the mount/demount tool. Hold the bead lifting tool and tire bead in this position (figure 14).



Figure 14 - Lift Tire Bead Over Duckhead® Mount/Demount Tool Knob

12. Depress the table top pedal to rotate the wheel. The Duckhead® mount/demount tool will guide the tire bead up and over the edge of the wheel. Continue rotation until the upper bead is demounted.



Push down on the tire across from the mount/demount tool during table top rotation to utilize the drop center area of the wheel. This reduces the tensional force on the top or first bead



during demount (figure 13).

Figure 15 - Demounting Lower Bead

13. Lift and hold the tire at an angle so that the lower bead is resting in the drop center directly across from the mount/demount tool, and is loose below the mount/demount tool (figure 15). Insert the smooth curved end of the bead lifting tool down over the forward end of the mount/demount tool and below the lower bead. Lift the bead up and over the knob on the mount/demount tool (figure 16).



Figure 16 - Guide Lower Bead Over Tool Knob

14. Depress the table top pedal to rotate the wheel. The mount/demount tool will guide the bead up and over the edge of the wheel. Continue rotation until lower bead is demounted.



With tube-type tires, demount the upper bead and remove the tube before demounting the lower bead.

Mounting

This information must be read and followed carefully to prevent accidents and injuries during mounting.



Attempts to force a bead seat on mismatched tires and wheels can cause the tire to violently explode, causing serious personal injury or death to operator and/or bystanders.



Check tire and wheel carefully before mounting. Make sure the tire bead diameter and wheel diameter match exactly. Consult the Tire Guide and/or Rubber Manufacturer's Association for approved rim widths for tire sizes.



Never mount a damaged tire. Never mount a tire on a rusty or damaged wheel. Damaged tires and/or wheels may explode.



When in doubt do not mount.



Never mount a tire and wheel handed to you by anyone without checking both tire and wheel for damage and to be certain the sizes match. Do not let untrained persons operate tire changer and keep bystanders out of service area.



Forcing the tire onto the rim can cause bead damage. If you damage the tire bead during mounting, STOP!, remove tire and mark it as damaged. Do not mount a damaged tire.

1. Before any mounting, inspect tire for damage and verify size match between tire and wheel (figure 17).



Figure 17 - Verify Size Match Between Tire and Wheel

2. Inspect wheel closely for damage. Clean the wheel and remove any light corrosion or rubber residue (figure 18). Do not attempt to service a heavily corroded wheel, damaged wheel, or bent wheel.

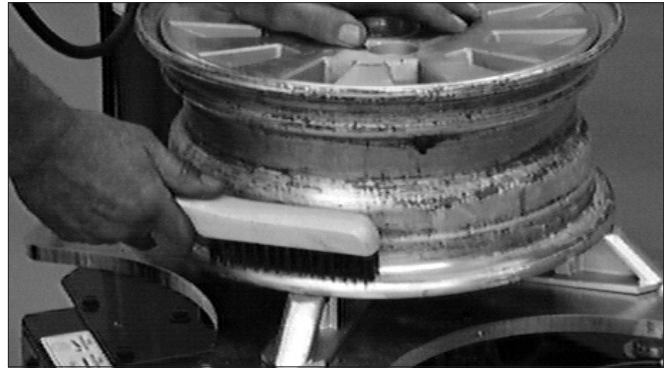

Figure 18 - Inspect and Clean the Wheel

3. Inspect valve stem and replace if necessary. Next lubricate tire beads liberally with tire manufacturer's approved rubber lubricant (figure 19).



Figure 19 - Lubricate Tire Beads Liberally

4. Place tire over wheel and move swing arm into position making sure the valve stem is at the 9 o'clock position in front of bead lock. Position tire so that lower bead is above the rear extension of the mount/demount tool and below the front knob (figure 20).



Figure 20 - Position Tire Against Mount/Demount Tool

5. Depress table top pedal and rotate wheel to mount lower bead. Use drop center of wheel by forcing down on tire just ahead of the mounting tool, and follow as tire rotates. Rotate table top until lower bead is mounted.

6. For top bead installation, rotate the table top until the valve stem is directly across from the Duckhead® mount/demount tool. Lift the upper bead up and over the rear of the mount/demount tool. With your left hand press down on the tire between the mount/demount tool and the valve stem, to hold the tire in the drop center. Depress table top pedal and rotate tire until bead is mounted. Be careful to ensure bead stays in the rim drop center in the area ahead of mount/demount tool (figure 21).



Figure 21 - Mounting Top Bead



If table top rotation stalls, reverse the table top momentarily until tire bead is again loose on the wheel. Reposition tire on Duckhead® mount/demount tool, make sure bead is correctly positioned in drop center of the wheel; then attempt mounting again.



For low profile or stiff sidewall tires, it may be advantageous to use the bead lifting tool to initially hold the upper bead down in the drop center.



For tube type tires, mount lower bead first, move swing arm out, install tube, and then mount upper bead.

Inflation

Tire inflation is performed in three steps: BEAD SEAL, BEAD SEAT, and INFLATION. These steps are explained in detail on page 18. Read the explanation of each step and understand them thoroughly before proceeding.



Tire failure under pressure is hazardous. This tire changer Will Not Restrain Exploding Tires, rims or other related equipment. Inspect tire and wheel carefully for match, wear, damage, or defects before mounting. Always use approved tire bead lubricant during mounting and inflation.



The clip-on chuck allows the operator to keep hands and entire body back from inflating tire. The chuck must be an open/freeflow style with all parts in proper working order.



Check for proper inflation gauge operation. Accurate pressure readings are important to safe tire inflation. Refer to the Operating Maintenance section of this manual for instructions.



If the rim has been clamped from the outside for tire mounting, release the clamps, lift the tire, and move the clamps to the center of the table top.



If the wheel/tire has a diameter larger than 14-inches and is difficult to bead seal, the clamps should be moved to the center of the table top for the bead seal operation.

The inflation pedal, located at the rear of the left side of the machine, controls the flow of air through the inflation hose, and has three positions.



The clip-on chuck on the end of the hose should always be an open/freeflow style with all parts in proper working order.

Position 1 - Tire Pressure – With the inflation hose attached to the tire valve and the pedal in this position, the air gauge will register the air pressure in the tire. Whenever your foot is removed from the pedal, it will return to this position.

Position 2 - Tire Inflation – This is the first activated position. With the inflation hose attached to the tire valve and the pedal in this position, line pressure is allowed to flow through the valve system and into the tire for inflation. Correct tire pressure is not indicated on the gauge in this position.

Position 3 - Bead Sealing – This is the second and last activated position. With the inflation hose attached to the tire valve and the pedal in this position, line pressure is allowed to flow through the valve and to the air-flate bead seal jets on the table top for bead sealing.

1. If the rim has been clamped from the outside for tire mounting, release the clamps, lift the tire, and move the clamps to the center of the table top.

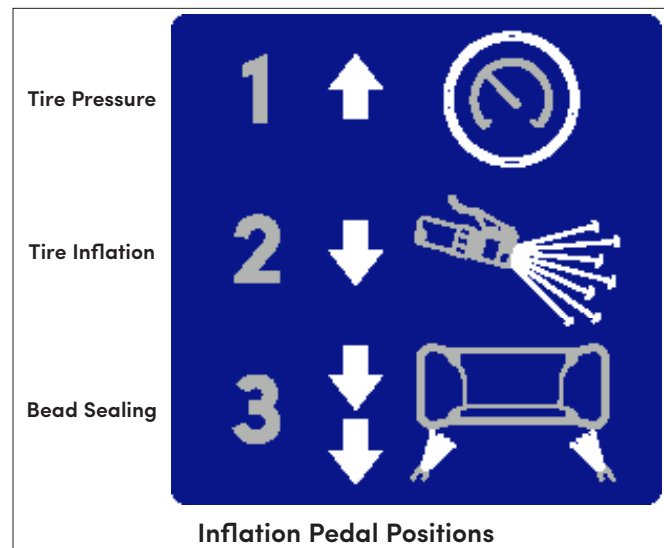

Note the Inflation Pedal Positions (See Above)

CAUTION

Use of bead sealing jets without a tire in place can cause dirt and debris to be blown into the air with enough force to injure operator and/or bystander. Do not use the bead sealing control position to inflate a tire.



This unit is equipped with a pressure regulator to assist the operator with proper tire inflation. The pressure regulator will keep most car and light truck tires from inflating beyond 60 PSI (smaller tires may reach higher pressures). It is the operator's responsibility to follow all instructions and to control inflation pressure as specified in these instructions. Check the function of the pressure regulator regularly and maintain it according to the instructions provided in this manual for safe and proper operation. Do not tamper with or attempt to adjust the pressure regulator. Tires requiring inflation beyond 60 PSI should be inflated in a safety cage.

Bead Sealing

1. Remove the valve core from the valve stem to allow more air flow into the tire to assist with bead seal.
2. Position valve stem in front of operator and connect the inflation hose with the clip-on chuck. Hold tire up against upper edge of the wheel. Be sure tire's top bead does not cover the bottom of the valve stem (figure 22).



Figure 22 - Lift Tire Upwards for Bead Sealing

3. Depress inflation pedal to position 2 and hold about one second to begin air flow through tire valve, then depress pedal to position 3 and hold briefly – less than one full second. The blast of air from the jets will expand tire and seal the beads.
4. Release the inflation pedal and allow it to return to position 1. Verify that both beads are completely sealed to the wheel. Repeat these steps if beads have not sealed. It may be necessary to wait a few seconds for the air storage tank pressure to recover before attempting again.
5. After bead seal is achieved, remove the clip-on chuck and reinstall the valve core. Reattach the clip-on chuck after core is installed.

Bead Seating



NEVER exceed 40 PSI to seat beads while using this tire changer. If more than 40 PSI is permitted by tire manufacturer, **ALWAYS** use safety cage and clip-on chuck. **NEVER** exceed recommended pressure after seating beads. **ALWAYS** keep hands and entire body back from inflating tire.

An exploding tire, wheel, or bead sealing equipment may propel upward and outward with sufficient force to cause serious injury or death to operator or bystander.



Check tire pressure frequently. If operator is unable to obtain bead seat, something is wrong. Deflate tire completely, inspect tire and wheel, correct any problems found, re-lubricate both tire beads, and reattempt bead seal and seat procedures. Follow all safety instructions in this manual and on machine.

1. Once tire pressure is indicated on the air gauge (inflation pedal in position 1; foot removed from pedal), continue to inject air into the tire (inflation pedal position 2) in short intervals. Check the pressure frequently. Stand back during bead seat. Keep hands, arms, and entire body away from tire during this procedure (figure 23).

Tire beads should move outward and “pop” into their bead seat position as pressure inside the tire increases. If this does not happen, a problem exists. Investigate carefully.

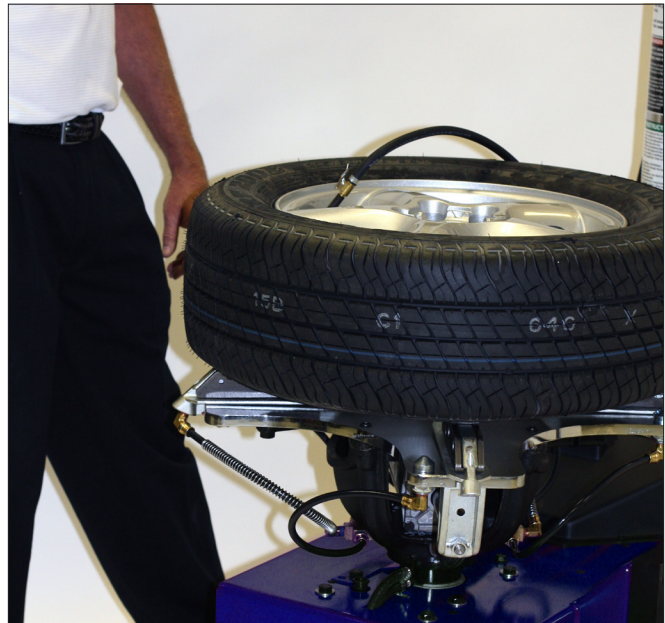

Figure 23 - Stand Back during Bead Seat

Inflation



NEVER exceed tire manufacturer's recommended air pressure. Tires can explode, especially if inflated beyond these limits. Use clip-on air chuck, keep hands, arms and entire body back from inflating tire. Avoid distraction during inflation. Check tire pressure frequently to avoid over inflation. Excessive pressure can cause tires to explode, causing serious injury or death to operator or bystander.



Figure 24 - Do Not Use a Hand-held Style Air Chuck

- 1.** Make sure both beads are seated. When both beads are seated, the tire is ready for inflation.
- 2.** Replace the valve core if it was removed.
- 3.** Depress the inflation pedal to position 2 to inflate the tire. On most tires, the pressure regulator will cease air flow at approximately 60 PSI. On smaller volume tires the pressure may be higher.
- 4.** Important: When inflating tires that require more than 60 PSI, always use a safety cage and air hose with a clip-on air chuck and in-line valve. The air hose must have enough length between the chuck and the operation/in-line valve to allow the operator to stand outside the trajectory.



If you change tires defined as truck tires, they must be inflated per OSHA instructions.

! DANGER

Explosion Hazard
Never exceed 40 PSI
while seating beads.
Remember R.I.M.
(see page 3 and back cover)

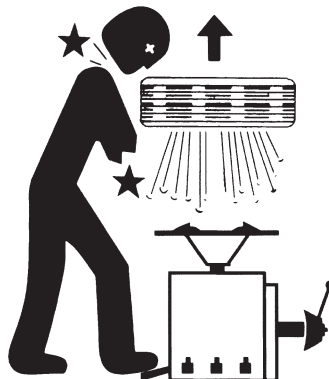

! DANGER

Explosion Hazard
Never inflate tire
above manufacturer's
recommended pressure
after bead is seated.

Stages of Inflation on a Conventional Tire and Rim

Review these descriptions and diagrams carefully. Refer to them as necessary during bead sealing, bead seating, and inflation to verify that you are proceeding properly and safely.

Bead Sealing

Bead sealing is the process of capturing air pressure between the tire and the rim. The tire will usually contain about 1/2 to 2 PSI at initial bead seal.

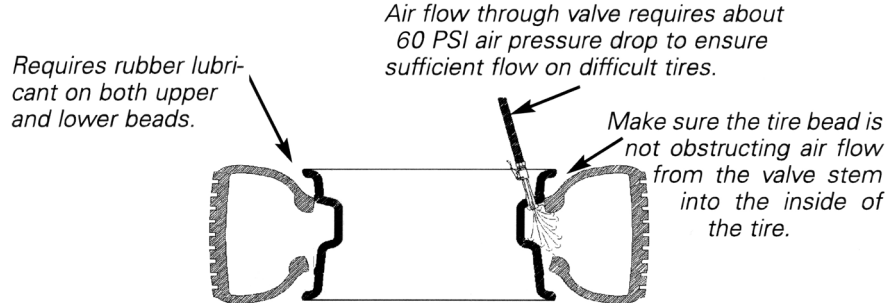

Bead Seating

Bead seating usually occurs on the long tapered side of the wheel first and the shorter side last. Bead seating will usually require at least 7 PSI in the tire. 40 PSI is the maximum safe pressure at this stage regardless of tire operating pressure.

Most European import cars and many aftermarket alloy wheels are very tight and can be difficult to bead seat. Also note that asymmetrical hump and run-flat tires are extremely difficult to bead seat. Follow tire manufacturer's recommended procedure for bead seating.

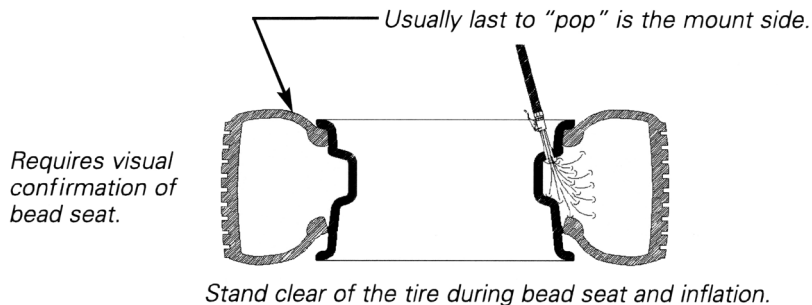

Inflation

After the beads are seated, the tire is ready to be inflated. Do not inflate the tire above the manufacturer's recommended pressure as stamped on the tire sidewall. The typical inflation pressure for automobile tires is between 24 and 45 PSI. Light truck inflation pressure typically covers a wider range.

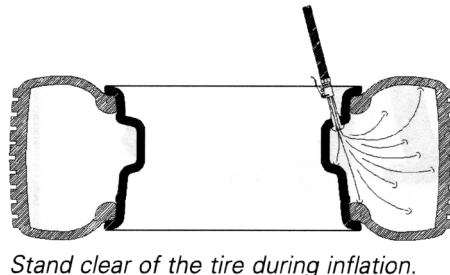

Mismatched Tires and Wheels

Never attempt to mount and inflate mis-matched tires and wheels.

! DANGER

Mismatched tire and wheel combinations can explode, causing personal injury or death to operator and/or bystanders.

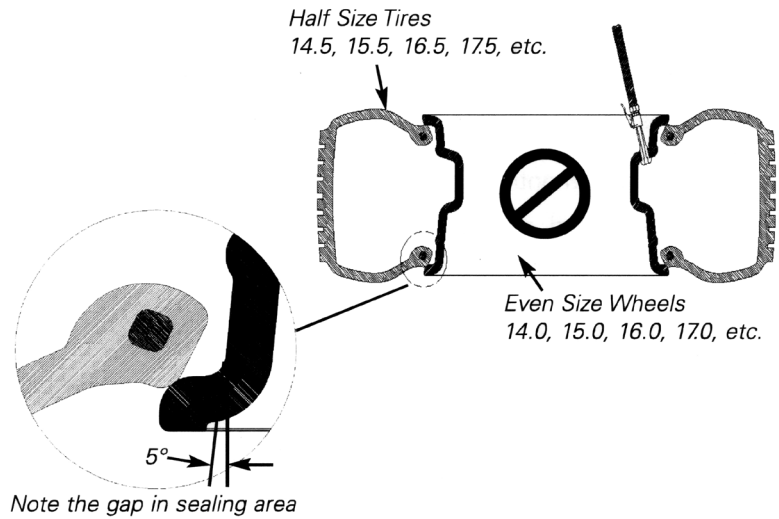
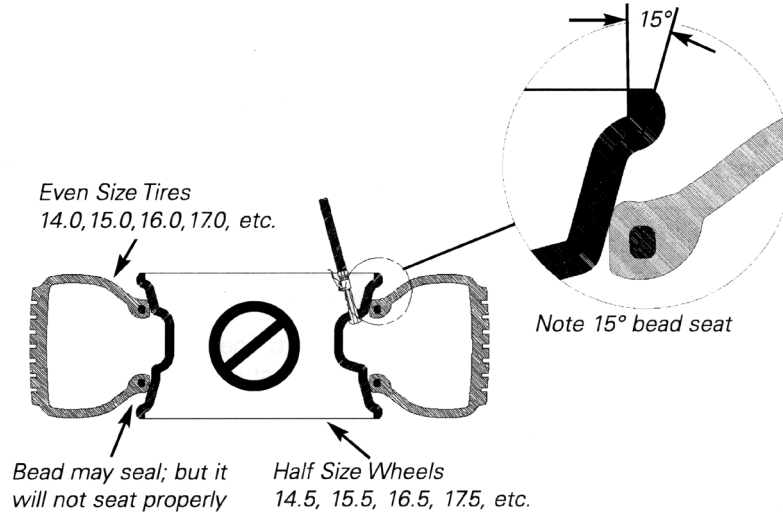

Operating Instructions (using Robo-Assist™ Helper Arm)

Unit must be properly operated and properly maintained to help avoid accidents that could damage the unit and injure the operator or bystanders. These instructions should be reviewed with all employees before they are allowed to work with the machine. Keep these instructions near the machine for easy reference.

Bead Loosening and Demounting (using Robo-Assist™ Helper Arm)

1. Follow procedures described in steps 1 through 9 on pages 8, 9, and 10 - Bead Loosening and Demounting section.

2. Depress the tire sidewall downward with the aid of the Robo-Assist™ helper arm foot providing clearance for the Duckhead® mount/demount tool to be positioned (figure 25). Move swing arm into place. Increase the horizontal distance between the mount/demount tool and the wheel an additional 1/16 to 1/8 inch with the adjustment knob. Remove helper arm.



Figure 25 - Helper Arm Foot Depressing Sidewall of Tire

3. Lubricate upper bead liberally (Figure 26).



Figure 26 - Lubricate Upper Bead

4. Locate the valve stem just before the mount/demount tool before proceeding (Figure 27).

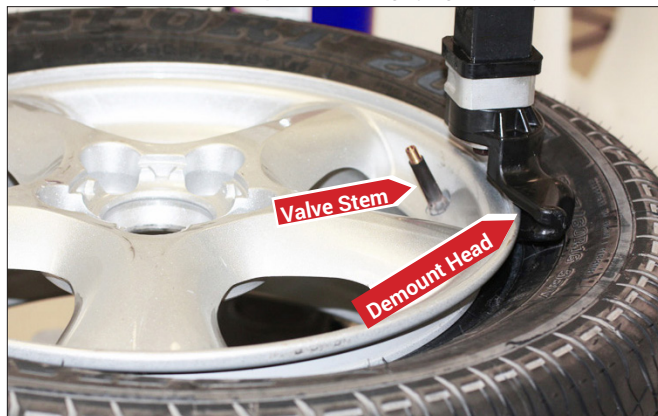

Figure 27 - Position Valve Stem Under Mount/Demount Tool

5. Place the Robo-Assist™ helper arm foot opposite the mount/demount tool and push the bead into drop center. Insert bead lifting tool between knob on mount/demount tool and tire bead (Figure 28).



Figure 28 - Insert Bead Lifting Tool

6. Rotate lifting tool down over wheel to lift bead up and over the knob and at the same time remove helper arm foot.

7. Hold lifting tool in place, depress the table top rotation pedal momentarily to jog the wheel a short distance. Check the wheel and tire to verify that operation is not causing damage. The lifting tool can usually be removed after jogging the wheel a short distance (Figure 29). Continue to jog the wheel to allow the tire sidewall to flex as it crosses the rim edge. Continue short rotations until top bead is completely demounted.



Figure 29 - Holding Lifting Tool in Place and Rotate Wheel

8. Demount lower bead. Pay close attention to sensor/transmitter location, and position it just before the mount/demount tool when starting the lower bead demount procedure (Figure 30).



Figure 30 - Sensor/Transmitter Location

9. Lift and hold the tire at an angle so the lower bead is resting in the drop center directly across from the mount/demount tool, and is loose below the mount/demount tool. Insert bead lifting tool down over mount/demount tool and below the lower bead. Lift the lower bead over the mount/demount tool (Figure 31). Hold the bead lifting tool in place. Depress the table top rotation pedal momentarily to jog the wheel short distances to complete the demounting process.



Figure 31 - Lower Tire Bead in Drop Center

Mounting (using Robo-Assist™ Helper Arm)

1. Lubricate both tire beads liberally. Performance tires will require more lubrication than standard passenger car tires.

2. Mount the lower bead. In most cases, the lower bead will mount easily.

TECH TIP Mounting the top bead can be very difficult when mounting new tires on performance and custom wheels. Proceed slowly and cautiously.

3. Position the valve stem 90 degrees clockwise in front of the mount/demount tool for top bead mounting. Lift the bead over the rear tail of the mount/demount tool. Use the Robo-Assist™ helper arm to hold the bead in the drop center (Figure 32). Rotate the wheel in short steps and apply extra lubricant to mount upper tire bead.



Figure 32 - Mount Upper Tire Bead, Use Helper Arm

4. On extremely tight tire and wheel combinations, it may be necessary to use the bottom of the assist foot to flip the tire bead over the rim flange (Figure 33)



Figure 33 - Helper Arm Foot to Flip Bead Over Rim Flange

Tube Type Tires

Mounting

- 1.** Avoid pinching or forcing the tube.
- 2.** Apply rubber lubricant to the tire beads of the tire.
- 3.** Mount the bottom tire bead.
- 4.** Round out the tube with a small amount of air.
- 5.** Apply rubber lubricant to the tube.
- 6.** Insert the tube into the tire.
- 7.** Mount the top tire bead.

Demounting

- 1.** After tire beads are loosened, lubricate the beads and rim liberally.
- 2.** Position Duckhead® mount/demount tool and bead lifting tool as described in steps 7 through 10 on pages 9 and 10. Depress table top pedal and rotate only a short distance at a time. This allows you to stop the process should the tube get pinched.
- 3.** After upper tire bead is demounted, remove tube and demount lower tire bead.

Maintenance Instructions

Read and follow all the maintenance instructions provided in this manual to keep the machine in good operating condition. Refer to the other materials received with the unit and to the service bulletins from the manufacturer for additional instructions on proper maintenance and service. Regular inspections and proper maintenance are essential to preventing accidents and injuries.



Always **DISCONNECT ELECTRICAL POWER** and block out all moving parts before making any inspection, adjustment, or repair to the machine. This prevents electrical shock or accidental movement of the systems operated by the electrical power.



Always **DISCONNECT AIR SUPPLY** before servicing machine. This prevents accidental movement of systems operated by compressed air which may result in personal injury. **BLEED AIR SYSTEM** by actuating all the valves.



Keep the machine and the immediate work area clean. Do not use compressed air to remove dirt and debris from the machine. Foreign material may be propelled into the air and into operator or bystander causing personal injury.



Wear protective clothing, equipment and eye protection when making any adjustments or repairs to the machine.



Replace any damaged or missing safety decals. They are available from Hennessy Industries, Inc., (800) 688-6359.

Important: These instructions will help you service the unit. Instructions are for a person with some mechanical ability and training. No attempt has been made to describe all basic steps, for example, how to loosen or tighten fasteners. Also basic procedures such as cycling systems and checking operation of the equipment are not fully described since they are known to anyone who does mechanical and service work. Do not attempt to perform work beyond your ability or at which you have no experience. If you need assistance, call an authorized service center.

1. The vertical slide should be cleaned with a vaporizing solvent and then lubricated with chassis grease once a month.

2. Check the adjustment of the Duckhead® mount/demount tool once a month.

3. Check the fluid level in the table top transmission once every 3 months. While wearing rubber gloves, remove the fill port plastic plug and inserting your finger to check the fluid level. If your gloved finger touches the oil, the transmission is properly filled. If your glove remains dry, add a high quality SAE 80/90 gear lubricant. Repeat steps 2 & 3 to recheck the fluid level. Reinstall the fill port plastic plug.

4. The table top, clamps, steel Duckhead® mount/demount tool, and other working surfaces should be cleaned with a vaporizing solvent every month.

5. The clamps should be inspected and metal chips and dirt removed from the serrations with a wire brush every month.

6. Check the tire pressure gauge function daily, and check the accuracy monthly. Use a pressurized tire and a high quality stick-type pressure gauge. If the gauge is defective, replace it immediately (part number 8107985). Check function of the pressure regulator weekly.

7. Make sure all fasteners are securely tightened.

8. Make certain that all guards and covers are in place.

9. Check for worn, damaged or missing parts including grips and protective covers. Replace them before allowing the unit to be used.

10. On a daily basis, inspect the unit and check to be certain that all systems are operating normally. Detailed inspection and testing procedures are specified for various components at regular intervals. Set up a chart and assign responsibility for these items

11. Replace any damaged or missing safety decals. They are available from Hennessy Industries, Inc., (800) 688-6359.

Mount/Demount Tool Cleaning

Clean dirt and debris from the Duckhead® mount/demount tool roller with a small screwdriver or pick.



Figure 34 – Clean Duckhead® Mount/demount Tool Using Small Screwdriver

Mount/Demount Tool Adjustment

To Adjust Lock Tightness

With lock handle unlocked, loosen jam nut (ref. 1) and adjust pin (ref. 2) until a slight firmness is obtained, then tighten jam nut and check. Also recheck tool lift at this time.

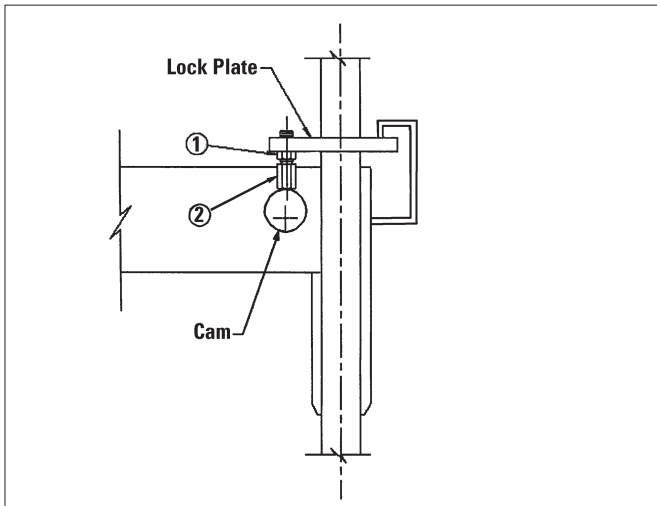

Figure 35 – Mount/Demount Tool Adjustment

Robo-Assist® Helper Arm Maintenance

Grease the Robo-Assist® Helper Arm to maintain smooth rotation. Grease fittings are installed at the pivot joints.

Check bolt torque periodically at pivot joints. Proper Torque is 240 ft. lb.

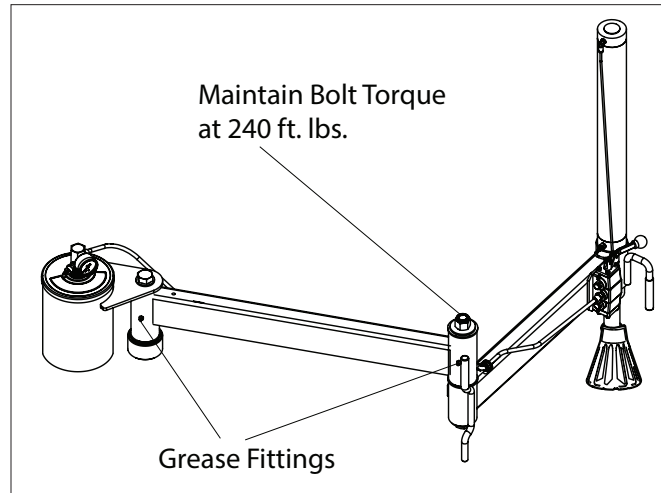

Figure 36 – Grease Robo-Assist® Joints and Torque bolts

Pressure Regulator Maintenance

! DANGER

Operating a tire changer with a defective, improperly adjusted, or by-passed pressure regulator could cause an operator to accidentally over pressurize a tire, resulting in a tire explosion with severe injury or death to the operator or bystanders.

Always be sure that the pressure regulator is present and is operating properly.

! DANGER

Never inflate tire above manufacturer's recommended pressure after bead is seated. Pressure regulator is set at 60 PSI. Any required inflation above 60 PSI should be performed in an inflation chamber/safety cage or securely mounted on the vehicle if an inflation chamber is not available. A tire explosion may cause personal injury or death to operator or bystanders.

The pressure regulator helps prevent inflation of standard size or larger tires or tubes beyond 60 PSI to minimize risk of explosion. This device is for the safety of the operator and bystanders. Proper operation of the pressure regulator is essential to safe operation of the machine.

Check operation of the pressure regulator as shown and described below at least monthly:

1. Remove tires and/or wheels from the machine.
2. Connect the inflation hose to an empty service tank with a pressure gauge (gauge should read 0). Use a certified tank with at least 200 PSI pressure rating.
3. Depress inflation pedal to position 2 to start airflow through the hose and into the tank. Maintain a steady pressure for constant flow.
4. Watch the rising pressure on the tank gauge and the gauge on the machine. The tank gauge should rise steadily while inflation pressure is applied. As tank pressure reaches 60 PSI, the pressure regulator should stop the airflow automatically. When inflation pedal is released to position 1, machine gauge and tank gauge should read 60 PSI \pm 5 PSI.

5. Replace pressure regulator if it fails to shut air supply off at 60 PSI, or if it malfunctions in any other way. Do not operate machine with a faulty pressure regulator.

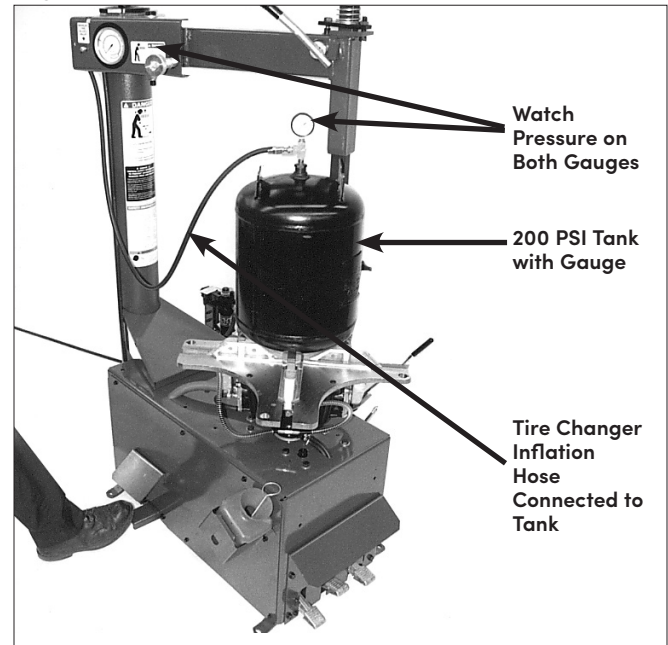

Figure 37 – Pressure Regulator Maintenance

Oil Injector Maintenance

The oil injector typically requires annual service. The oil level in the oil reservoir tank should be checked regularly.

Add oil to oil reservoir tank when fluid level is a quarter full or below. Remove cap from the oil reservoir tank and add Chevron Regal® R & O 32 oil to full line (air tool oil is an acceptable substitute). Replace cap and clean up any spilled oil.

Important: An air lock will form if the hose between the reservoir and injector is ever empty of oil. In this case, after filling the reservoir tank, the line must be bled of air at the injector connection as follows:

1. Disconnect all power sources, both air and electricity inputs. Allow any stored air in the reservoir to escape by depressing the inflate pedal.
2. Remove the side panel and locate the oil injector.
3. Prime the oil injector. Loosen bleeder plug until oil drips from screw and all air is relieved from the oil line hose. Retighten the bleeder screw.
4. Reconnect air/electric sources and cycle the clamp control pedal a few times checking for oil and air leaks.
5. Test the machine for full function before returning the machine to operation.
6. Monitor oil consumption to ensure oil is being used in system.

ONE WORD FOR SAFETY

R.I.M.

READ

INSPECT

MOUNT

READ...

Mounting and inflating the wrong size tire can get you hurt. *Read* the size on the tire and make sure it matches the rim. Be especially careful about putting a smaller tire on a larger rim, such as a 16-inch tire on a 16.5-inch rim.

Inflation of a mismatched tire and rim can cause an explosion.

INSPECT...

Before you put any tire on a rim, *Inspect* the rim for rust, tough spots, bent edges, or cracks that could prevent the tire from seating right. If you spot any of these problems, don't mount the tire until the rim has been checked by your shop foreman.

Inspect the tire for bead damage.

MOUNT...

Once you've made sure the tire is OK and the right size and the rim is OK, *Mount* the tire safely. NEVER, ever lean over the tire when you're inflating it. If a tire does explode, it will go straight up. You don't want to be over the tire if that happens. Also, never over-inflate the tire, even if the bead doesn't seat. Never inflate over 40 PSI. If the tire hasn't seated, something is wrong. Deflate the tire and check it and the rim again. If it doesn't work the second time, try another tire.

BE CAREFUL OF THESE SITUATIONS:

- | | | | |
|---|--|--|--|
| 1. Damaged Bead or Beads. | 4 A. Mismatched. (A mis-match of a 16-inch tire to a 16.5-inch rim causing an explosion) | 5. Walk-In Tire and Rim. | 8. Standing Clear. (Never put any part of your body over the tire changer during inflation.) |
| 2. Rusty Wheels. (particularly in the bead seat area) | 4 B. Mismatched. (16.5-inch tire on a 16-inch rim) | 6. Back Injuries. | 9. Beads will not Seat at 40 PSI. |
| 3. Bent or Cracked Wheels. | | 7. Hand or Finger Injuries. (Hands or fingers too close to inflating tire or bead seats which may cause injury.) | 10. Improper Inflation. |

Remember R.I.M. (Read, Inspect, Mount) for every tire.



FAILURE TO READ AND FOLLOW ALL WARNINGS AND INSTRUCTIONS IN THIS MANUAL CAN LEAD TO SERIOUS PERSONAL INJURY OR DEATH TO OPERATOR OR BYSTANDER.

THE OWNER IS RESPONSIBLE FOR MAINTAINING THE OPERATION INSTRUCTIONS AND DECALS FOR OPERATOR REFERENCE. FOR ADDITIONAL COPIES, CONTACT HENNESSY INDUSTRIES, INC., 1601 J.P. HENNESSY DRIVE, LAVERGNE, TENNESSEE, 37086, (800) 688-6359.

TIRE FAILURE UNDER PRESSURE IS HAZARDOUS! This tire changer Will Not Restrain Exploding Tires, rims or other related equipment.

TIRES CAN EXPLODE, ESPECIALLY IF INFLATED BEYOND SPECIFIED LIMITS. DO NOT EXCEED TIRE MANUFACTURERS RECOMMENDED AIR PRESSURE.

AN EXPLODING TIRE, RIM, OR BEAD SEATING EQUIPMENT MAY PROPEL UPWARD AND OUTWARD WITH SUFFICIENT ENERGY TO CAUSE SERIOUS INJURY OR DEATH TO OPERATOR AND/OR BYSTANDERS.