

SPINDLE DRIVE ASSEMBLY

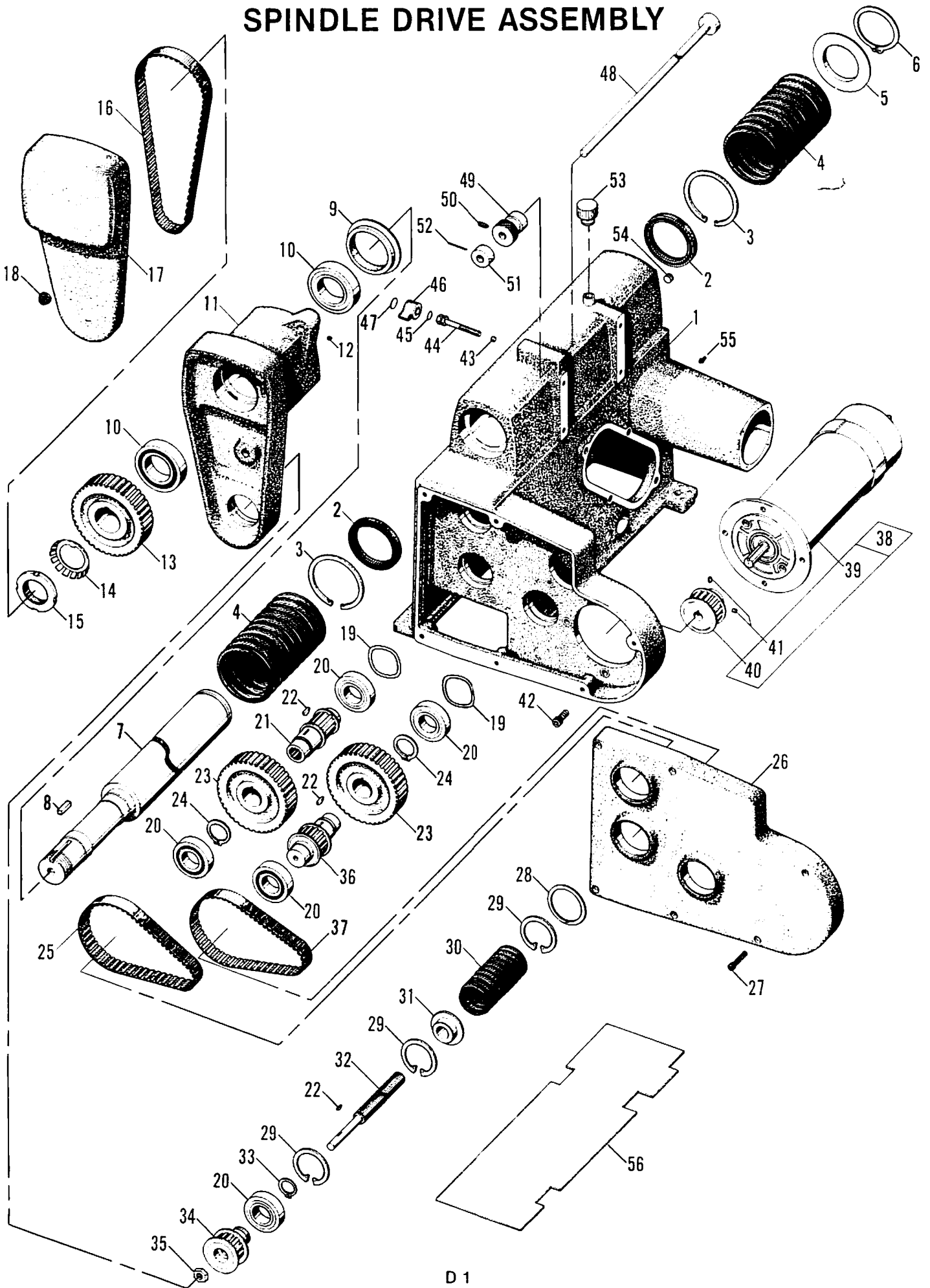

SPINDLE DRIVE ASSEMBLY

ITEM	PART NO.	QTY.	DESCRIPTION	ITEM	PART NO.	QTY.	DESCRIPTION
1	22801	1	Main Frame Assembly	31	23817	3	Support, Boot
2	3164	2	Seal	32	22994	1	Shaft, Drive
3	23939	2	Ring, Retaining, Spindle Boot	33	23537	1	Ring, Retaining
4	22998	2	Boot	34	22996	1	Pulley, Drive
5	23682	1	Ring, Boot Mounting	35	31799	1	Nut
6	3159	1	Ring, Retaining	36	23874	1	Shaft, Jack
7	22991	1	Spindle	37	23550	1	Belt
8	23931	1	Key	38	26883	1	Motor Assembly, 117 V
9	23936	1	Ring, Retainer Boot		26666	1	Motor Assembly, 235 V
10	23541	2	Bearing	39	26881	1	Motor, Spindle Drive, 117 V, 60 Hz - 90 VDC
11	22987	1	Yoke		22816	1	Motor, Spindle Drive, 235 V, 50 Hz
12	212	1	Screw, Set	40	23559	1	Pulley
13	22995	1	Pulley	41	2308	2	Screw, Set
14	6981	1	Washer, Lock	42	3860	4	Screw
15	6980	1	Nut, Lock	43	9836	1	Plug, Brass
16	22997	1	Belt	44	23786	1	Screw, Lock
17	22989	1	Cover, Yoke	45	23705	1	Ring, "O"
18	23546	1	Nut	46	23017	1	Knob
19	23830	4	Washer, Wave	47	23584	1	Cover
20	23543	5	Bearing	48	23703	1	Rod, Shut-Off
21	23630	1	Tube Driver	49	23020	1	Stop, Adjustable
22	3176	3	Key	50	21844	1	Spring, Plunger
23	23002	2	Pulley	51	23018	1	Collar, Shut-Off
24	23540	2	Ring, Retaining	52	6204	1	Pin, Roll
25	23551	1	Belt	53	23737	1	Dipstick, Oil
26	22988	1	Cover, Rear	54	3372	1	Plug, Oil Drain
27	3319	6	Screw	55	22006	1	Fitting, Grease
28	23829	2	Ring, Retaining	56	24040	1	Cover, Bottom
29	23938	3	Ring, Retaining Boot				
30	23006	1	Boot				

big # 2017 2015 L100

Get bolts from drums (bearing shaft)

SPINDLE FEED ASSEMBLY

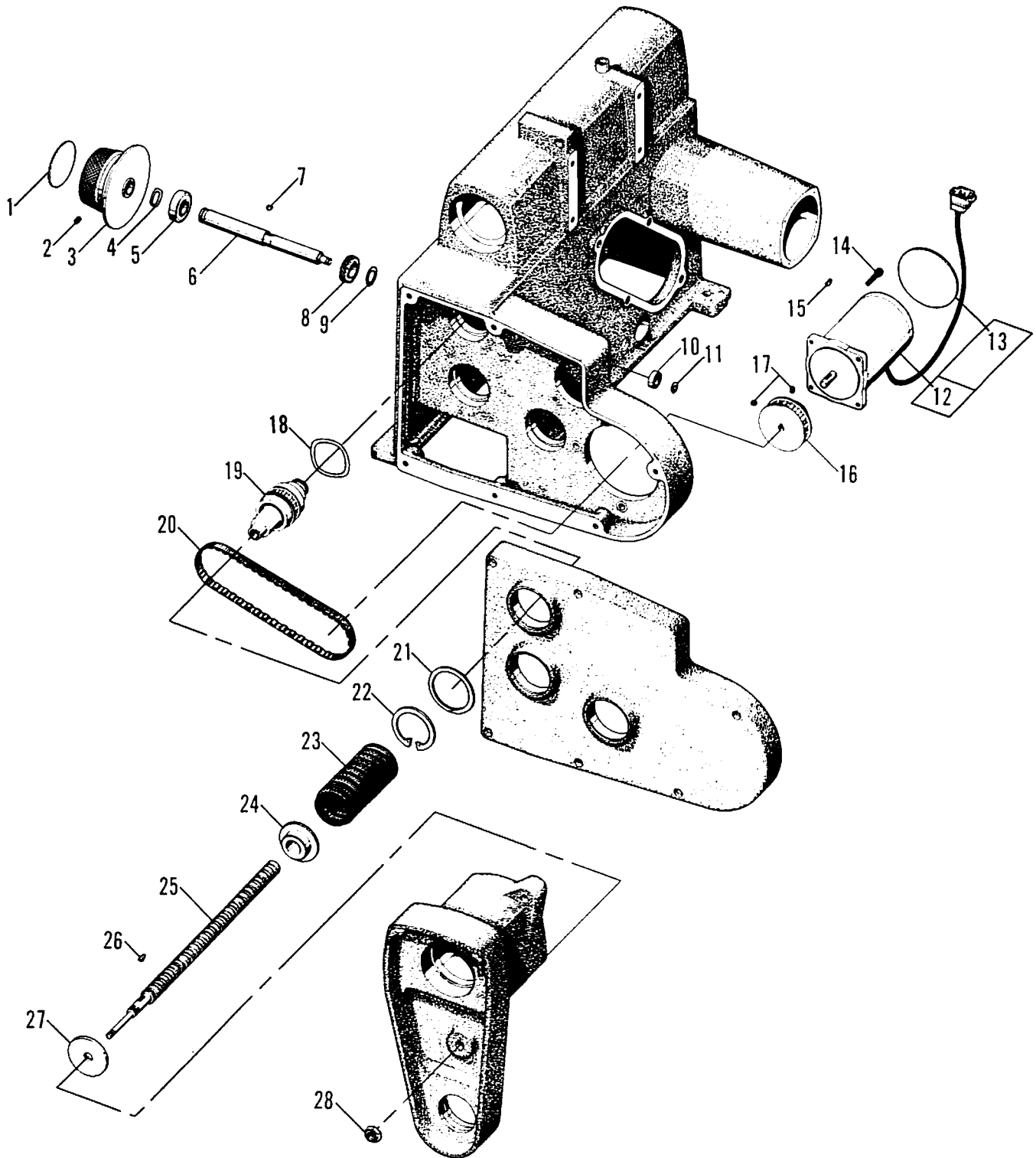

SPINDLE FEED ASSEMBLY

ITEM	PART NO.	QTY.	DESCRIPTION
1	23032	1	Cover, Knob
2	23790	1	Knob, Spindle Feed
3	2308	1	Screw, Set
4	21082	1	Washer, Wave
5	23542	1	Bearing
6	23788	1	Shaft, Handwheel. Spindle Feed
7	6972	1	Key
8	23691	1	Gear, Handwheel
9	23688	1	Ring, Retaining
10	23547	1	Bearing
11	5613	1	Ring, Retaining
12	23690	1	Feed Motor Assembly
13	23634	1	Nameplate
14	6254	4	Screw
15	23548	1	Key
16	23558	1	Pulley
17	23858	2	Screw, Set
18	23830	1	Washer, Wave
19	23035	1	Feed Gear Assembly
20	23552	1	Belt
21	23829	1	Ring, Retaining
22	23938	1	Ring, Retaining Boot
23	23006	1	Boot
24	23817	3	Support, Boot
25	22993	1	Screw, Lead. Spindle Feed
26	3176	1	Key
27	23937	1	Disc. Boot Retaining
28	31799	1	Nut

NOTE: A pulley puller must be used when removing any pulley.

CROSS FEED DRIVE ASSEMBLY

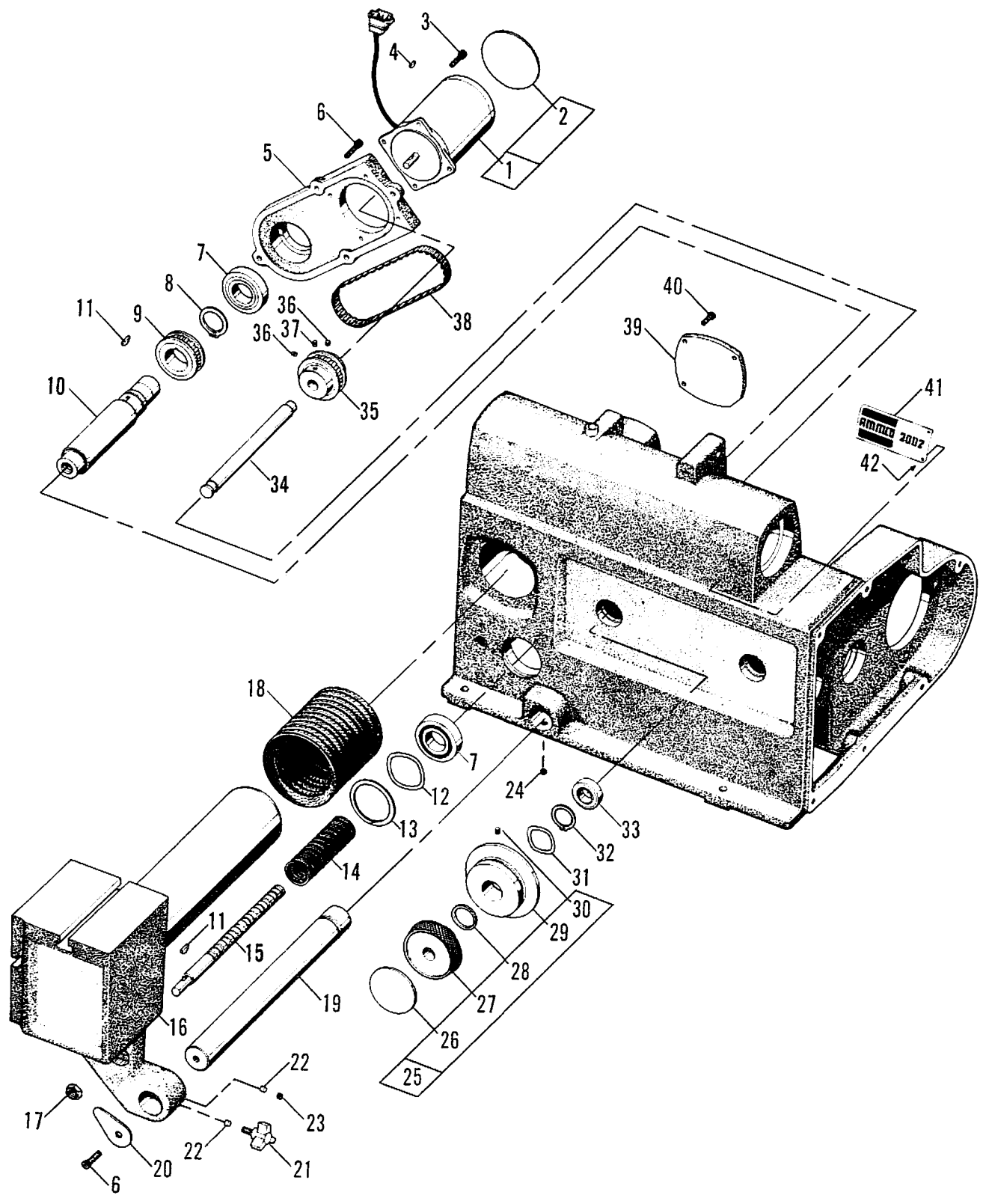

CROSS FEED DRIVE ASSEMBLY

ITEM	PART NO.	QTY.	DESCRIPTION
1	23690	1	Motor
2	23634	1	Nameplate
3	6254	4	Screw
4	23548	1	Key
5	22990	1	Plate, Drive
6	209	5	Screw
7	23543	2	Bearing
8	23540	1	Ring, Retaining
9	23005	1	Pulley
10	23003	1	Sleeve, Screw
11	3176	2	Key
12	23830	*	Washer, Wave
13	23829	1	Ring, Retaining
14	23567	1	Boot
15	23004	1	Screw, Lead
16	23697	1	Post, Tool
17	24038	1	Nut
18	3087	1	Boot, Cross Feed
19	23789	1	Rod, Guide
20	23739	1	Out-stop
21	6854	1	Knob, Lock
22	3142	2	Plug, Brass
23	25246	1	Screw, Cone Point Set
24	220	2	Screw, Set
25	23696	1	Handwheel Assembly
26	23032	1	Cover, Knob
27	23015	1	Knob, Handwheel
28	23582	1	Washer, Nylon
29	23791	1	Ring, Indicator
30	23858	1	Screw, Set
31	23544	1	Washer, Wave
32	23539	1	Ring, Retaining
33	23542	1	Bearing
34	23010	1	Shaft, Handwheel
35	23787	1	Pulley
36	1888	2	Screw, Set
37	25441	1	Screw
38	23552	1	Belt
39	23694	1	Cover, Cross Feed
40	6801	3	Screw
41	23876	1	Nameplate
42	306	4	Screw, Drive

* As Required

CONTROL PANEL ASSEMBLY

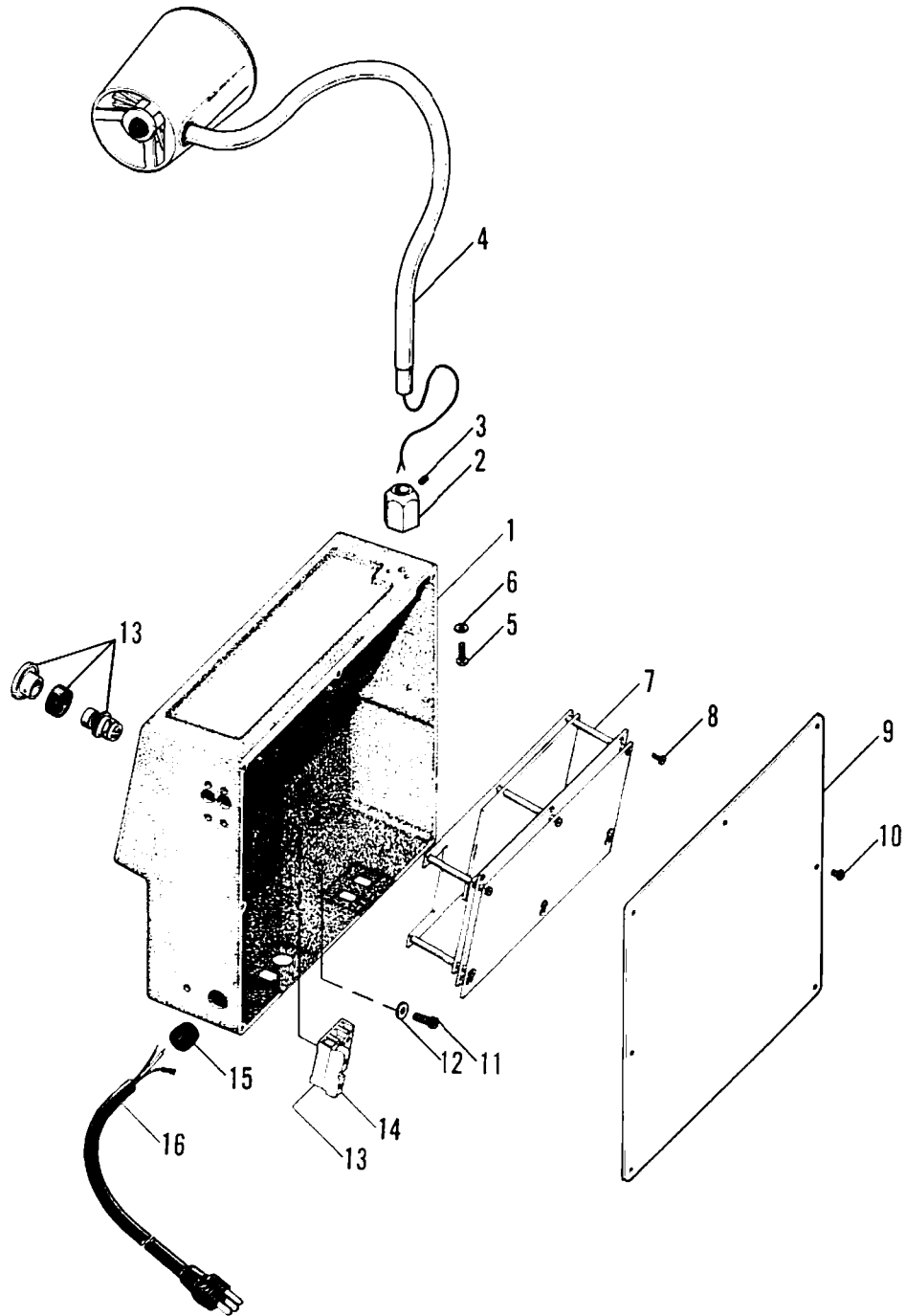

CONTROL PANEL ASSEMBLY

ITEM	PART NO.	QTY.	DESCRIPTION
1	23026	1	Box, Control Panel
2	26821	1	Block, Lite
3	3338	1	Screw, Set
4	26731	1	Lamp Assembly
5	2799	2	Screw
6	4379	2	Washer
7	26728	1	Printed Circuit Board Assembly, 120 VAC, 60 Hz
		1	Printed Circuit Board Assembly, 240 VAC, 50 Hz**
8	24759	6	Screw
9	26874	1	Panel, Back Assembly
10	6353	7	Screw, Button Head Hex
11	209	4	Screw
12	1574	4	Washer
13	22792	1	Switch, Safety
14	25159	1	Contact Block, Switch
15	6058	1	Grip, Cord 120 V, 60 Hz
	6077	1	Grip, Cord 240 V, 50 Hz
16	23575	1	Cord Set, 120 V, 60 Hz
	7210	1	Cord Set, 240 V, 50 Hz
	24237	*	Tape, Foam (Not Shown)

* As Required

** Consult Manufacturer for Part Number

CONTROL PANEL ASSEMBLY

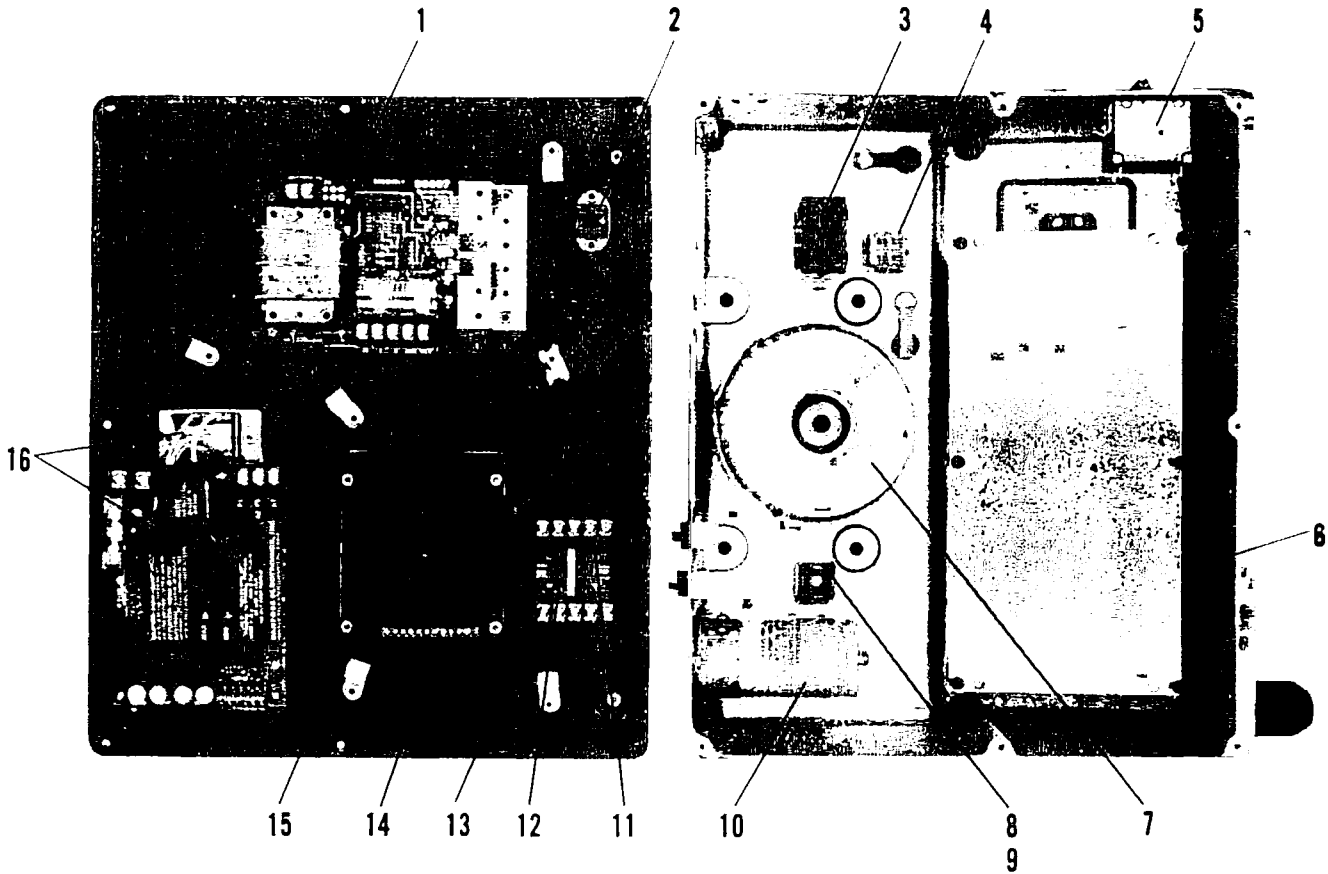

WIRING DIAGRAM

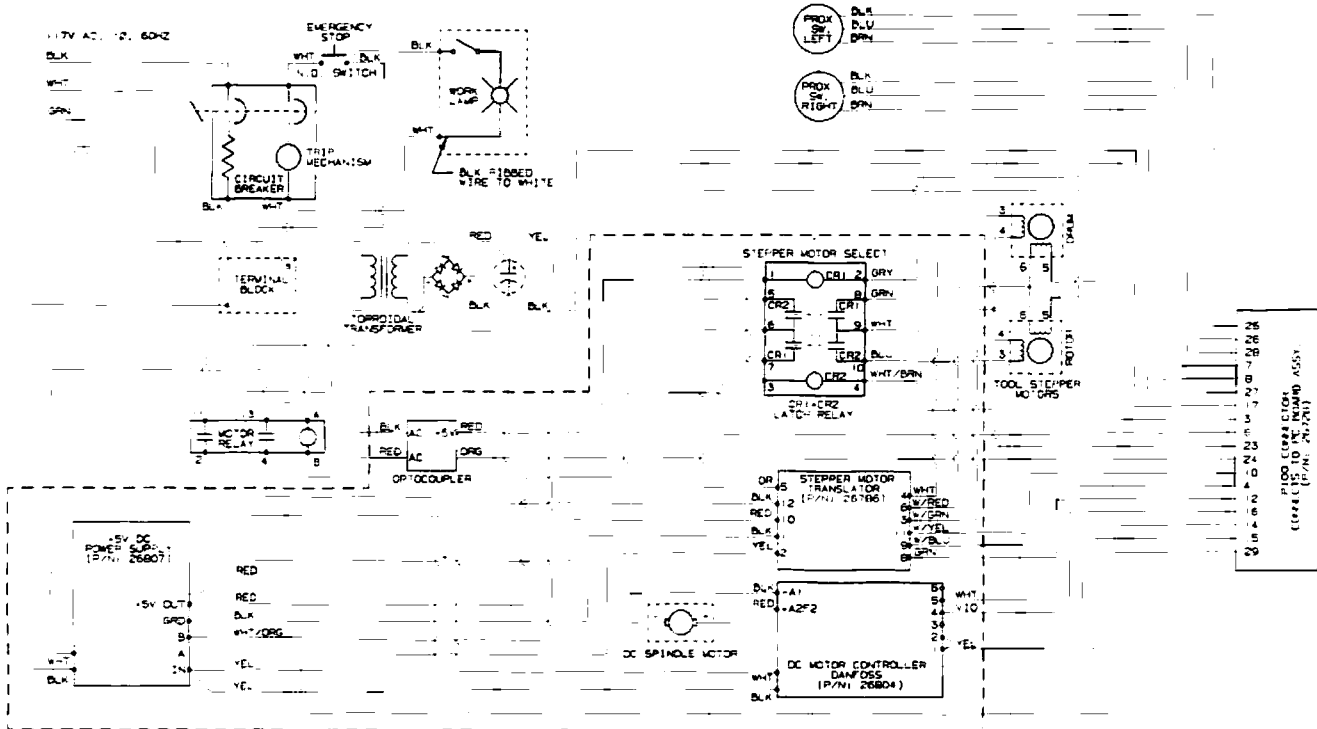

BACK PANEL MOUNTED COMPONENTS

CONTROL PANEL ASSEMBLY

ITEM	PART NO.	QTY.	DESCRIPTION
1	26807	1	Supply, Power
2	26805	1	Relay
3	22795	1	Relay
4	26826	1	Harness, Wiring, AC Power*
5	22788	1	Breaker, Circuit
6	26784	1	Harness, Wiring, Control*
7	25362	1	Transformer
8	22782	1	Bridge, Diode
9	26820	1	Harness, Wiring, DC Power*
10	25206	1	Capacitor
11	26802	1	Socket, Relay
12	26803	1	Relay, Feed Motor
13	26801	1	Harness, Control Interface*
14	26753	1	Harness, Feed Motor*
15	26786	1	Controler, Feed Motor
16	26804	1	Controler, Spindle Motor

* Not Shown for Clarity

TOOLING

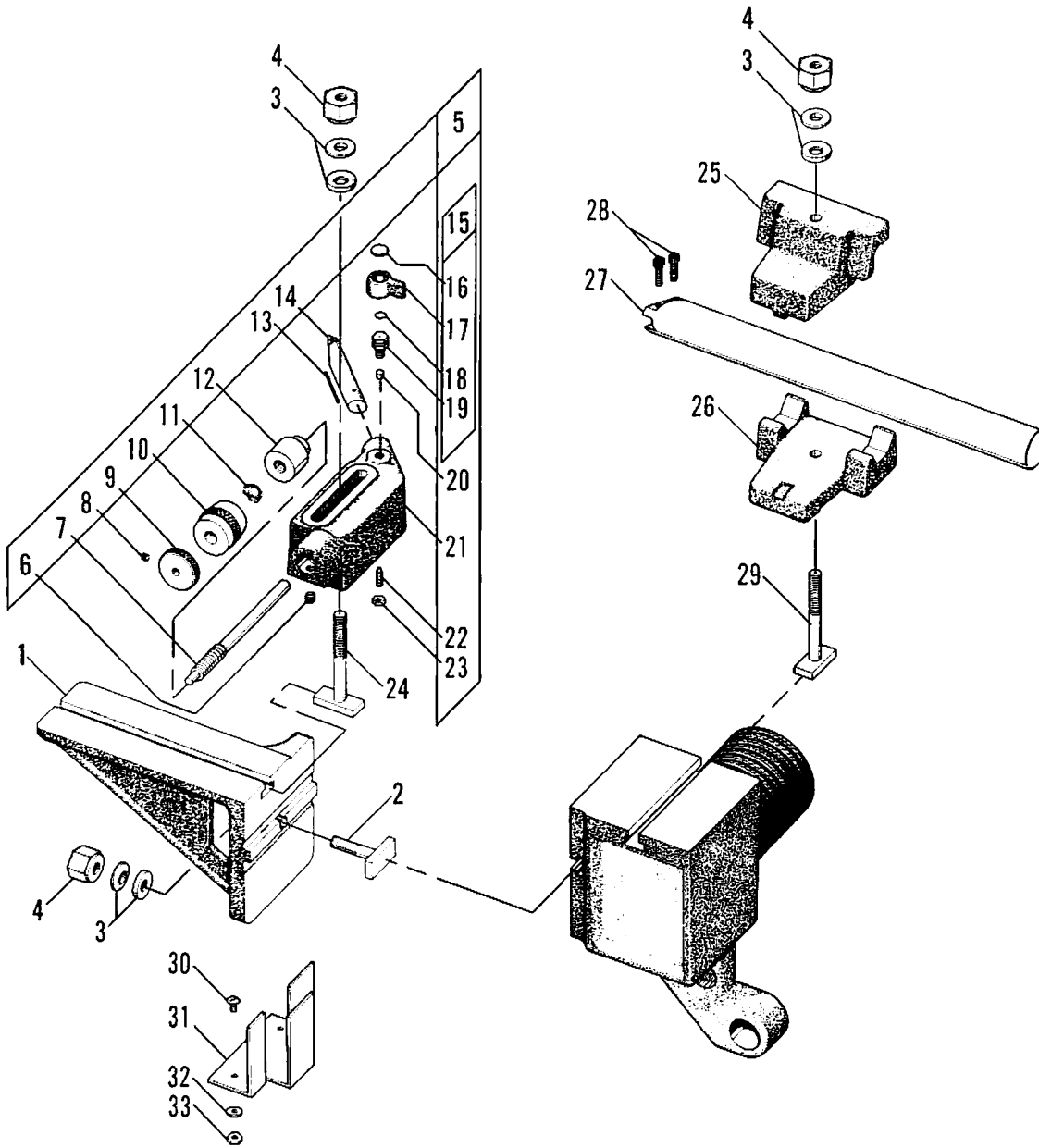

TOOLING

ITEM	PART NO.	QTY.	DESCRIPTION
1	23007	1	Post, Facing Tool
2	23760	1	T-Bolt
3	3165	4	Washer, Spherical Set
4	23753	4	Nut, T-Bolt
5	23711	1	Twin Cutter Assembly. R.H.
	23712	1	Twin Cutter Assembly. L.H.
6	2993	2	Screw, Set
7	23023	2	Rod, Dial
8	3338	2	Screw, Set
9	6923	2	Knob, Dial Rod
10	6907	2	Dial, Micrometer
11	6929	2	Washer, Spring
12	6906	2	Plug, Dial
13	23707	2	Spring
14	23709	1	Holder, Tool R.H.
	23714	1	Holder, Tool L.H.
15	23706	2	Lock Knob Assembly
16	23584	2	Cover
17	23017	2	Knob
18	23705	2	Ring, "O"
19	23695	2	Stud, Lock
20	3142	2	Plug, Brass
21	23021	1	Body, Cutter R.H.
	23792	1	Body, Cutter L.H.
22	9879	2	Screw, Locating
23	3528	2	Nut, Jam
24	23772	2	T-Bolt
25	23525	1	Clamp, Top
26	23500	1	Clamp, Base
27	23555	1	Bar, Boring
28	5689	2	Screw, Set
29	23556	1	T-Bolt
30	24100	2	Screw
31	23785	1	Bracket, Twin Cutter Storage
32	4379	2	Washer
33	251	2	Nut