

**COATS  
BADA**

**AMMCO**

# 1350 & 1450

## AMMCO Brake Washer Systems



### Installation and Operating Instructions

*With Safety and Maintenance  
Instructions and Parts Identification*

READ these instructions before placing unit in service. KEEP these and other materials delivered with the unit in a binder near the machine for ease of reference by supervisors and operators.

Manual Part No.: 629708  
Revision Date: 02/07  
rev. 08

**HENNESSY INDUSTRIES, INC.**

1601 J. P. Hennessy Drive, LaVergne, TN USA 37086 615/641-7533 800/688-6359

HENNESSY INDUSTRIES INC. Manufacturer of AMMCO®, COATS® and BADA® Automotive Service Equipment and Tools.



These instructions are for the AMMCO Model 1350 Portable Brake Washer and the AMMCO Model 1450 Deluxe Brake Washer. Refer to the parts list for identification.

## Table of Contents

### Before You Begin

Receiving .....1

### Assembly

Tool List .....1

Assembly, 1450 .....2

Assembly, 1350 .....2

### Operation

General Instructions .....3

Disc Brakes .....3

Drum Brakes .....3

Maintenance .....4 & 5

Parts Illustration .....5 - 9

Warranty .....10

## Tools required for Assembly

$\frac{3}{8}$ " ,  $\frac{7}{16}$ " ,  $\frac{1}{2}$ " , &  $\frac{9}{16}$ " Wrenches  
Straight Blade Screwdriver

## Receiving

The shipment should be thoroughly inspected as soon as it is received. The signed bill of lading is acknowledgement, by the carrier, of receipt in good condition of the shipment covered by our invoice.

If any of the goods called for on this bill of lading are shorted or damaged, do not accept them until the carrier makes a notation of the shorted or damaged goods on the freight bill. Do this for your own protection.

NOTIFY THE CARRIER AT ONCE if any hidden loss or damage is discovered after receipt and request him to make an inspection. If the carrier will not do so, prepare an affidavit to the effect that you have so notified the carrier (on a certain date) and that he failed to comply with your request.

IT IS DIFFICULT TO COLLECT FOR LOSS OR DAMAGE AFTER YOU HAVE GIVEN THE CARRIER A CLEAR RECEIPT.

File your claim with the carrier promptly. Support your claim with copies of the bill of lading, freight bill, invoice, and photographs, if possible.

Although AMMCO's responsibility ceases upon delivery of shipment to the carrier, we will gladly assist in tracing lost shipments. Our willingness to assist in every possible manner does not make AMMCO responsible for collection of claims or replacement of lost or damaged materials.

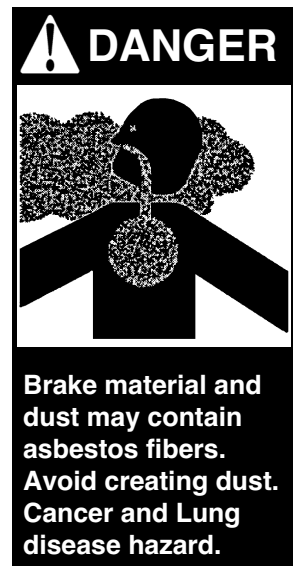

## ASSEMBLY MODEL 1450 DELUXE BRAKE WASHER

1. Turn base and barrel assembly upside down.
2. Align caster bracket holes with holes in base.
3. Use the  $\frac{5}{16}$ " screws and nuts to attach casters to base.
4. Turn base and barrel assembly right side up.
5. Attach water filter bracket to outside of barrel using  $\frac{1}{4}$ " screws, washers, and nuts. Make sure washers are on the inside of the barrel.
6. Insert pick-up hose through hole in the side of the barrel and screw strainer onto fitting.
7. Lay the oil boom in the bottom of the barrel.
8. Position the pan and lid assembly on top of the barrel so that the pump will be above the water filter.
9. Expand the locking ring to allow the lid to seat to the top of the barrel. Then tighten ring with the cam lever.
10. Fasten the pump and air filter/regulator to the pan with the #10 screws, washers, and nuts. Make sure the washers are on the inside of the pan.
11. Connect water filter outlet hose to pump "IN" port. Slide lever to lock in place.
12. Unscrew water filter canister and insert filter cartridge. Hand tighten canister.
13. Fill tank to 10 gallon on barrel with water only.
14. Pour one quart of AMMCO cleaner into the barrel.

**NOTE: DO NOT USE GASOLINE OR FLAMMABLE SOLVENTS IN THIS BRAKE WASHER. USE ONLY ORIGINAL AMMCO PRODUCTS FOR YOUR SAFETY AND TO ENSURE COMPLIANCE TO O.S.H.A. REGULATIONS.**

15. Insert filter sock into pan drain hole and place drain grate on top of sock.
16. Add quick connector fitting to washer air inlet hose.
17. Connect "Y" hose assembly to pump "OUT" port. Slide lever to lock in place.

18. Insert (2) long hose ends of "Y" assembly through holes in side of pan assembly.
19. Screw gun assemblies on the ends of "Y" hose assembly.
20. Place parts basket over side of pan.
21. Write date on service sticker and apply to a convenient location on washer.

## ASSEMBLY MODEL 1350 PORTABLE BRAKE WASHER

1. Fasten the pump and air filter/regulator to the pan with the #10 screws, washers, and nuts. Make sure the washers are on the inside of the pan.
2. Screw pick-up hose/strainer assembly into bulk-head fitting on the inside of pan.
3. Screw hose assembly into outside of bulk-head fitting. Connect other end to pump "IN" port. Slide lever to lock in place.
4. Place filter filler in center depression of pan.
5. Lay filter mat in bottom of pan, smooth side up.
6. Pour 3 gallons of **water only** into pan.
7. Pour 1/3 bottle of AMMCO cleaner in pan.

**NOTE: DO NOT USE GASOLINE OR FLAMMABLE SOLVENTS IN THIS BRAKE WASHER. USE ONLY ORIGINAL AMMCO PRODUCTS FOR YOUR SAFETY AND TO ENSURE COMPLIANCE TO O.S.H.A. REGULATIONS.**

8. Add quick connector fitting to washer air inlet hose.
9. Connect "Y" hose assembly to pump "OUT" port. Slide lever to lock in place.
10. Insert (2) long hose ends of "Y" assembly through holes in side of part assembly.
11. Screw gun assembly on the ends of "Y" hose assembly.

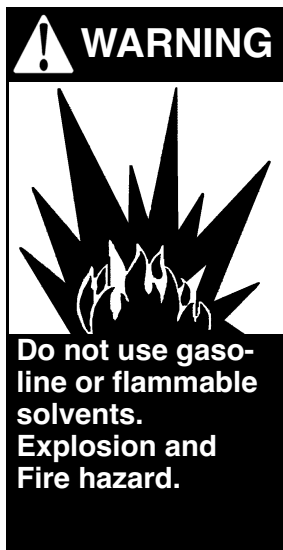

12. Place parts basket over side of pan.
13. Write date on service sticker and apply to a convenient location on washer.

## OPERATION

**NOTE: DO NOT ADD AIR TOOL OIL OR OTHER OILS TO AIR INLET OF WASHER. UNIT IS EQUIPPED WITH A COALESCING FILTER TO CLEAN AIR SUPPLY OF ANY OIL. OILS COULD DAMAGE THE AIR PUMP AND WILL VOID THE WARRANTY.**

1. Connect shop air to washer. The air regulator on the washer is pre-set and cannot be adjusted. The maximum air pressure that can be supplied to the washer is 200 psi.
2. The pump will automatically function when the valve lever is depressed on either the brush or the flex spout.

**NOTE: IT WILL TAKE A FEW SECONDS TO PRIME THE FLUID SYSTEM THE FIRST TIME IT IS USED. AFTER THE INITIAL PRIMING, DO NOT LET THE PUMP RUN DRY. DAMAGE TO THE PUMP COULD OCCUR WHICH WILL VOID THE WARRANTY.**

3. Store cover on pan when the washer is not in use to help prevent evaporation of cleaning solution. This also prevents any asbestos in the dried solutions from blowing around the shop.
4. The cover can be used as a catch basin when doing brake work on the floor or on a service/alignment rack. Thoroughly rinse cover into pan after using.

## DISC BRAKES

1. Simply saturate the entire brake assembly using the flex spout prior to working on brakes.

**NOTE: NEVER USE THE BRUSH TO CLEAN BRAKE FRICTION MATERIAL THAT WILL NOT BE REPLACED NOR DRUMS OR ROTORS THAT WON'T BE TURNED. ANY OIL OR GREASE THAT MIGHT BE ON THE BRUSH COULD BE TRANSFERRED TO THESE BRAKE COMPONENTS.**

## DRUM BRAKES

1. Before loosening or removing drum, use the flex spout to wet the inside of the drum and brake assembly; first, between the drum and backing plate. Then, if the vehicle had adjustment slots; remove the plug and insert the flex spout to wet the inside.
2. If you are doing an inspection, wet the inside of the drum everywhere except the area between the 10 o'clock and the 2 o'clock to make it easier to determine if the wheel cylinder is leaking.
3. Pull the drum off approximately one-inch and wet the brake assembly again.
4. Remove drum and rinse in pan of washer.
5. Check for wheel cylinder leakage and finish washing the assembly.
6. If after inspection the brakes do not need servicing, allow them to air dry before reinstalling the drum.

**NOTE: NEVER USE THE BRUSH TO CLEAN BRAKE FRICTION MATERIAL THAT WILL NOT BE REPLACED NOR DRUMS OR ROTORS THAT WON'T BE TURNED. ANY OIL OR GREASE THAT MIGHT BE ON THE BRUSH COULD BE TRANSFERRED TO THESE BRAKE COMPONENTS.**

7. When doing a complete brake job, thoroughly clean off shoes, drums, and backing plate.
8. Place small brake components in parts basket for convenient cleaning and reassembly.

## MAINTENANCE

**NOTE: USE ONLY ORIGINAL AMMCO PRODUCTS FOR YOU SAFETY AND TO ENSURE COMPLIANCE TO O.S.H.A REGULATIONS.**

### **DISPOSAL OF FILTERS AND CLEANING SOLUTION**

**The AMMCO 1350 and 1450 Brake Washers have been designed to comply with federal, state, and local regulations concerning the disposal of liquid and solid wastes. However, these regulations do vary from place-to-place and it is the shop owner/manager's responsibility to comply with all applicable regulations.**

### **FILTER STOCK (MODEL 1450)**

If the filter sock becomes full, there will be standing water in the pan. Remove drain grate, pull up on filter sock, and discard sock in accordance with you local waste disposal regulations in plastic bag provided. Replace with new sock. The Filter Sock is included with the Model 1350 - see CLEANING SOLUTION Section for intended usage.

### **FILTER MAT (MODEL 1350)**

Solid wasted collected on the filter mat should be placed in a plastic bag and disposed of in accordance with your local regulations. The entire filter mat should be replaced when it becomes worn or damaged. Dispose of filter mat in a plastic bag in accordance with your local regulations.

### **SOLUTION CARTRIDGE FILTER (Model 1450 only)**

When solution does not flow in a continuous stream, replace the cartridge filter on the side of the barrel. Unscrew filter canister, remove and discard dirty cartridge filter in accordance with your local waste disposal regulations in plastic bag provided. Replace with a new cartridge and hand-tighten canister.

### **CLEANING SOLUTION**

Every four months, or more often as required, the cleaning solution should be replaced to allow the washer to continue its cleaning efficiency. Tape or clamp valve levers open so the cleaning solution can be pumped down a sanitary sewer in accordance with your local waste disposal regulations. **For the Model 1350, place guns in Filter Sock before pumping solution into sewer.**

**NOTE: NEVER DISPOSE OF CLEANING SOLUTION INTO A STORM SEWER.**

When most of the solution has been pumped out and the fluid is not a solid stream, add one or two gallons of water to the washer pan. Disconnect air supply to the washer when the clean rinse water is almost gone.

**NOTE: DO NOT LET PUMP RUN DRY. DAMAGE TO PUMP WILL OCCUR THAT WILL VOID WARRANTY.**

Un-tape valve levers, fill barrel to the "FILL LINE" with water, and add one quart of AMMCO cleaner. (Model 1450). Add 1/3 quart of AMMCO cleaner to 3 gallons of water for Model 1350.

**NOTE: WEAR EYE PROTECTION AND RUBBER GLOVES WHEN HANDLING THE CONCENTRATED CLEANER.**

When replacing the cleaning solution, it is a good practice to replace all filters at the same time.

It is a good practice to establish a regular routine for replacing all filters and cleaning solution, such as every month or two months. The interval for your unit will depend on local conditions, types of vehicles serviced, and your volume of brake work. Also, the interval for changing the solution may be different than that for the filters.

continue on next page...

## MAINTENANCE

continued from previous page...

### **CLEANING BRUSH**

When brush gets dirty from brake fluid, axle grease, etc.; clean brush with a degreaser or solvent. **Clean brush in solvent tank, NOT in brake washer.** To prolong brush life and to decrease maintenance, use a shop rag for removal of heavy grease deposits.

### **OIL BOOM**

The oil boom absorbs oil and lubricants but not water. Wring out boom into waste oil tank monthly. The boom can be re-used until it will not float. Dispose of oil boom in accordance with your local waste disposal regulations.

### **AIR FILTERS**

Check and drain both air filter sediment bowls on a regular basis. They can be drained by simply pushing up on the valve located at the bottom of the bowls. The cleanliness of your shop air will determine how often the filters on the washer will need draining. Replace filter elements when air-flow is diminished.

### **Parts Identification**

The following pages include full parts breakdowns with exploded view illustrations to help with ordering re-placement or spare parts. Assemblies are noted where it is recommended that individual parts not be ordered separately. These parts are available only as assemblies because some parts are staked, pinned, or press fitted, then drilled, machined, or bored. Close tolerance must be maintained in assembly. Every effort is made to supply accurate exploded views, however, due to interim changes in manufacturing operations, some units may not be exactly as illustrated.

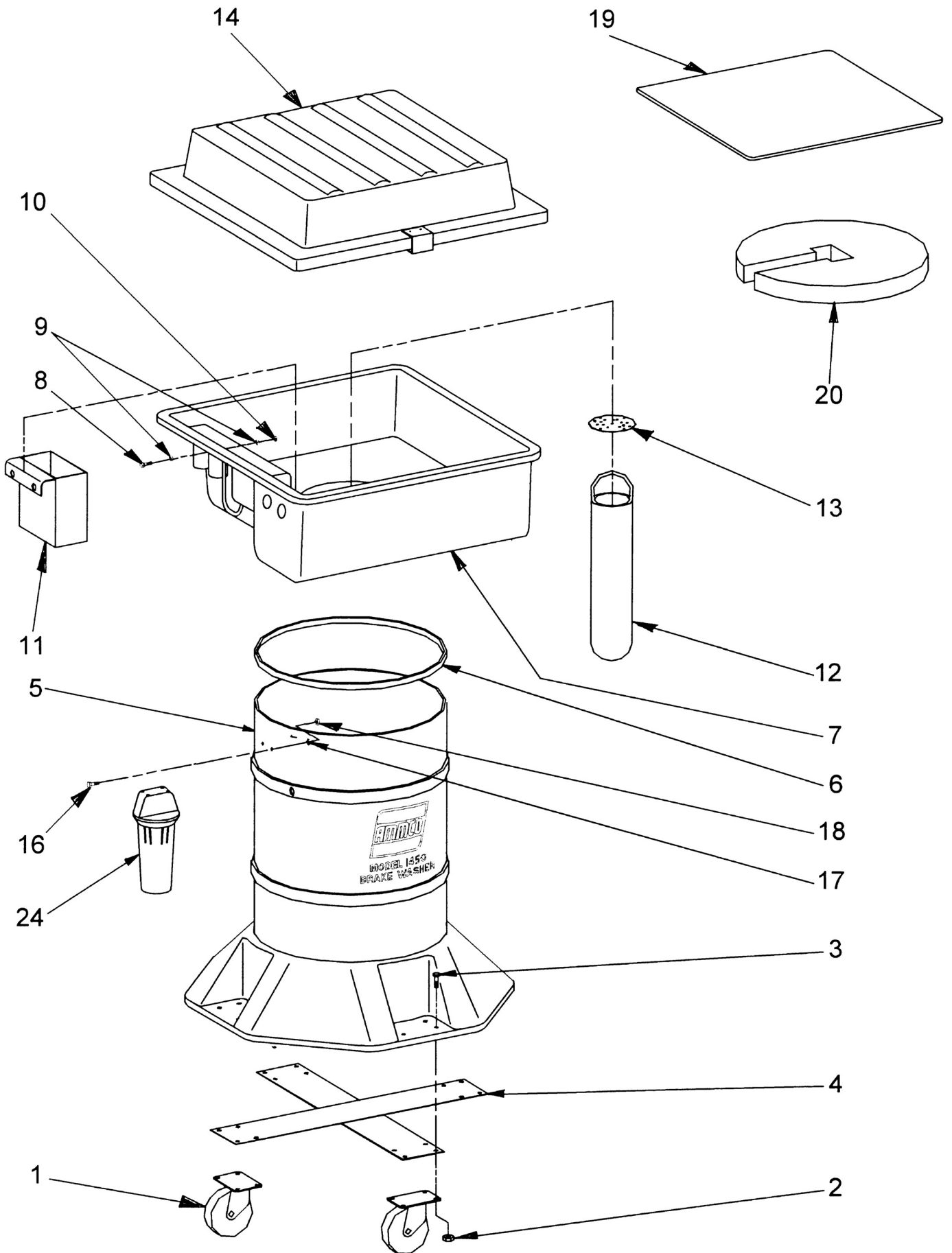



<u>ITEM #</u>	<u>PART #</u>	<u>DESCRIPTION</u>	<u>1350 QTY.</u>	<u>1450 QTY.</u>
1	629699	Caster	-	4
2	6182178	Nut, $\frac{5}{16}$ -18 Whiz Lock	-	16
3	6109503	Screw, $\frac{5}{16}$ -18 X $\frac{3}{4}$ Hex	-	16
4	629704	Support, Caster	-	2
5	629725	Base/Barrel Assy.	-	1
6	62968903	Ring, Clamp	-	1
7	629764	Pan Assembly	1	-
7	629724	Pan Assembly	-	1
8	604507	Screw, #10 - 24 X .5" Rd. Hd. Mach.	4	4
9	604789	Washer, #10	8	8
10	629795	Nut, #10 - 24 Hex Lock	4	4
11	629718	Basket, Parts	1	1
12	629700	Filter, Sock	1	1
13	640159	Grate, Drain	-	1
14	629701	Cover	1	-
14	629732	Cover	-	1
16	8301534	Screw, $\frac{1}{4}$ - 20 X 1" Hex Hd. Cap	-	2
17	620531	Washer, $\frac{1}{4}$	-	2
18	629737	Nut, $\frac{1}{4}$ - 20 Hex Lock	-	2
19	629751	Filter, Mat	1	-
20	629728	Filter	1	-
*21	629702	Boom, Oil	1	1
*22	629710	Cleaner, 1 Qt.	1	1
*23	625456	Bag, Disposal	1	1
24	95000014	Filter, Water	-	1
*25	629818	Sticker, Service	1	1
*26	640160	Sticker, Instruction	-	1

\*Items not shown



<u>ITEM #</u>	<u>PART #</u>	<u>DESCRIPTION</u>	<u>1350 QTY.</u>	<u>1450 QTY.</u>
1	629711	Connector, "Y" Type	1	1
2	625953	Fitting, ¼ Hose x ¼ NPT	1	1
3	629712	Fitting, ⅜ Hose x ¼ NPT	6	2
4	629717	Fitting, 1/4 NPT F x ⅜ Hose	1	1
6	629694	Brush	1	1
7	629819	Gun	2	2
8	629696	Pump	1	1
9	629697	Air Filter Assy.	1	1
10	629755	Clamp, Hose	8	5
11	625952	Strainer, Suction	1	1
12	629706	Cartridge, Water Filter -5 Micron nominal filtration rating	-	1
13	95000014	Filter, Water	-	1
14	629799	Spout, Flex	1	1
15	629729	Fitting, Bulk Hd.	1	-
16	62971402	Tubing, ¼ I.D. x 2"	1	1
17	62971401	Tubing, ¼ I.D. x 10"	1	1
18	62971301	Tubing, ⅜ I.D. x 60"	2	2
19	62971302	Tubing, ⅜ I.D. x 6"	1	1
20	95000015	Tubing, ⅜ I.D. x 28"	-	1
21	62971304	Tubing, ⅜ I.D. x 4.75"	1	-
22	62971305	Tubing, ⅜ I.D. x 3"	1	1
23	9500001501	Tubing, ⅜ I.D. x 10"	-	1
24	629743	Fitting	1	1
25	629756	Clamp, Hose	2	2
26	629761	Filter Element, Regulator	1	1
27	629762	Filter Element, Coalescing	1	1
28	629784	O-Ring	-	1
29	62971307	Tubing, ⅜ I.D. x 5 ¼"	1	-
30	640072	Clamp - Hose	3	3
*31	629735	Screw, #8 - 18 x ⅝" Self-Tap. Pan Hd.	-	4
*32	6296962	Pump Hose Barb, ¼ Hose	1	1
*33	6296961	Pump Hose Barb, ⅜ Hose	1	1
34	6296963	Pump Tubing, Conn., 10mm	-	1
35	85000342	Fitting ELL 1/4 NPT x 10mm TBE	-	1

\* Item not shown

