

SPX

ROBINAIR

Operating Manual



Model 34700Z / 17700Z
Recovery, Recycling, Recharging Unit

SAFETY DEFINITIONS: Follow all **WARNING**, **CAUTION**, **IMPORTANT**, and **NOTE** messages in this manual. These messages are defined as follows: **WARNING** means you may risk serious personal injury or death; **CAUTION** means you may risk personal injury, property damage, or unit damage; **IMPORTANT** means you may risk unit damage; and **NOTES** and **OPERATING TIPS** provide clarity and helpful tips. These safety messages cover situations ROBINAIR is aware of. ROBINAIR cannot know, evaluate, and advise you as to all possible hazards. You must verify that conditions and procedures do not jeopardize your personal safety.

DISCLAIMER: Information, illustrations, and specifications contained in this manual are based on the latest information available at the time of publication. The right is reserved to make changes at any time without obligation to notify any person or organization of such revisions or changes. Further, ROBINAIR shall not be liable for errors contained herein or for incidental or consequential damages (including lost profits) in connection with the furnishing, performance, or use of this material. If necessary, obtain additional health and safety information from the appropriate government agencies and the vehicle, refrigerant, and lubricant manufacturers.

WARNINGS



ALLOW ONLY QUALIFIED PERSONNEL TO OPERATE THE UNIT. Before operating the unit, read and follow the instructions and warnings in this manual. The operator must be familiar with air conditioning and refrigeration systems, refrigerants, and the dangers of pressurized components. If the operator cannot read English, operating instructions and safety precautions must be read and discussed in the operator's native language.

–Si el operador no puede leer inglés, las instrucciones de operación y las precauciones de seguridad deberán leerse y comentarse en el idioma nativo del operador.

–Si l'utilisateur ne peut lire l'anglais, les instructions et les consignes de sécurité doivent lui être expliquées dans sa langue maternelle.



PRESSURIZED TANK CONTAINS LIQUID REFRIGERANT. Do not overfill the internal storage vessel, because overfilling may cause explosion and personal injury or death. Do not recover refrigerants into nonrefillable containers; use only federally authorized refillable containers (DOT spec. 4BW or 4BA).



HOSES MAY CONTAIN LIQUID REFRIGERANT UNDER PRESSURE. Contact with refrigerant may cause personal injury. Wear protective equipment, including safety goggles. Disconnect hoses using extreme caution.



DO NOT BREATHE REFRIGERANT AND LUBRICANT VAPOR OR MIST. Exposure may cause personal injury, especially to the eyes, nose, throat, and lungs. Use the unit in locations with mechanical ventilation that provides at least four air changes per hour. If accidental system discharge occurs, ventilate the work area before resuming service.



DO NOT USE AN EXTENSION CORD. An extension cord may overheat and cause fire. If you must use an extension cord, use the shortest possible cord with a minimum size of 14 AWG.

TO REDUCE THE RISK OF FIRE, do not use the unit in the vicinity of spilled or open containers of gasoline or other flammable substances.



DO NOT USE COMPRESSED AIR TO PRESSURE TEST OR LEAK TEST THE UNIT OR VEHICLE AIR CONDITIONING SYSTEM. Some mixtures of air and R-134a refrigerant are combustible at elevated pressures. These mixtures are potentially dangerous and may result in fire or explosion causing personal injury or property damage.



USE THE 34700Z UNIT WITH R-134a REFRIGERANT ONLY. The unit is designed to recover, recycle, and recharge only R-134a refrigerant. Do not attempt to adapt the unit for another refrigerant. Do not mix refrigerant types through a system or in the same container; mixing of refrigerants will cause severe damage to the unit and the vehicle air conditioning system.



USE THE 17700Z UNIT WITH R-12 REFRIGERANT ONLY. The unit is designed to recover, recycle, and recharge only R-12 refrigerant. Do not attempt to adapt the unit for another refrigerant. Do not mix refrigerant types through a system or in the same container; mixing of refrigerants will cause severe damage to the unit and the vehicle air conditioning system.



HIGH VOLTAGE ELECTRICITY INSIDE THE UNIT HAS A RISK OF ELECTRICAL SHOCK. Exposure may cause personal injury. Disconnect the power before servicing the unit.

OPERATING NOTE: At temperatures exceeding 120° F / 49° C, wait 10 minutes between recovery jobs.

Table of Contents

Introduction	2
Technical Specifications	2
Keypad Functions	3
Glossary	3
Menu Functions	4
Setup	5
Select a Language	5
Select Operating Units	5
Add Oil to Vacuum Pump	5
Fill the Internal Tank	6
Operating Instructions	7
Recover Refrigerant	7
Evacuate the A/C System	8
Replenish A/C System Oil	9
Recharge the A/C System	10
Equalize Hoses Procedure	10
Operating Instructions — Automatic Function	12
Maintenance	14
General	14
Replacing the Filter-Drier	14
Electrical Protection	14
Changing Vacuum Pump Oil	15
Checking for Leaks	15
Filling the Internal Tank	16
Replacement Parts	16
Safety Precautions	Inside Front Cover
Warranty	Inside Back Cover

⚠ CAUTION: This manual contains important safety procedures concerning the operation, use, and maintenance of this product. Failure to follow the instructions contained in this manual may result in serious injury.

If you are unable to understand the contents of this manual, please bring it to the attention of your supervisor. Do NOT operate this equipment unless you have read and understood the contents of this manual.

Introduction

The 34700Z model is used on R-134a vehicles; the 17700Z model is used on R-12 vehicles. Both models are designed to be compatible with existing service equipment and standard service procedures. Both models are UL-listed, single-pass systems that meet SAE specifications for recycled refrigerant. Follow the SAE-J2210 recommended service procedure for the containment of R-134a; follow the SAE-J1991 recommended service procedure for the containment of R-12.

The unit includes a 6 cfm (142 l/m) Robinair high vacuum pump for fast thorough evacuation. The recovery compressor is *not* a vacuum pump. The compressor pulls the A/C system to a partial vacuum only; use the unit's vacuum cycle to remove moisture from the A/C system. (We recommend a minimum 15-minute vacuum, or follow the vehicle manufacturer's recommendation.)

Note : R-134a systems require special oils. Refer to the A/C system manufacturer's service manual for oil specifications.

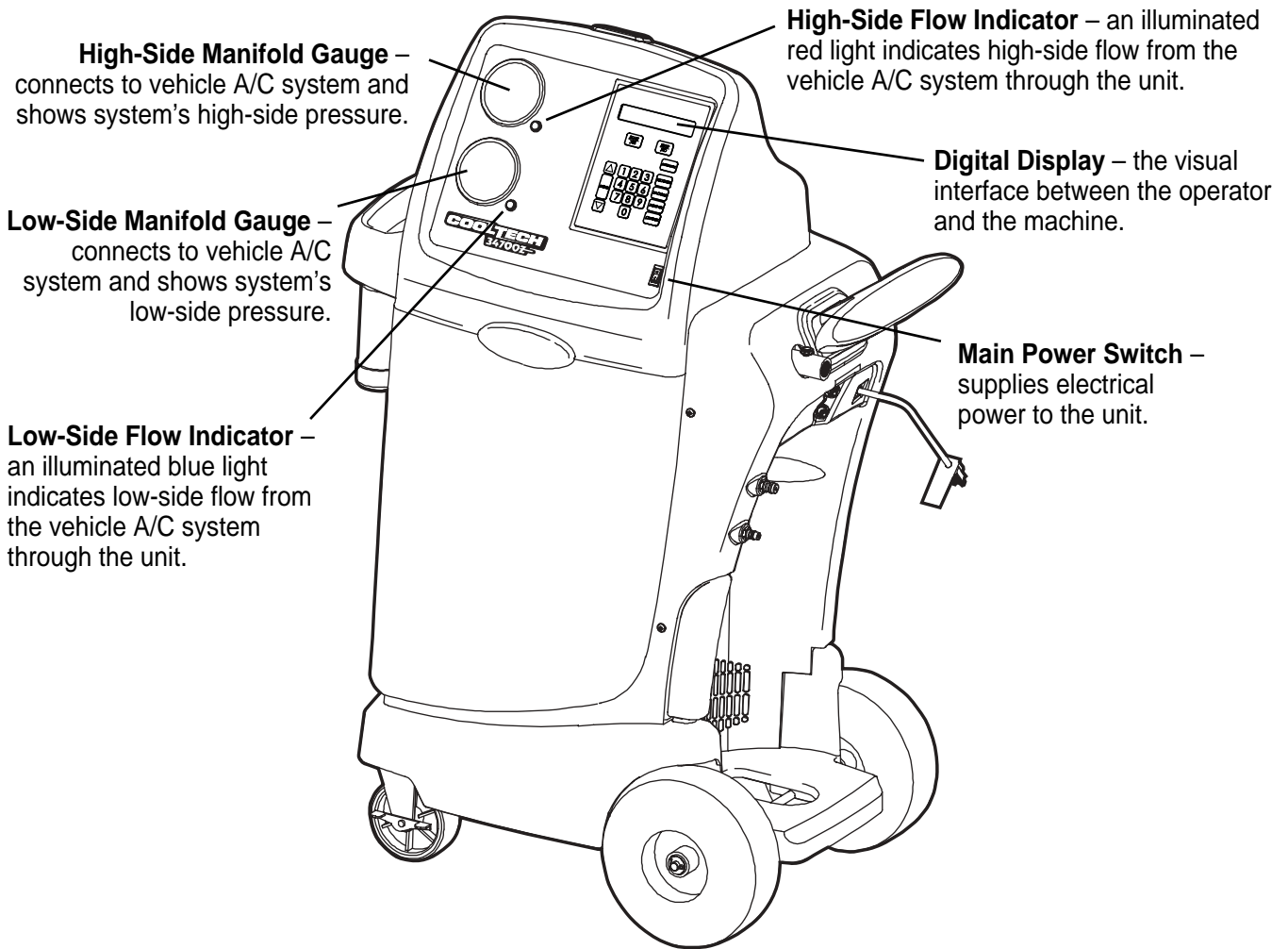

Technical Specifications

Voltage 115V, 60 Hz
Operating Range 50° to 120° F (11° to 49° C)
Filter-Drier 43 cu. in. spin-on type

Pump Free-Air Displacement 6 cfm (142 l/m)
Dimensions 50" H x 34" W x 23" D
 (127 cm x 86.4 cm x 58.4 cm)

Keypad Functions

START YES	START / YES begins or resumes a function, or answers a query.
STOP NO	STOP / NO terminates or pauses a function, or answers a query.
MENU	MENU displays the selection menu.
	UP or DOWN arrows are used for scrolling through menu items.
RECOVER	RECOVER activates the recovery sequence.
VACUUM	VACUUM activates the vacuum and automatic recycling sequence, followed by an option to activate a vacuum leak check.
CHARGE	CHARGE charges the vehicle A/C system with a programmed amount of refrigerant.
INJECT OIL	INJECT OIL injects oil into the vehicle A/C system.
AUTOMATIC	AUTOMATIC activates a menu which prompts the user through setting up an automatic recover / vacuum / vacuum leak check / charge sequence.

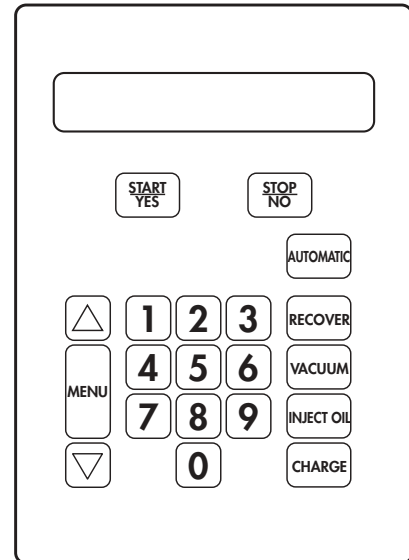

Keypad

Glossary

A/C System : The vehicle air conditioning system being serviced.

Internal Storage Vessel : The refillable refrigerant storage vessel designed specifically for this unit; 30 lb. (14 kg).

Source Tank : A disposable tank of new refrigerant used to refill the internal storage vessel; not included.

Unit : The 34700Z or the 17700Z.

Introduction

Menu Functions

1. Press the **MENU** button on the keypad.
2. Press the **UP** or **DOWN** arrow key to scroll through the menu choices shown on the second line of the display :
SELECT LANGUAGE
VERSION X.XX
CHANGE DEFAULTS
CHANGE VACUUM PUMP OIL
VACUUM OIL TIME
CHANGE FILTER
FILTER CAPACITY
RECYCLE ONLY
TANK REFILL
SELECT UNITS IMPERIAL / METRIC
3. Press **START / YES** to make a choice from the menu. Press **STOP / NO** to pause during any process, and **STOP / NO** a second time to exit a process.

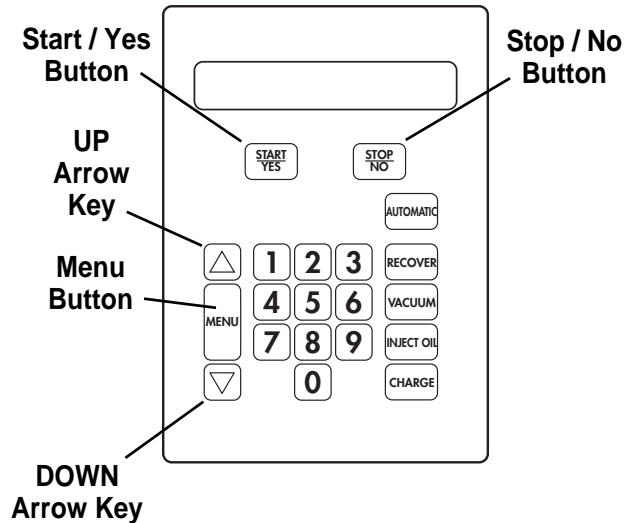

Menu Choice : Select Language

Operator may choose to have prompts displayed in one of three languages : English, Spanish, or French.

Menu Choice : Version X.XX

Displays the revision level of the software in the unit.

Menu Choice : Change Defaults

For service center use only.

Menu Choice : Change Vacuum Pump Oil

For maximum vacuum pump performance, change vacuum pump oil after every 10 hours of operation. Refer to the instructions outlined in the Maintenance section under *Changing Vacuum Pump Oil*.

Menu Choice : Vacuum Oil Time

Displays how long the vacuum pump has operated since the last oil change. The display resets to zero after a vacuum pump oil change has been completed. Refer to the instructions outlined in the Maintenance section under *Changing Vacuum Pump Oil*.

Menu Choice : Select Units

Operator may choose to have test results displayed in Imperial (English) or Metric units.

Menu Choice : Change Filter

The filter-drier removes acid, particulates, and moisture from the refrigerant. Change the filter-drier after 150 lbs. (68 kg) of refrigerant has been filtered. Refer to the instructions outlined in the Maintenance section under *Replacing the Filter-Drier*.

Menu Choice : Filter Capacity

Displays how many pounds or kilograms of refrigerant have been recovered since the last filter change. The display resets to zero after a filter-drier change. Refer to the instructions outlined in the Maintenance section under *Replacing the Filter-Drier*.

Menu Choice : Recycle Only

Manual recycling may be necessary if excessive air and/or moisture has been recovered from the vehicle A/C system.

Menu Choice : Tank Refill

This menu item is used to transfer refrigerant from the source tank to the internal storage vessel (ISV). Refer to the instructions outlined in the Maintenance section under *Filling the Internal Tank*.

The first time the unit is powered up, it will display the initial setup mode.

1. Connect the power cord to the back of the unit, and plug the other end into a correct voltage outlet.
2. Turn on the main power switch.

Select a Language

The operator may choose to have prompts displayed in one of three languages : English, Spanish, or French.

1. Use the **UP** or **DOWN** arrow key to toggle through the choices for English, Spanish, or French. See Figure 1.
2. Press **START / YES** to select the displayed language choice.

Select Operating Units

The operator may choose to have test results displayed in Imperial (English) units or Metric units.

1. Use the **UP** or **DOWN** arrow key to toggle through the choices for IMPERIAL (English) UNITS or METRIC UNITS.
2. Press **START / YES** to select the displayed operating unit choice.

Add Oil to Vacuum Pump

IMPORTANT : The vacuum pump is shipped without oil in the reservoir. Failure to add oil to the vacuum pump will damage the pump.

1. Remove the plug from the vacuum pump fill port. See Figure 2.
2. Attach the flexible tube and cap to the oil bottle, and pour six (6) ounces of vacuum pump oil into the vacuum pump fill port.
3. Press and release the **START / YES** key. While the vacuum pump is running, slowly add oil until the level rises to the center of the reservoir's sight glass.
4. Press the **STOP / NO** key to stop the vacuum pump, and install the plastic plug in the vacuum pump fill port.

IMPORTANT : R-134a systems have special fittings (per SAE specifications) to avoid cross-contamination with R-12 systems. DO NOT adapt your unit for a different refrigerant — system failure will result.

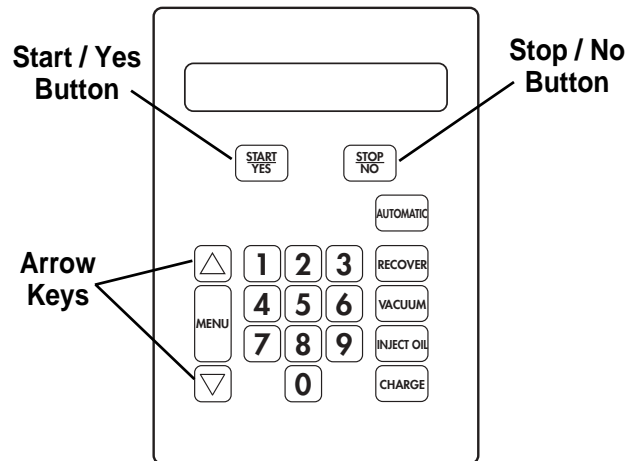

Figure 1
Keypad

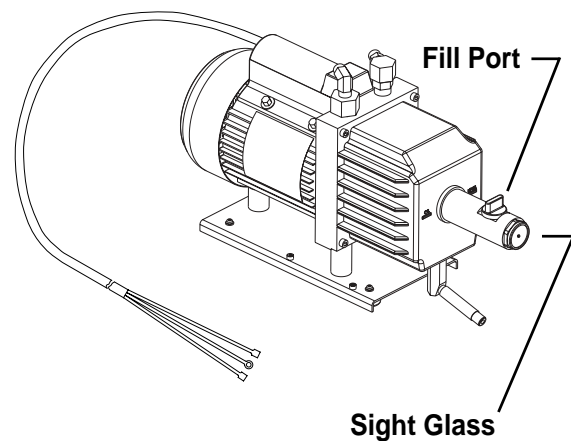

Figure 2
Vacuum Pump

Setup

Fill the Internal Tank

1. Connect the service hoses to the unit, and press **START / YES**. See Figure 3.
2. Connect the fill hose to a full source tank.
3. Open the source tank valve.
4. Install the source tank on the unit, and secure the tank using the tank strap.

Note: If using a refillable tank, install the tank upside down and connect the fill hose to the vapor valve.

5. Press **START / YES**, and the unit will automatically run a 5-minute vacuum to clear all internal air.
6. After the vacuum pump shuts off, the unit automatically begins filling the internal storage vessel. Add at least 8 lbs. (3.6 kg) of refrigerant to ensure enough refrigerant is available for charging.

This process takes 15–20 minutes. The unit stops when a sufficient amount of refrigerant has been transferred to the internal tank, or when the source tank is empty.

Press **STOP / NO** to pause. Press **STOP / NO** again to exit, or **START / YES** to resume.

7. When the fill process is complete, press **STOP / NO** to exit. The unit is ready for operation.

Note: There is no need to calibrate the scale; it is calibrated at the factory.

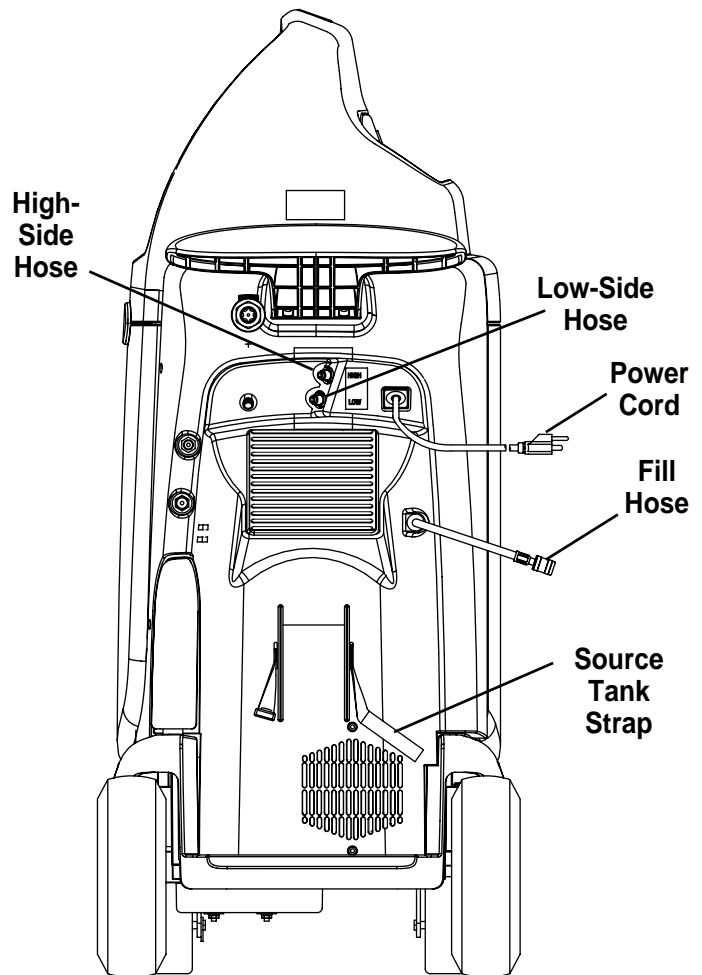

Figure 3
Side View

Operating Instructions

Recover Refrigerant

1. Empty the oil drain bottle located on the right-hand side of the unit, if necessary, or make note of the current oil level. See Figure 4.
2. Connect the high- and low-side hoses to the vehicle A/C system.
3. Open the coupler valves on the hoses.
4. Press **RECOVER**.
5. When the system has recovered to a vacuum level of approximately 13 in. Hg, the compressor automatically shuts off. The unit goes into an automatic oil drain—this may require 90 seconds to complete.
6. After the oil drain is complete, the display alternates between :

RECOVER COMPLETE
CHECK OIL BOTTLE
RECOVERED XX.XX LBS. (X.XX KG)

Note: The displayed recovered weight can vary depending on ambient conditions, and should not be used as an indicator of scale accuracy.

7. Check the oil drain bottle, and note the amount of oil that was removed from the A/C system. This is the amount of oil that must be charged into the A/C system after evacuation is complete.
8. A pressure rise may occur if there was freezing in the A/C system during recovery.

To ensure complete recovery of refrigerant, the unit will automatically wait 5 minutes and monitor for a rise in pressure above 0 in. Hg.

If a rise occurs, the unit will repeat the recovery process, and wait another 2 minutes for a pressure rise above 0 in. Hg.

The unit will continue to recover and wait until it maintains a vacuum for 2 minutes.

Note: The high- and low-side lights on the control panel will remain ON until the recovery is complete.

9. Press **STOP / NO** to exit.

Recovery is complete. You are now ready to make repairs to the A/C system, if necessary, or advance to the evacuation process.

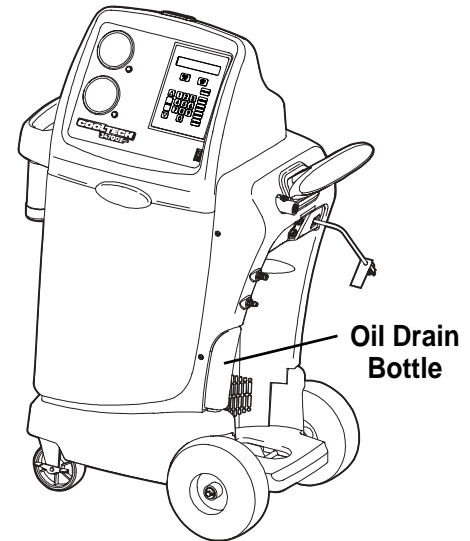

Figure 4

Operating Tips

- After selecting the **RECOVER** function, if system pressure is below 25 psi, the display reads

LOW SYSTEM PRESSURE

until pressure increases, or the **START / YES** button is pressed. Verify the high- and low-side hoses are connected and the coupler valves are open. Press **STOP / NO** to exit at this point.

- After selecting the **RECOVER** function, if 150 lbs. (68 kg) or more of refrigerant has been recovered since the last filter-drier change, the display reads

FILTER WEIGHT XXX LB (XX KG)
CHANGE FILTER NOW?

Refer to the Filter Change Procedure in Maintenance section of this manual for details regarding replacing the filter.

- After selecting the **RECOVER** function, if the unit has refrigerant in the low-side plumbing, it begins a clearing process and displays

CLEARING IN PROGRESS

If you wish to skip the clearing operation, or stop the clearing prematurely, press **START / YES**.

Operating Instructions

Evacuate the A/C System

1. Ensure service hoses are connected, and the coupler valves are OPEN.
2. Press **VACUUM**.
3. Press **START / YES** to accept the default evacuation time of 15 minutes, or enter the desired vacuum time using the number keys, and press **START / YES**.

The unit pulls a vacuum on the vehicle A/C system to remove any air and boil off any moisture that may be present in the system.

IMPORTANT : Evacuate the system for at least 15 minutes, or follow the A/C system manufacturer's specifications, to ensure adequate moisture and contaminant removal.

4. The unit will give you the option of doing a leak check after evacuation.
Press **START / YES** to perform the leak check.
Press **STOP / NO** to skip the leak check and begin evacuation.
5. The unit evacuates the A/C system and stops when the specified time has elapsed.
Press **STOP / NO** to pause the process. Press **START / YES** to resume, or **STOP / NO** again to exit.

You are now ready to replenish the A/C system oil, if necessary, or to recharge the system with refrigerant.

Operating Tips

- *If the vacuum pump has run for 10 or more hours without an oil change, the unit displays*

VACUUM OIL TIME XX:XX
CHANGE OIL NOW?

Refer to the Maintenance section of this manual for instructions regarding Changing Vacuum Pump Oil.

- *Before the unit begins evacuating the A/C system, it checks for any pressure in the system that might damage the vacuum pump. If pressure is detected, the unit displays*

PRESSURE EXISTS
PRESS ANY KEY TO EXIT

Press any key to exit, and recover refrigerant before proceeding.

- *If a leak check was selected at the end of vacuum, and a leak is detected, the unit displays*

LEAK CHECK FAILED
PRESS ANY KEY TO EXIT

Press any key to exit the evacuation, perform needed repairs, and repeat evacuation.

- *To ensure an accurate leak test, it is imperative that a thorough recovery and evacuation of the system has been performed. During the recovery process, cold spots can develop in the automotive system. Pockets of refrigerant in desiccant and in system oil will continue to vaporize as the A/C system temperature equalizes toward ambient. As this occurs, A/C system pressure will increase, which may be interpreted by the unit as a leak.*

This will vary somewhat with ambient temperature conditions.

Replenish A/C System Oil

Oil may be replenished through the high side after the vacuum function, or with an oil inject tool after charging the vehicle.

IMPORTANT : To prevent damage to equipment, charge only the amount of oil that was removed from the A/C system during the recovery process. If no oil was removed from the A/C system during recovery, DO NOT charge any oil into the A/C system.

Empty the oil drain bottle before recovering an A/C system to prevent an inaccurate oil charge.

1. Refer to the vehicle service manual to determine the correct oil for the A/C system being serviced.
2. Check the oil drain bottle to determine the amount of oil that was removed. See Figure 5.
3. Adjust the o-ring around the oil injector bottle to the required oil charge level.

For example, if the bottle's oil level is at 4 ounces, and you need 1/2 ounce of oil to replenish the A/C system, place the o-ring at the 3-1/2 ounce level.

4. Attach the oil injector bottle to the unit.
5. Press the **INJECT OIL** button. The unit looks for pressure in the hoses, and temporarily displays **EQUALIZING PRESSURE**.
6. When prompted, press and hold **INJECT OIL** until the oil level in the oil injector bottle reaches the o-ring.
7. Press **STOP / NO** after the oil inject is complete to recharge the system with refrigerant. The display will prompt into the charge mode. (Charge mode after injecting oil will only allow a high-side charge.)

Note: You must recharge the A/C system with refrigerant at this time to ensure all the oil is delivered.

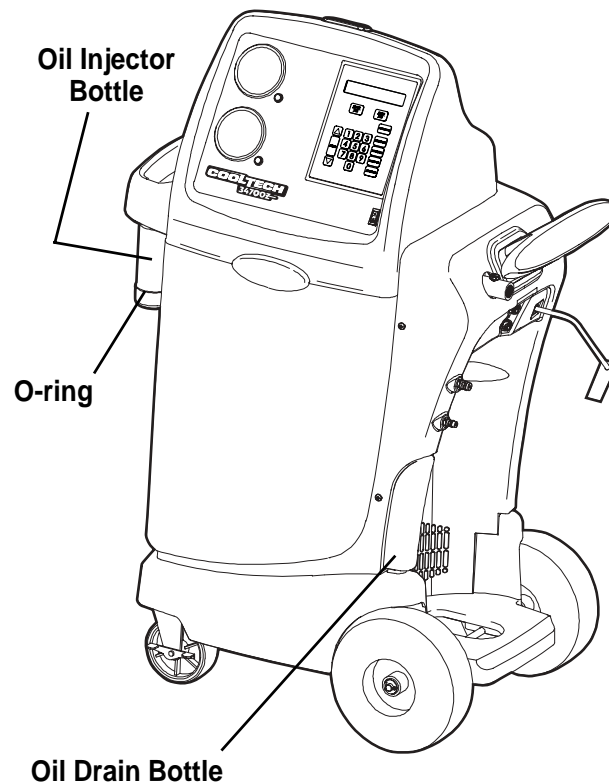

Figure 5

Operating Instructions

Recharge the A/C System

If an oil inject has already been performed, you may skip steps 1 and 2.

1. Press **CHARGE**.
2. Select **START / YES**, to perform an oil inject; select **STOP / NO** to skip the oil inject.
3. Press **CHARGE** to toggle between a high-side or low-side charge.

Note: Charge mode after injecting oil will only allow a high-side charge.

4. Accept either the default weight by pressing **START / YES**, or type in a weight, using the number keys, and press **START / YES**.
5. After a valid charge weight is entered, the display reads

CHARGE IN PROGRESS / DO NOT DISTURB
CHARGED=X.XX LBS. (X.XX KG)

Moving or bumping the unit at this point may result in an incorrect reading.

6. When the charge is complete, the display reads

EQUALIZE HOSES?
X.XX LBS (KG) CHARGED

Press **START / YES** to equalize hoses. Press **STOP / NO** to resume charging.

Equalize Hoses

After the charge is complete, the user has the option to equalize the pressure in the hoses to ensure a more accurate charge. If the pressure in the high side and low side is not equal after charge, then it may be necessary to follow this procedure to ensure all the liquid refrigerant trapped in the service hoses is transferred to the vehicle A/C system.

1. After the charge is complete, the user has the option to equalize the pressure in the hoses.

Selecting **START / YES** prompts the user through the **EQUALIZE HOSES** procedure.

Select **STOP / NO** to resume charging.

2. Close the high-side coupler valve.

Operating Tips

After selecting the **CHARGE** function and entering a desired weight, if the weight entered will leave less than 3 lbs. (1.36 kg) of refrigerant in the internal tank after charge, the charge function will not start. The display reads

INSUFFICIENT REFRIG.
PRESS ANY KEY TO EXIT

Refer to the Maintenance section of this manual for instructions on Refilling the Internal Tank.

Slow Charge Procedure

If, during the **CHARGE** cycle, the weight fails to charge 0.05 lbs. (0.02 kg) in 30 seconds, it may be necessary to use the vehicle to pull the charge into the A/C system. The unit “beeps” while the display alternates between

CHARGE HAS SLOWED
RETRY? (YES/NO)

1. If **START / YES** is pressed, the unit will ask if you want to use the vehicle to pull in the charge.

Selecting **START / YES** will prompt the user through the slow charge procedure.

Selecting **STOP / NO** will resume charging.

2. Place the vehicle gear selector in park or neutral, with the emergency brake ON.
3. Start the vehicle. Set the A/C system to its maximum setting.
4. Press **START / YES**. The unit charges out of the low-side inlet only, allowing the vehicle’s compressor to pull the refrigerant into the A/C system. When the charge is complete, the display shows

EQUALIZE HOSES?
X.XX LBS (KG) CHARGED

Equalize Hoses contd.

3. Place the vehicle gear selector in park or neutral, with the emergency brake ON.
4. Start the vehicle. Set the A/C system to its maximum setting.
5. Press **START / YES**. The unit internally connects the low- and high-side hoses, allowing the vehicle's compressor to pull the refrigerant into the A/C system. When the charge is complete, the display shows

CLEAR COMPLETE
X.XX LBS (KG) CHARGED

6. Close the low-side coupler valve. Remove the service hoses from the A/C system. Shut OFF the vehicle.

The A/C system is now ready for use.

⚠ WARNING : To prevent personal injury, verify the vehicle is in park or neutral with the emergency brake ON before starting the engine. Never run a vehicle without adequate ventilation in the work area.

Operating Instructions – Automatic

The automatic function allows a user to program an automatic recovery, vacuum, leak test, and / or charge sequence. The user may choose to skip any step in the automatic operation during the programming. A total automatic sequence may take an hour to complete.

Note: Oil recovered during the recovery cycle can be injected by the user before the charge cycle, or can be manually injected into the vehicle after charge using a separate oil injection tool.

1. Connect the high- and low-side service hoses to the A/C system, and open the coupler valves on the hoses.
2. Press **AUTOMATIC**.
3. The unit will ask if a recovery is needed.
Press **STOP / NO** to skip the recovery cycle.
Press **START / YES** to accept.
4. The unit will ask if vacuum is needed for evacuation.
Press **STOP / NO** to skip the vacuum cycle.
Press **START / YES** to accept.
If **START / YES** is selected, press the **START / YES** key again to accept the default evacuation time of 15 minutes, or enter the desired evacuation time by using the number keys, and press **START / YES** again.
5. If vacuum has been selected, the unit will ask if a leak check is needed.
Press **STOP / NO** to skip the leak check.
Press **START / YES** to accept.
6. The unit will ask if a charge is needed.
Press **STOP / NO** to skip the charge cycle.
Press **START / YES** to accept a charge. Press **CHARGE** to toggle between high- or low-side charge, or both.
Accept either the default weight by pressing **START / YES**, or type in a desired weight using the number keys, and then press **START / YES**.
7. The display will show an overview of all the tests that were selected. Press **START / YES** to begin the automatic sequence.

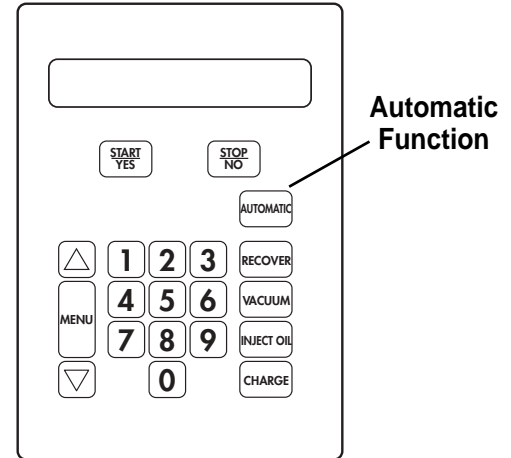

Operating Tips

If the weight entered will leave less than 3 lbs. (1.36 kg) of refrigerant in the internal tank after charge, the charge function will not start. The display reads

**INSUFFICIENT REFRIG.
PRESS ANY KEY TO EXIT**

Refer to the Maintenance section of this manual for instructions on Refilling the Internal Tank.

Operating Instructions – Automatic

Automatic Function contd.

Note :

- *If a high-side charge has been selected, before charging, the automatic sequence will pause and “beep” for 30 seconds to allow the user to inject oil, if desired. See Replenishing the A/C System Oil instructions in this manual.*
- *After charging is complete, the user also has the option to equalize the hoses. Refer to the Equalize Hoses Procedure in this manual.*
- 8. When the sequence is complete, the display will show the amount of refrigerant that was recovered and charged.
- 9. Close the high- and low-side coupler valves, and remove the service hoses from the A/C system.
- 10. If any oil was recovered during the recovery cycle, and the user did not inject oil before the charge cycle, manually inject oil into the A/C system at this time using an oil injection tool.

Operating Tips

- *If problems are encountered during the automatic sequence, the unit will “beep” three times, and the control panel readout will pinpoint the problem encountered. The sequence will remain paused until the user enters a decision regarding how to proceed.*
- *Before the unit begins evacuating the A/C system during the automatic sequence, it checks for any pressure in the system that might damage the vacuum pump. If pressure is detected, the unit displays*

**PRESSURE EXISTS
PRESS ANY KEY TO EXIT**

Press any key to exit the automatic sequence.

- *If a leak check was selected at the end of vacuum, and a leak is detected, the unit displays*

**LEAK CHECK FAILED
PRESS STOP TO EXIT
PRESS START TO CONTINUE**

Press stop to exit the automatic sequence, and perform needed repairs. Press start to continue the automatic sequence despite the failed leak check.

- *To ensure an accurate leak test, it is imperative that a thorough recovery and evacuation of the system has been performed. During the recovery process, cold spots can develop in the automotive system. Pockets of refrigerant in desiccant and in system oil will continue to vaporize as the A/C system temperature equalizes toward ambient. As this occurs, A/C system pressure will increase, which may be interpreted by the unit as a leak.*

This will vary somewhat with ambient temperature conditions.

Maintenance

General Maintenance

1. On a regular basis, wipe off the unit using a clean cloth to remove grease and dirt.
2. Periodically check internal components for leaks; over time, fittings can loosen as the unit is moved. Open the door panel, and trace lines using a leak detector. Check connections on the back of the unit also. Tighten any loose fittings or connections you may find.

Replacing the Filter-Drier

The filter-drier on this unit is designed to trap acid and particulates, and to remove water from refrigerant. Change the filter-drier after every 150 lbs. (68 kg) of refrigerant has been recycled to ensure adequate moisture and contaminant removal. (The unit will prompt the user to change the filter-drier after 150 lbs. of refrigerant has been recycled.)

IMPORTANT : For best results, use Robinair filter-driers. All performance tests and claims are based on using the filter-drier specified for this unit. Using a different filter-drier may affect the performance of the unit and test results. Order Robinair No. 34724.

1. Press **MENU**.
2. Scroll through the menu to **CHANGE FILTER**, and press **START / YES**. The unit will begin clearing the filter.
3. When clearing is complete, the display reads **TURN UNIT OFF AND REPLACE FILTER**. Turn OFF main power, and unplug the machine.
4. Open the unit door, and replace the old filter with a new filter.
5. Close the unit door, plug in the machine, and turn ON main power.

The filter-drier change is now complete.

Electrical Protection

The unit is equipped with two circuit breakers (15 amp and 3 amp) on the back panel. If either breaker trips, its button will pop out. A tripped 3 amp breaker will render the fan inoperable; a tripped 15 amp breaker will cause the unit to lose all power.

Press the circuit breaker button to reset.

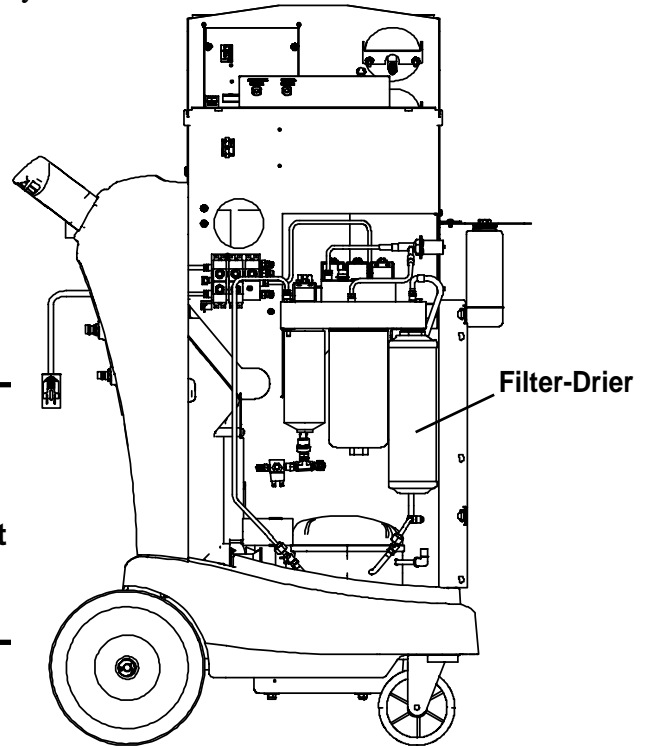

Rear View (without shroud)

Operating Tips

The menu item FILTER CAPACITY displays how many pounds or kilograms of refrigerant have been recovered since the last filter change :

FILTERED=XXX LBS (KG).

The amount filtered resets to zero after a the filter-drier has been changed.

Changing Vacuum Pump Oil

For maximum vacuum pump performance, change the vacuum pump oil after every 10 hours of operation. The unit will prompt the user to perform a vacuum pump oil change after 10 hours of operation.

1. Press **MENU**.
 2. Use the arrow keys to select **CHANGE VACUUM PUMP OIL**, and press **START / YES** to begin.
 3. Allow the vacuum pump to run until it automatically stops (about 2 minutes).
 4. Remove the plastic plug on the oil fill port of the vacuum pump.
 5. Remove the oil drain cap from the vacuum pump, and drain the oil into a suitable container for disposal. Replace the oil drain cap.
 6. Attach the flexible tube and cap to the oil bottle, and pour six (6) ounces of vacuum pump oil into the fill port.
 7. Press **START / YES**. While the vacuum pump is running, slowly add oil until the level rises to the center of the reservoir's sight glass.
 8. Press **STOP / NO**.
 9. Replace the plastic plug on the fill port.
- The unit is now ready for operation.

Checking for Leaks

Check the unit for leaks every three months, or as specified by local or state laws.

1. Turn off **MAIN POWER**.
2. Disconnect the power cord from the outlet.
3. Open the rear door.
4. Remove the top cover and front panel.
5. Use a leak detector to probe all connections for refrigerant leaks. Tighten fittings if a leak is indicated.
6. Reassemble the body panels, and close the rear door.

Inspect the unit periodically for leaks. The manufacturer does not reimburse for lost refrigerant.

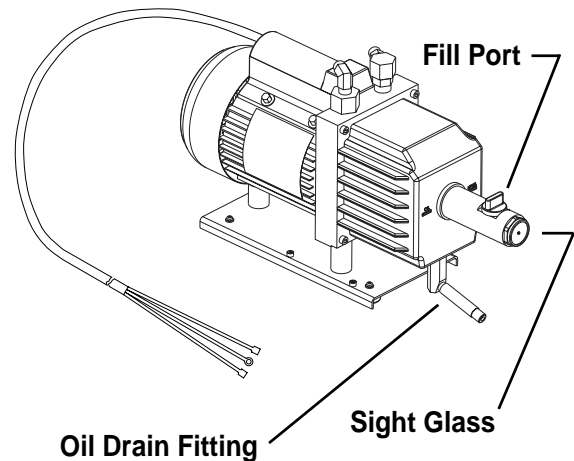

Operating Tips

The menu item **VACUUM OIL TIME** displays how long the vacuum pump has operated since the last oil change :

OIL TIME=XX:XX

The time resets to zero after a vacuum pump oil change has been completed.

Review current local, state, and federal statutes, cases, laws, and regulations to determine the correct disposal procedure for pump oil. It is the responsibility of the user to determine if a material is a hazardous waste at the time of disposal. Ensure you are in compliance with all applicable laws and regulations.

Maintenance

Filling the Internal Tank

This menu item is used to transfer refrigerant from the source tank to the internal storage vessel (ISV).

1. Connect the fill hose to a full source tank.
2. Open the source tank valve.
3. Install the source tank on the unit, and secure the source tank using the tank strap.

Note: If using a refillable tank, install the tank upside down and connect the fill hose to the vapor valve.

4. Press **Menu**, and use the **UP** or **DOWN** arrow keys to select TANK REFILL.
5. Press **START / YES**, and the unit will automatically fill the internal storage vessel until it contains 15 lbs. of refrigerant, or until the source tank is empty.

Press **STOP / NO** to pause. Press **STOP / NO** again to exit, or **START / YES** to resume.

Note : If a refrigerant source tank remains connected to the unit during normal operation, the correct amount of refrigerant will be automatically maintained in the ISV. The ISV may be manually refilled, if necessary.

6. When the fill process is complete, press **STOP / NO** to exit. The unit is ready for operation.

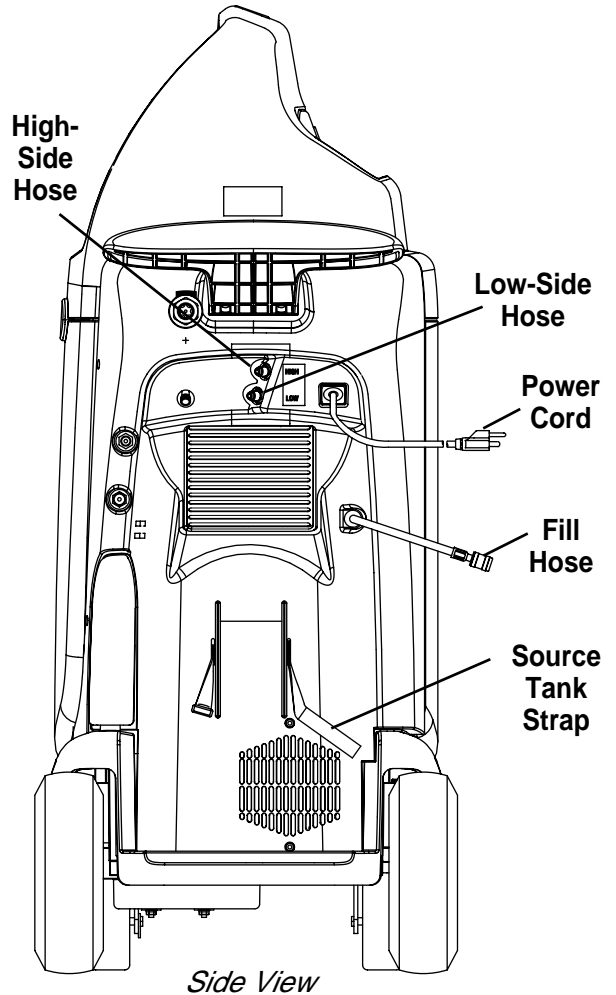

Replacement Parts

Component	34700Z Replacement Part No.	17700Z Replacement Part No.
96" Red Hose	63096	68396A
96" Blue Hose	62121	68296A
Filter-Drier	34724	34724
Low-Side Coupler	18190A	
High-Side Coupler	18191A	
Vacuum Pump Oil (case of 12 quarts)	13203	13203
Vacuum Pump Oil (case of 4 gallons)	13204	13204
Maintenance Kit	13172	13172

Robinair Limited Warranty Statement

Rev. November 1, 2005

This product is warranted to be free from defects in workmanship, materials, and components for a period of one year from date of purchase. All parts and labor required to repair defective products covered under the warranty will be at no charge. The following restrictions apply:

1. The limited warranty applies to the original purchaser only.
2. The warranty applies to the product in normal usage situations only, as described in the Operating Manual. The product must be serviced and maintained as specified.
3. If the product fails, it will be repaired or replaced at the option of the manufacturer.
4. Transportation charges for warranty service will be reimbursed by the factory upon verification of the warranty claim and submission of a freight bill for normal ground service. Approval from the manufacturer must be obtained prior to shipping to an authorized service center.
5. Warranty service claims are subject to authorized inspection for product defect(s).
6. The manufacturer shall not be responsible for any additional costs associated with a product failure including, but not limited to, loss of work time, loss of refrigerant, cross-contamination of refrigerant, and unauthorized shipping and/or labor charges.
7. All warranty service claims must be made within the specified warranty period. Proof-of-purchase date must be supplied to the manufacturer.
8. Use of recovery/recycling equipment with unauthorized refrigerants or sealants will void warranty.
 - Authorized refrigerants are listed on the equipment or are available through the Technical Service Department.
 - The manufacturer prohibits the use of the recovery/recycling equipment on air conditioning (A/C) systems containing leak sealants, either of a seal-swelling or aerobic nature.

This Limited Warranty does NOT apply if:

- The product, or product part, is broken by accident.
 - The product is misused, tampered with, or modified.
 - The product is used for recovering or recycling any substance other than the specified refrigerant type. This includes, but is not limited to, materials and chemicals used to seal leaks in A/C systems.
-

CONVERSION TABLE

OZ.	LBS.
0.5	0.03
1.0	0.06
1.5	0.09
2.0	0.13
2.5	0.16
3.0	0.19
3.5	0.22
4.0	0.25
4.5	0.28
5.0	0.31
5.5	0.34
6.0	0.38
6.5	0.41
7.0	0.44
7.5	0.47
8.0	0.50
8.5	0.53
9.0	0.56
9.5	0.59
10.0	0.63
10.5	0.66
11.0	0.69
11.5	0.72
12.0	0.75
12.5	0.78
13.0	0.81
13.5	0.84
14.0	0.88
14.5	0.91
15.0	0.94
15.5	0.97
16.0	1 lb.



Visit our web site at
www.robinair.com

or

**Call our Toll-Free
Technical Support Line at
800-822-5561**

in the continental U.S. or Canada.

In all other locations, contact your local distributor. To help us serve you better, please be prepared to provide the model number, serial number, and date of purchase of your unit.

To validate your warranty, complete the warranty card attached to your unit, and return it within ten days from date of purchase.

NATIONWIDE NETWORK OF AUTHORIZED SERVICE CENTERS

If your unit needs repair or replacement parts, contact the service center in your area. For help in locating a service center, call the toll-free technical support line.

Due to ongoing product improvements,
we reserve the right to change design,
specifications, and materials without notice.

The 34700Z/17700Z units are designed to meet all applicable agency certifications, including Underwriter's Laboratories, Inc., SAE Standards, and CUL.

Certain state and local jurisdictions dictate that using this equipment to sell refrigerant by weight may not be permitted. We recommend charging for any A/C service by the job performed.

This weight scale provides a means of metering the amount of refrigerant needed for optimum A/C system performance as recommended by OEM manufacturers.

SPX **ROBINAIR**

*SPX Corporation
655 Eisenhower Drive
Owatonna, MN 55060-0995 USA
Tech Services: 1-800-822-5561
Fax: 1-412-690-2001
Customer Service: 1-800-533-6127
Fax: 1-800-322-2890
Web site: www.robinair.com*