



ROBINAIR

Operating Manual

Series
34700/34701/34704
for R-134a

Series
17700A/17701A
for R-12

Recovery/Recycling/Recharging Unit

LISTED



80S2

Recycling Equipment Design
Certified by Underwriters
Laboratories Inc.,® for
Compliance with SAE-J2210
(1991) for HFC-134a and
SAE-J1991 (1989) for CFC-12

ROBINAIR

Refrigerant Recovery, Recycling and Recharging Station

Series: 17700A/17701A
and 34700/34701/34704
Refrigerants: R-12 (17700A/17701A)
or R-134a (34700/34701)

⚠ WARNING ⚠

PRESSURIZED TANK CONTAINS LIQUID REFRIGERANT. OVERFILLING OF THE TANK MAY CAUSE VIOLENT EXPLOSION AND POSSIBLE INJURY OR DEATH. Safety devices require the use of only authorized refillable refrigerant tanks. Refer to the instruction manual for tank specifications and ordering information. Do not recover refrigerants into a non-refillable storage container! Federal regulations require refrigerant to be transported only in containers meeting DOT spec. 4BW or DOT spec. 4BA.

ALL HOSES MAY CONTAIN LIQUID REFRIGERANT UNDER PRESSURE. Contact with refrigerant may cause injury. Wear proper protective equipment, including safety goggles. Disconnect hoses with extreme caution.

HIGH VOLTAGE ELECTRICITY INSIDE PANELS. RISK OF ELECTRICAL SHOCK. Disconnect power before servicing unit. Refer to the instruction manual.

TO REDUCE THE RISK OF FIRE, avoid the use of an extension cord because the extension cord may overheat. However, if you must use an extension cord, use No. 14 AWG at the minimum and as short as possible. Do not use this equipment in the vicinity of spilled or open containers of gasoline or other flammable substances.

Use this equipment in locations with mechanical ventilation that provides at least four air changes per hour or locate the equipment at least 18 inches above the floor.

Make certain that all safety devices are functioning properly before operating the unit. Before operating, read and follow the instructions and warnings in the manual.

CAUTION: SHOULD BE OPERATED BY QUALIFIED PERSONNEL. Operator must be familiar with air conditioning and refrigeration systems, refrigerants and the dangers of pressurized components.

Use only with R-12 (17700A/17701A) or R-134a (34700/34701). This equipment is not designed for any other purpose than recovering, recycling or recharging refrigerants! Do not mix refrigerant types!

ATTENTION!

Ce réservoir sous pression contient du frigorigène liquide. S'il est surchargé, ce réservoir peut exploser et causer des blessures ou la mort.

ATTENTION. Débrancher avant la maintenance.

ATTENTION. Pour réduire les risques d'incendie, ne pas utiliser de cordon prolongateur de section inférieure à 14 AWG de façon à éviter la surchauffe du cordon.

ATTENTION. Utiliser seulement du frigorigène R-12 (17700A/17701A) ou R-134a (34700/34701).

OPERATING NOTES

At temperatures exceeding 120°F / 49°C, wait 10 minutes between recovery jobs.

R-134a WARNINGS!

Use the Series 34700/34701 only with R-134a! Cross-contamination with other refrigerant types will cause severe damage to the A/C system and to service tools and equipment. Do not mix refrigerant types through a system or in the same container!

Avoid breathing A/C refrigerant and lubricant vapor or mist. Exposure may irritate eyes, nose and throat. To remove R-134a from the A/C system, use service equipment certified to meet the requirements of SAE-J2210 (R-134a recycling equipment). If accidental system discharge occurs, ventilate work area before resuming service.

HFC-134a service equipment or vehicle A/C systems should not be pressure tested or leak tested with compressed air. Some mixtures of air/HFC-134a have been shown to be combustible at elevated pressures. These mixtures are potentially dangerous and may result in fire or explosion causing injury or property damage.

Additional health and safety information may be obtained from refrigerant and lubricant manufacturers.

CONVERSION TABLE

OZ.	LBS.
0.5	0.03
1.0	0.06
1.5	0.09
2.0	0.13
2.5	0.16
3.0	0.19
3.5	0.22
4.0	0.25
4.5	0.28
5.0	0.31
5.5	0.34
6.0	0.38
6.5	0.41
7.0	0.44
7.5	0.47
8.0	0.50
8.5	0.53
9.0	0.56
9.5	0.59
10.0	0.63
10.5	0.69
11.0	0.69
11.5	0.72
12.0	0.75
12.5	0.78
13.0	0.81
13.5	0.84
14.0	0.88
14.5	0.91
15.0	0.94
15.5	0.97
16.0	1 lb.

Call toll-free



Technical Support Line
800-822-5561

in the continental U.S. or Canada.

In all other locations, contact your local distributor. To help us serve you better, please be prepared to provide the model number, serial number, and date of purchase.

To validate your warranty, you must complete the warranty card attached to your unit and return it within ten days from date of purchase.

• **NATIONWIDE NETWORK OF AUTHORIZED SERVICE CENTERS**

If your unit needs repairs or replacement parts, you should contact the service center in your area. For help in locating a service center, call the toll free technical support line.

Due to ongoing product improvements, we reserve the right to change design, specifications and materials without notice.

This equipment is designed to meet all applicable agency certifications including Underwriter's Laboratories, Inc., SAE Standards and CUL. Proper maintenance of this equipment will provide accurate A/C service for many years.

Certain state and local jurisdictions dictate that using this equipment to sell refrigerant by weight may not be permitted. We recommend charging for any A/C service by the job performed.

This weight scale provides a means of metering the amount of refrigerant needed for optimum A/C system performance as recommended by OEM manufacturers.

SPX **ROBINAIR**

*SPX Corporation
1224 Robinair Way
Montpelier, OH 43543-1952 USA
Phone 419-485-5561
Fax 419-485-8300*

Introduction	2
Glossary of Terms	2
Set Up Instructions	3
Selecting a Measurement Unit	4
Preparing the Vacuum Pump	5
Installing the Tank and Pulling a Vacuum	6
Adding Refrigerant to the Tank	8
Operating Guidelines	10
Using the Control Panel	10
Keypad Functions	11
Using the Digital Display	11
Operating Overview	14
Operating Instructions	16
Operating Tips	16
Recovering Refrigerant	17
Evacuating the A/C System	21
Replenishing A/C System Oil	23
Recharging the A/C System	24
Correcting an Incomplete Charge	26
Maintenance Instructions	27
Checking the Scale Accuracy	27
Calibrating the Scale	28
Calibrating the UL Circuit	29
Replacing the Filter-Drier	31
Changing the Vacuum Pump Oil	33
Checking for Leaks	34
Troubleshooting Tips	35
Using Manual Diagnostics	35
Recovery Operation	36
Recharging Operation	37
Error/Message Codes	38
Replacement Parts List	40
Flow Diagram	41
Wiring Diagram	42
Limited Warranty	43

U.S. Patents: 4,523,897; 4,688,388 Re 33,212; 4,768,347; 4,805,416; 4,809,520; 4,878,356; 4,938,031; 5,005,369; 5,005,375; 5,038,578; 5,042,271; 5,209,653; 5,248,125 Australian Patent: 613,058 Canadian Patents: 1,311,621; 1,311,622; 2,012,620; 2,026,348 European Patent: 0 315 296 B1 German Patent: 031296 Mexican Patent: 16208 OTHER U.S. AND FOREIGN PATENTS PENDING.

Mfd. by Robinair, SPX Corporation, Montpelier, OH 43543

This manual contains important safety procedures concerning the operation, use and maintenance of this product. Failure to follow the instructions contained in this manual may result in serious injury. If you are unable to understand any of the contents of this manual, please bring it to the attention of your supervisor. Do not operate this equipment unless you have read and understood the contents of this manual.

The Series 17700A/17701A is used for R-12 vehicles and the Series 34700/34701/34704 is used for R-134a vehicles. Both units operate the same and have the same features.

These units are UL-listed as single pass systems and meet the SAE specifications for recycled refrigerant. They're also designed to be compatible with existing service equipment and standard service procedures.

These units are simple to operate and have many user-friendly features:

- a hose holder rack for the manifold hoses
- large diameter wheels that make it easy to move the unit
- a plastic shroud that is resistant to abrasions and chemicals

To validate your warranty, complete the warranty card attached to your unit and return it within ten days from date of purchase.

GLOSSARY OF TERMS

A/C System	The air conditioning system being serviced
Unit	The refrigerant recovery/recycling/recharging unit
Unit Tank	The refillable refrigerant tank designed specifically for this unit
Source Tank	A disposable tank of new refrigerant used to refill the unit tank

Set Up Instructions

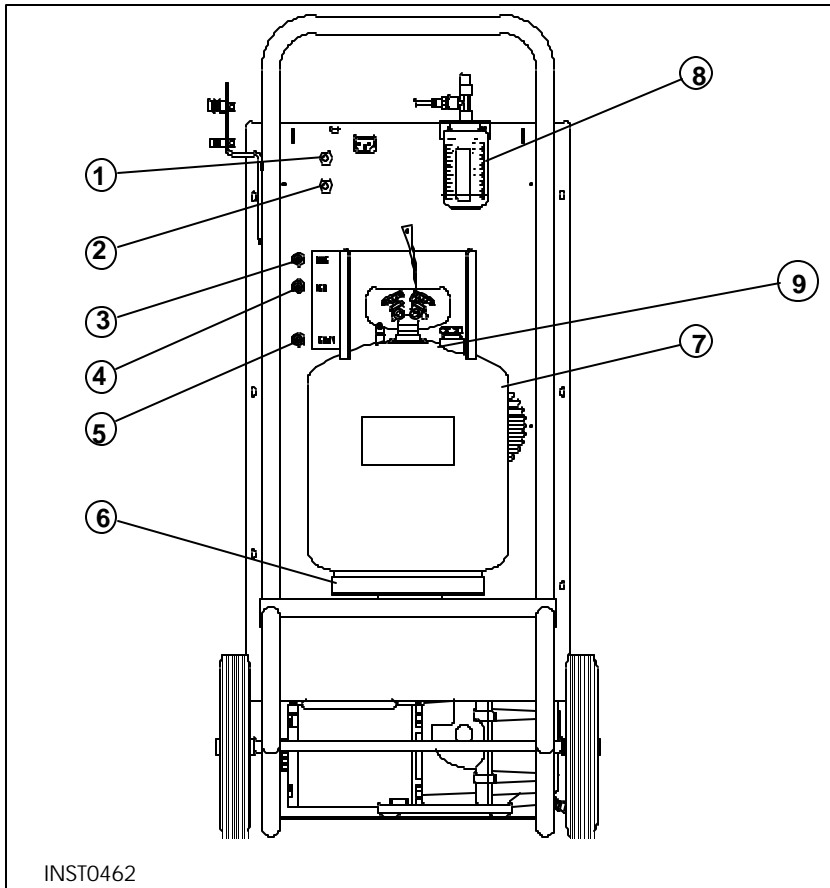

INST0462

Diagram of Unit's Components — External View

1. High Side Hose Port
2. Low Side Hose Port
3. Liquid Port
4. Vapor Port
5. Air Purge Port
6. Scale Platform
7. 50 lb. (23 Kg.) Unit Tank
8. Oil Injector
9. Tank Strap

Diagram of Unit's Components — Internal View

1. Relays
2. Compressor
3. Vacuum Pump
4. Filter
5. Manifold Block
6. Air Purge Assembly
7. Low Side Hose
8. High Side Hose
9. Hose Holders
10. Quick-Couplers (34700/34701 Only)

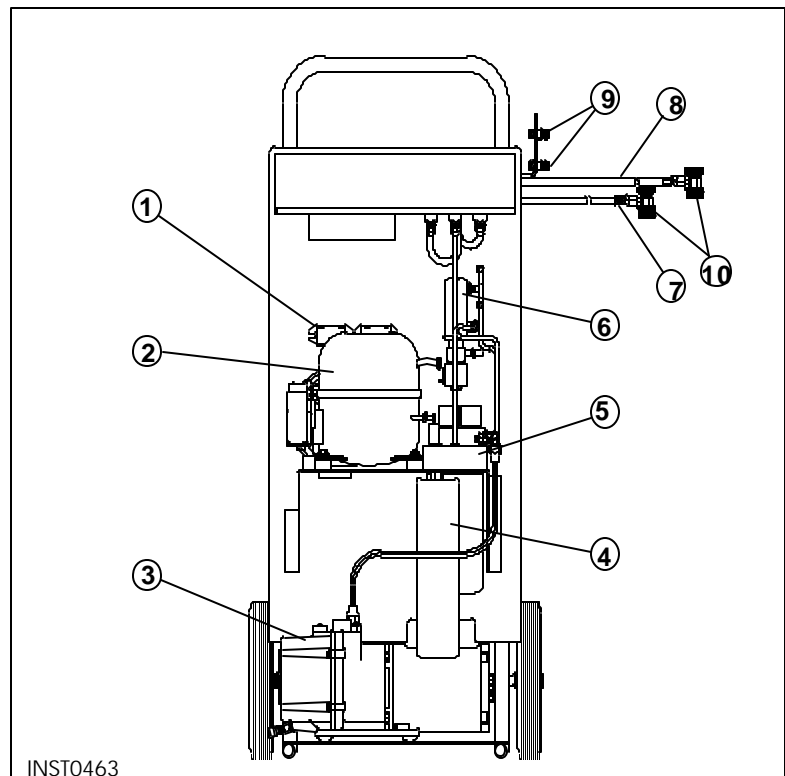

INST0463

Set Up Instructions

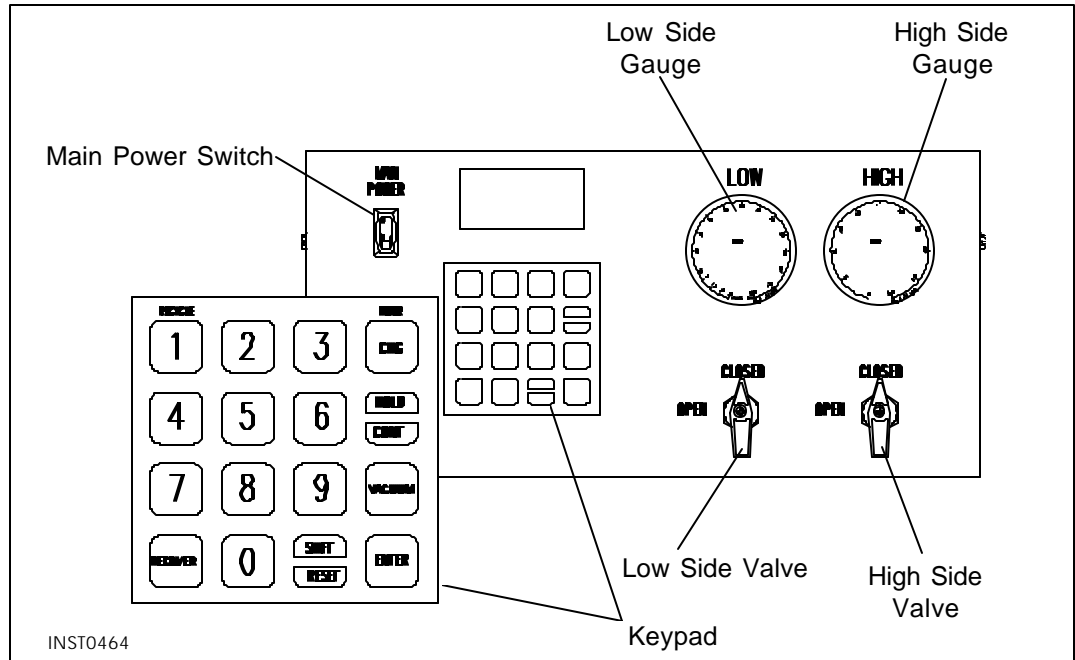

SELECTING A MEASUREMENT UNIT

The first step in setting up your unit is to select the unit of measure (either pounds or kilograms) to be used when operating the unit.

1. Plug in the unit to the appropriate power outlet and turn ON. Press **SHIFT/RESET** and **ENTER** at the same time. The display will be blank.
2. Press **0**. The display will indicate the current unit of measure.
3. Pressing **ENTER** will alternate between "LBS" and "KG". When the desired unit appears, press **SHIFT/RESET**.

PREPARING THE VACUUM PUMP

The VacuMaster® vacuum pump is shipped without oil in the reservoir. Before starting the unit, you must fill the pump with oil. Two 16-ounce (472 milliliter) bottles of oil are included with your unit.

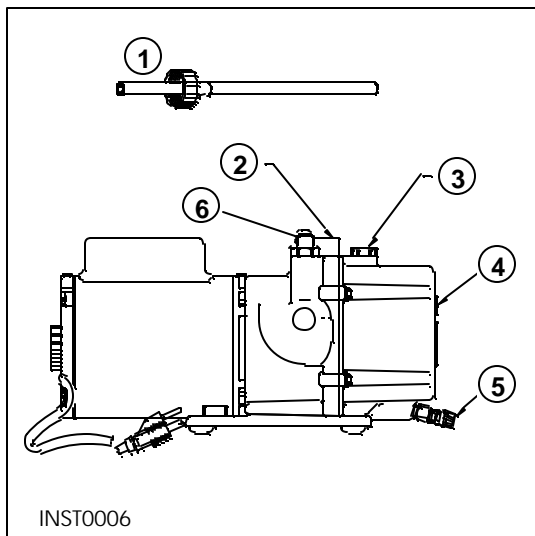

Diagram of Vacuum Pump Components

1. Oil Filler Tube
2. Pump Exhaust
3. Oil Fill Port
4. Sight Glass
5. Oil Drain Fitting
6. Inlet

IMPORTANT!
For maximum performance, be sure to change the vacuum pump oil frequently.

1. Remove the access door from the front of the unit.
2. Remove the black plastic plug on the oil fill port.
3. Attach the flexible hose and cap to the oil bottle to make it easier to fill the pump.
4. Pour approximately 13 ounces (384 milliliters) of vacuum pump oil into the oil fill port until oil just appears in the bottom of the sight glass on the reservoir.
5. Close both manifold valves on the control panel.

CAUTION! Avoid the use of an extension cord because the extension cord may overheat. However, if you must use an extension cord, use a No. 14 AWG minimum and keep the cord as short as possible.

6. Plug the unit into the proper voltage outlet, and turn on the unit's MAIN POWER switch.
7. Press **SHIFT/RESET** and **ENTER** at the same time to access the manual diagnostic mode.
8. Press **1** to start the pump.

Set Up Instructions

9. While the pump is running, add enough vacuum pump oil so that the oil level is even with the line on the reservoir's sight glass.
10. Press **1** or **SHIFT/RESET** to stop the pump.
11. Replace the black plastic plug on the oil fill port.
12. Replace the access door on the front of the unit.

IMPORTANT!
Be sure the pump is running when adding oil.

See "Maintenance Instructions" for step-by-step procedures for changing the vacuum pump oil.

INSTALLING THE TANK AND PULLING A VACUUM



WARNING



Always wear safety goggles when working with refrigerant. Use only authorized refillable refrigerant tanks. Read and follow all warnings at the beginning of this manual before operating the unit.

CAUTION! R-134a systems have special fittings (per SAE specifications) to avoid cross-contamination with R-12 systems. Do not attempt to adapt your unit for another refrigerant — system failure will result!

1. A new tank comes with a dry nitrogen charge of 10 to 15 psi to keep it clean and dry during shipment. Purge its nitrogen charge by opening either valve on the tank. Vent the pressure to the atmosphere, then close the valve.
2. Place the unit tank on the scale platform on the back of the unit. Securely tighten the thumbscrew on the platform to hold the tank in place. Attach the clip of the tank strap to the tank handle.
3. Connect the Quick Seal™ end of the yellow hose to the air purge port on the tank. Connect the open end of the yellow hose to the port on the unit marked **YELLOW**.
4. 34700/3470134704 Series — Attach the 16301 adapter (located on the oil drain) to the vapor valve of the tank. Attach the blue low side hose to the adapter. Open the coupler on the low side hose.
17700A/17701A Series — Attach the blue low side hose to the vapor valve of the tank.
5. Connect the open end of the 36" (91 cm) red vapor hose to the **RED** port on the back of the unit.

6. Connect the Quick Seal™ end of the 36" (91 cm) blue liquid hose to the blue LIQUID valve on the tank. Attach the other end of the hose to the BLUE port on the back of the unit.

CAUTION! Some tanks have slightly different valve configurations. Be sure to connect the RED hose to the GAS (vapor) valve and connect the BLUE hose to the LIQUID valve.

Before adding refrigerant, you must pull a vacuum on both the unit and the tank for five minutes to remove any air.

7. Open both valves on the tank.
8. Open the low side manifold valve on the control panel.
9. Press **SHIFT/RESET** and **ENTER** at the same time.
10. Press **1**. The vacuum pump starts and runs continuously until you press any other key.
11. Run the pump for a minimum of five minutes, then press "1" to stop the pump.
12. Press **SHIFT/RESET** again to return to the regular display mode.
13. Close the vapor valve on the tank.
14. Disconnect blue low side hose from the vapor port on the tank. Remove adapter and replace on the oil drain for storage. Connect the RED hose to the vapor valve on the tank.

ADDING REFRIGERANT TO THE TANK

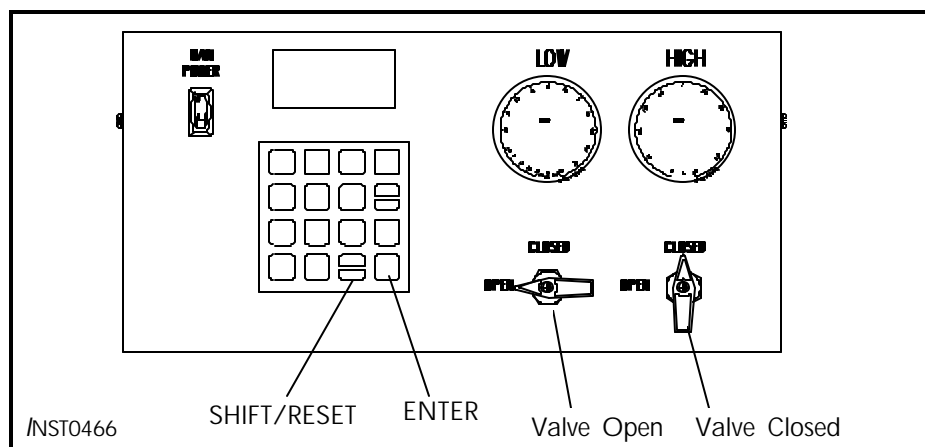

Diagram of Control Panel

Set Up Instructions

IMPORTANT!
The 96" (244 cm) red high side hose and the 96" (244 cm) blue low side hose are not used when adding refrigerant to the tank.

IMPORTANT!
On the 17700A/17701A Series, be sure to connect the 6" (15.2 cm) yellow adapter to the source tank **BEFORE** step 2.



WARNING



R-134a systems have special fittings (per SAE specifications) to avoid cross-contamination with R-12 systems. Do not attempt to adapt your unit for another refrigerant — system failure will result! Read and follow all warnings given at the beginning of this manual.

On the 34700/34701, be sure to only purchase tanks of R-134a refrigerant that use ½" (1.2 cm) Acme threads.

1. Close the blue LIQUID valve on the unit tank, and disconnect the 36" (91 cm) blue liquid hose from the valve.
2. 17700A/17701A Series — Connect the 6" (15.2 cm) yellow adapter to the source tank. Attach the 36" (91 cm) blue LIQUID hose to the yellow adapter.
34700/34701 Series — Connect the 36" (91 cm) blue LIQUID hose to the blue LIQUID valve of the source tank. Disposable tanks have only one valve and most must be turned upside down to transfer liquid (as shown in the drawing).
3. Open the blue LIQUID valve on the source tank. There is only one valve on a non-refillable tank. If you are using a non-refillable tank, follow the instructions on the side of the tank to obtain a liquid supply.

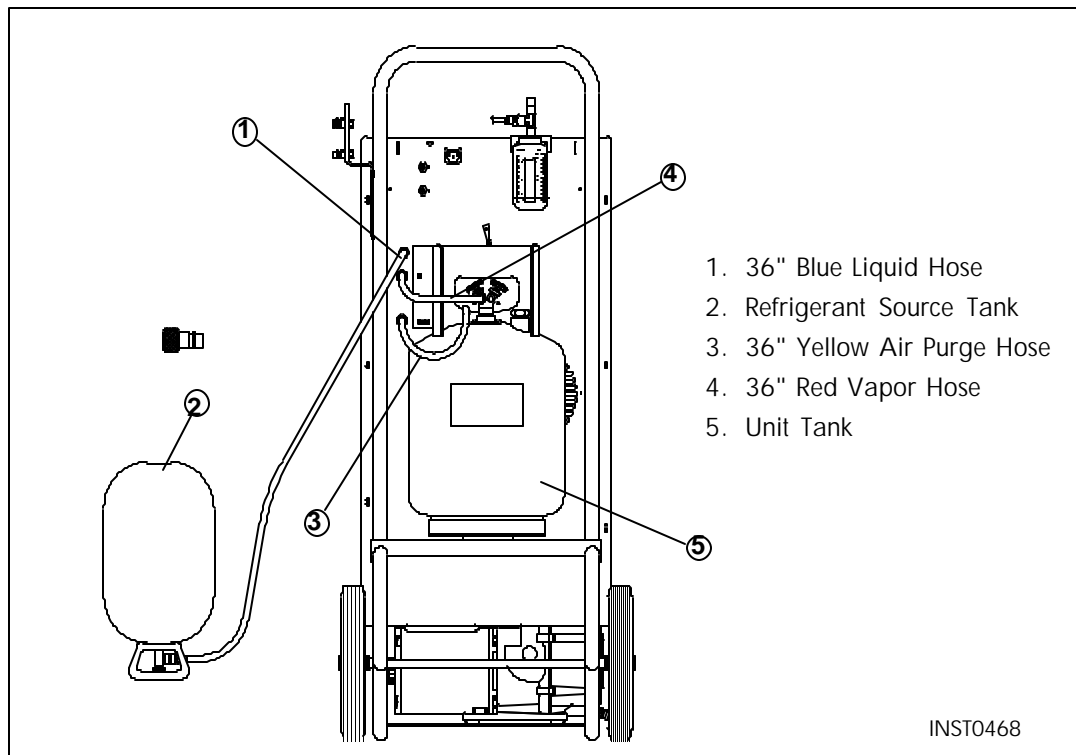

Diagram of Disposable Tank Connections When Adding Refrigerant

Set Up Instructions

CAUTION! Do not use the blue low side hose! The blue LIQUID hose is the blue hose attached to the tank's LIQUID valve.

4. Open the red GAS (vapor) valve on the unit tank.
5. Press **SHIFT/RESET** and **ENTER** at the same time to access the diagnostic mode.
6. Press **2** to begin transferring refrigerant. The display shows the "ADD" message for about two seconds, then shows the amount of refrigerant transferred.
7. Transfer stops automatically and the display shows the "CPL" message when the source tank is empty and has been pulled to 13 in. Hg. *or* the weight of refrigerant in the unit tank reaches 36 pounds (16 kilograms).

This process takes about 30 minutes. You can interrupt it at any time by pressing **HOLD/CONT** once. To resume the ADD procedure, press **HOLD/CONT** again.

The transfer of new refrigerant is limited by weight to leave space (about 10 pounds or 4.5 kilograms of refrigerant) in the unit tank for recovery purposes.

8. On the 17700A/17701A Series, close the supply valve on the source tank, and *carefully* disconnect the 36" (91 cm) blue liquid hose from the 6" (15.2 cm) yellow adapter, if used. Then remove the 6" (15.2 cm) yellow adapter from the source tank.

On the 34700/34701 Series, if you're using a disposable tank, turn it right side up, close its valve and *carefully* disconnect the 36" (91 cm) blue liquid hose.

9. Reconnect the 36" (91 cm) blue liquid hose from the back of the unit to the blue LIQUID valve on the unit tank, then open that tank's blue LIQUID valve.

Any non-condensable gases in the tank will be removed during the recycling sequence.

The unit is ready for use.

IMPORTANT!
On the 34700/
34701 Series,
source tanks of
R-134a must
have a 1/2"
ACME thread to
match the hose
fitting.

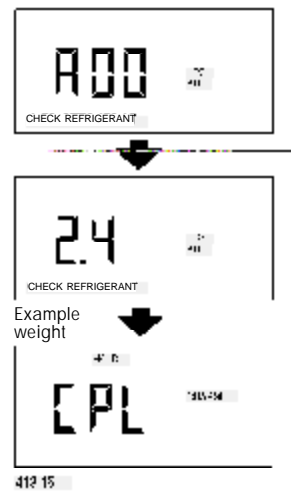

* Enter the correct weight for your application.

IMPORTANT!
Be sure to close both tank valves when the unit is not in use. Inspect the unit periodically for leaks. The manufacturer does not reimburse for lost refrigerant.

USING THE CONTROL PANEL

The control panel has various components that control specific operating functions.

MAIN POWER Switch — Supplies electrical power to the control panel.

Beeper — Emits an audible tone to alert you to unit operating functions. The beeper is located on the underside of the control panel below the keypad.

Digital Display — Shows the time programmed for vacuum and the weight of refrigerant programmed for recharging. Detailed instructions for programming the digital display follow this section.

LOW Side Manifold Gauge — Connects to an A/C system and shows the system's low side pressure.

HIGH Side Manifold Gauge — Connects to an A/C system and shows the system's high side pressure.

LOW Side Valve — Controls the low side flow from the A/C system through the unit.

HIGH Side Valve — Controls the high side flow from the A/C system through the unit.

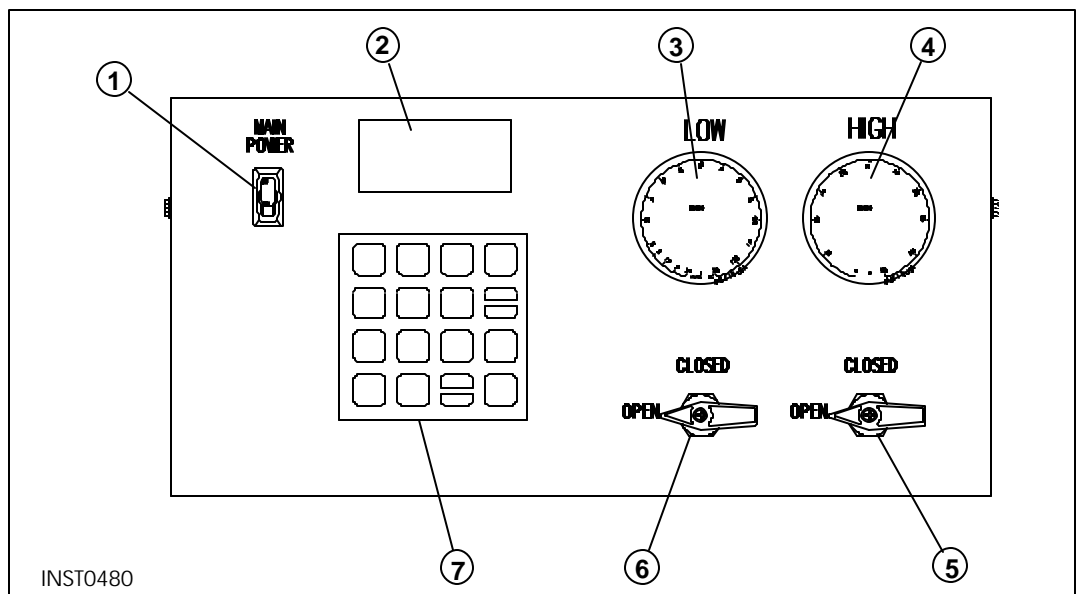

Diagram of Control Panel

- | | |
|----------------------|--------------------|
| 1. Main Power Switch | 5. High Side Valve |
| 2. Display | 6. Low Side Valve |
| 3. Low Side Gauge | 7. Keypad |
| 4. High Side Gauge | |

KEYPAD FUNCTIONS

In addition to the number keys, the keypad contains special keys that accomplish specific operating functions.

- **RECYCLE**—Activates the recycling sequence.
- **RECOVER**—Activates the recovery sequence.
- **SHIFT/RESET**—Activates “shifted” positions of keys on the keypad and resets the program mode.
- **FILTER**—Automatically recovers and evacuates to 17 in. Hg from the filter and low side of the unit.
- **CHG**—Automatically charges the A/C system with the programmed amount of refrigerant.
- **HOLD/CONT**—Interrupts the automatic cycle (HOLD), then resumes functions (CONT). Press once for HOLD, and again for CONT (continue).
- **VACUUM**—Activates the vacuum and automatic recycling sequence.
- **ENTER**—Enters programmed data into the unit’s memory.

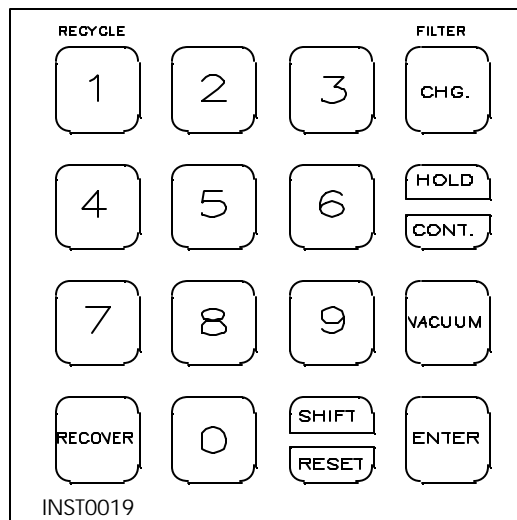

Diagram of Keypad

USING THE DIGITAL DISPLAY

This section explains the messages shown on the digital display, which is illustrated here for your convenience.

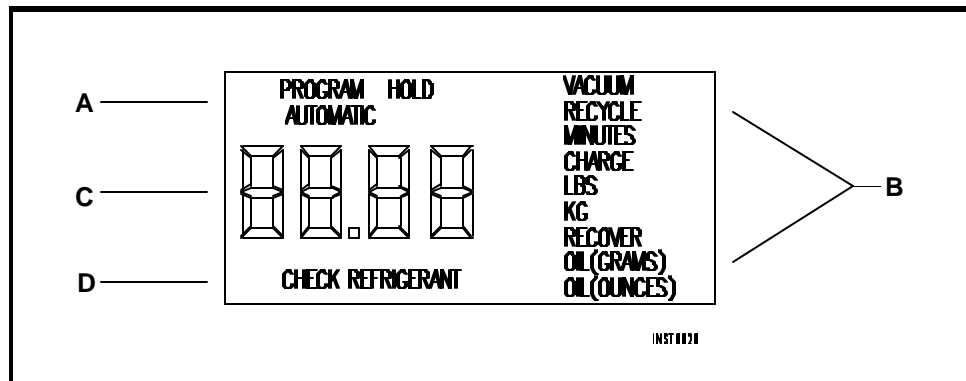

Diagram of Digital Display

Segment A — Indicates in which mode the unit is operating:

PROGRAM — The unit is in the programming mode, which allows you to program vacuum time and refrigerant weight **or** to review the existing program.

HOLD — This mode is used to change a refrigerant tank or to interrupt the vacuum/charging/recovery cycles.

AUTOMATIC — Indicates that the unit is running in a given cycle and will automatically stop when the cycle is complete.

Segment B — Indicates that the unit is either evacuating the A/C system **or** recovering, recycling or recharging refrigerant **or** that the unit is ready to be programmed for one of these functions:

VACUUM

- With **PROGRAM**, indicates that the unit is ready to be programmed for vacuum.
- With **AUTOMATIC**, indicates that the vacuum pump is running; the number displayed counts down in minutes and seconds, showing the amount of time remaining.
- With **HOLD**, indicates that **HOLD/CONT** was pressed to interrupt the vacuum cycle.

RECYCLE

- With **AUTOMATIC**, indicates the unit is recycling refrigerant from the tank.

CHARGE

- With **PROGRAM**, indicates that the unit is ready to be programmed for the amount of refrigerant to be charged into the A/C system; on the keypad enter the charge in pounds and hundredths of a pound or kilograms, depending on the measurement mode selected.
- With **AUTOMATIC**, indicates the unit is charging refrigerant into the A/C system; the number shown on the digital display counts down, showing the remaining amount of refrigerant to be dispensed.
- With **HOLD**, indicates that **HOLD/CONT** was pressed to interrupt the charging cycle; the number shown on the digital display is the amount of refrigerant remaining to be charged into the A/C system; to continue charging, press **HOLD/CONT** again.

RECOVER

- With **AUTOMATIC**, indicates the unit is recovering refrigerant from the A/C system and shows the amount of refrigerant recovered in pounds or kilograms, depending on the measurement mode selected.

OIL (OUNCES) or OIL (GRAMS)

- Lights up as a reminder to drain the oil separator after each job.

Use this chart as a quick reference for interpreting Segment B messages.

VACUUM	+	PROGRAM	=	Program unit for vacuum
VACUUM	+	AUTOMATIC	=	Vacuum pump is running
VACUUM	+	HOLD	=	Interrupted vacuum cycle
RECYCLE	+	AUTOMATIC	=	Unit is recycling refrigerant
CHARGE	+	PROGRAM	=	Program unit for charge
CHARGE	+	AUTOMATIC	=	Unit is charging A/C system
CHARGE	+	HOLD	=	Interrupted charging cycle
RECOVER	+	AUTOMATIC	=	Unit is recovering refrigerant

Quick Reference Chart for Segment B

Segment C — Shows a number or a coded error message on the digital display that indicates the unit's operating status or any specific problems. See **TROUBLESHOOTING TIPS** for a list of error codes and messages and their descriptions.

Segment D — Indicates that refrigerant is low — approximately six pounds (or 2.7 kilograms) of refrigerant is left in the tank. Either replace the tank or add refrigerant following the instructions in **ADDING REFRIGERANT TO THE TANK**.

This overview is designed as a quick reference when using your Enviro-Charge unit. Read and follow all warnings in the manual.

RECOVERY

1. Connect hoses to vehicle: red to high side port, blue to low side port.

17700A/17701A Series — Connect the red and yellow adapters to the vehicle ports first, then connect hoses.

34700/34701 Series — Open the quick coupler valves after they are connected.

2. Check the manifold gauges. There must be pressure to recover refrigerant.
3. Open both manifold valves.
4. Open both tank valves.
5. Plug in the electric cord, then turn on the **MAIN POWER** switch.
6. Press **RECOVER**.

- Unit will clear itself of refrigerant and automatically start recovery.

- Unit is in **RECOVER** mode of the AUTOMATIC cycle. The weight of refrigerant is displayed as it is recovered.

- Unit automatically shuts off and recovery is complete.

- Unit displays approximate amount recovered.

7. Wait five (5) minutes; watch the gauges. If there is no rise in pressure, recovery is complete. If a rise in pressure occurs, press **HOLD/CONT** and repeat until pressure holds for two (2) minutes.
8. Drain the oil separator and measure and record the amount of oil drained - it must be replaced with new oil during charging.

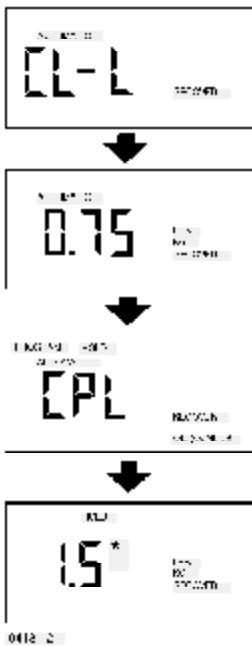

EVACUATION

1. Both manifold valves and both tank valves should still be open.
2. Press **SHIFT/RESET** until the message "PROGRAM VACUUM MINUTES" appears on the display.
3. Press **VACUUM** - The display counts down the vacuum time. Recycling begins automatically while the system is evacuated.
4. The unit displays **CPL** when evacuation is complete.
5. Add oil to the A/C system using the oil injector.
6. Press **SHIFT/RESET** to move to the recharging function.

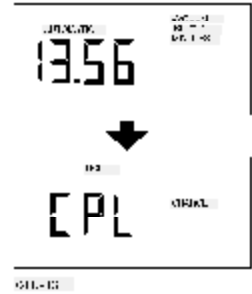

RECHARGING

Follow the manufacturer's recommendation for charging.

1. Be sure the appropriate manifold valves are open.
2. Be sure both tank valves are open.
3. Enter the refrigerant charge by weight in hundredths of a pound/kilogram.
4. Press **ENTER**.
5. Press **CHG**.
6. The display counts down to 0, then shows CPL when complete.
7. Close both manifold valves and start the vehicle. Set the vehicle's A/C system for maximum cooling. Check the gauges and the temperature in the vehicle.
8. Turn off the engine.
9. Disconnect the high side hose (close the 34700/34701/34704 coupler valves first) and start the vehicle. Open both manifold valves to pull refrigerant from the hoses.
10. At the lowest recommended operating pressure, close the low side valve and turn off the vehicle. On the 34700/34701/34704, close the low side valve and disconnect the low side hose. On the 17700A/17701A, disconnect the low side hose and remove the adapters.
11. Close both manifold valves and turn off the **MAIN POWER** switch.

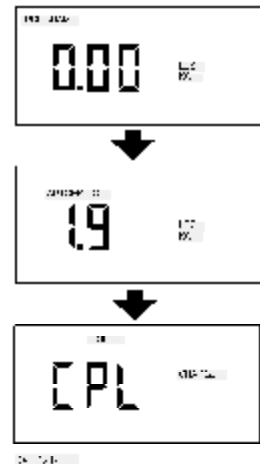

OPERATING TIPS

Follow the SAE-J1991 recommended service procedure for the containment of R-12 and the SAE-J2210 recommended service procedure for the containment of R-134a.

The recovery compressor is *not* a vacuum pump. The compressor pulls the A/C system to a partial vacuum only. You must use the unit's vacuum cycle to remove moisture from the A/C system. We recommend a minimum 15-minute vacuum with more time as required by the system manufacturer.

This unit is designed to be used with the manifold gauge set built into the control panel.

It includes a 6 cfm (142 l/m) VacuMaster® high vacuum pump for fast, thorough evacuation. Be sure to change the vacuum pump oil when the "OIL" message appears on the display.

R-134a systems require special oils in place of the mineral oil used with R-12 systems. Refer to the A/C system manufacturer's service manuals for oil specifications.

RECOVERING REFRIGERANT

WARNING

Some R-12 automotive fuel systems use a ¼" male SAE flare access fitting. Connecting your air conditioning service or recovery/recycling equipment to this fitting can result in cross-contamination of either the fuel system or the air conditioning service equipment. These conditions can be potentially dangerous due to the flammable characteristics of gasoline. Always refer to your vehicle manual prior to connection.

CAUTION! R-134a systems have special fittings (per SAE specifications) to avoid cross-contamination with R-12 systems. Do not attempt to adapt your unit for another refrigerant — system failure will result! Read and follow all warnings at the beginning of this manual before operating the unit.

Before beginning recovery, be sure your unit is set up as shown. Also be sure there is refrigerant in the tank and vacuum pump oil in the vacuum pump. See "Set Up Instructions."

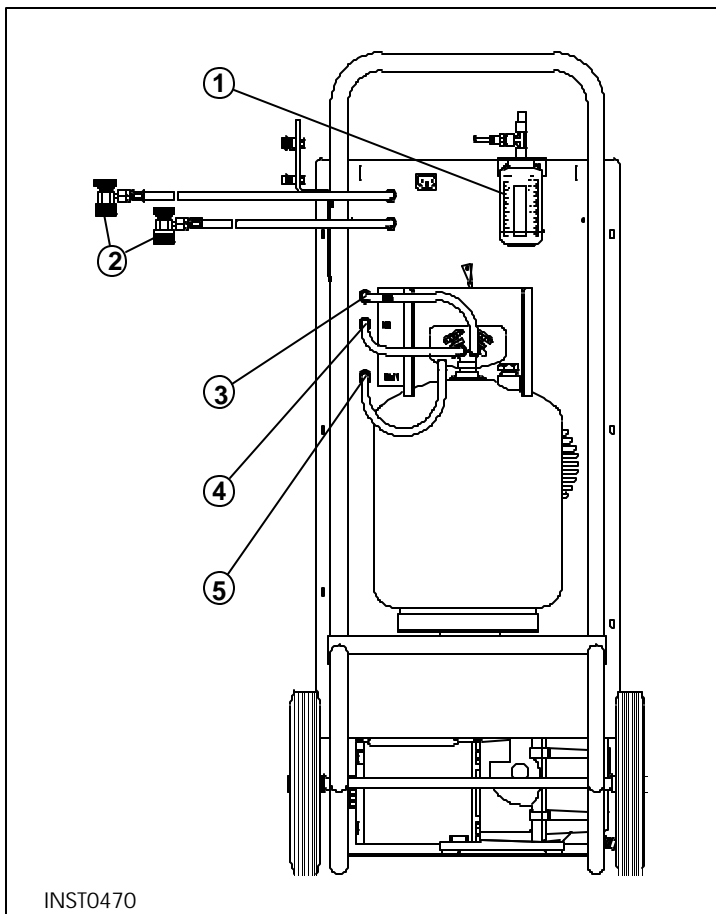

Diagram of Hose Connections

1. Oil Injector
2. Quick-Couplers (34700/34701 Series)
3. Blue Liquid Hose
4. Red Vapor Hose
5. Yellow Air Purge Hose

Note:

High and low side hoses on the 34700/34701 Series with Quick-Couplers are shown. The 17700A/17701A Series have SAE fittings.

INST0470

Operating Instructions

IMPORTANT!
Run the A/C system for a few minutes before starting the recovery process. Tests show more refrigerant is recovered if this action is taken. Turn the system off before proceeding.

1. Connect the hoses to the vehicle as follows:

17700A/17701A Series —

- Attach the proper adapters to the low side and high side fittings on the vehicle. (An adapter package comes with each unit.)
- Connect the unit's 96" (244 cm) red high side hose to the adapter attached to the vehicle's high side fitting.
- Connect the unit's 96" (244 cm) blue low side hose to the adapter attached to the vehicle's low side fitting.

34700/34701/34704 Series —

- Connect the unit's 96" (244 cm) red high side hose with the Quick-Coupler to the high side fitting of the A/C system, then open the coupler valve.
- Connect the unit's 96" (244 cm) blue low side hose with the Quick-Coupler to the low side fitting of the A/C system, then open the coupler valve.

2. Check the manifold gauges on the unit's control panel — they should both register above zero. If there is no system pressure, there is no refrigerant in the system to recover or the hoses are not connected properly.
3. Be sure the oil drain valve is closed.
4. Open both manifold valves on the control panel.

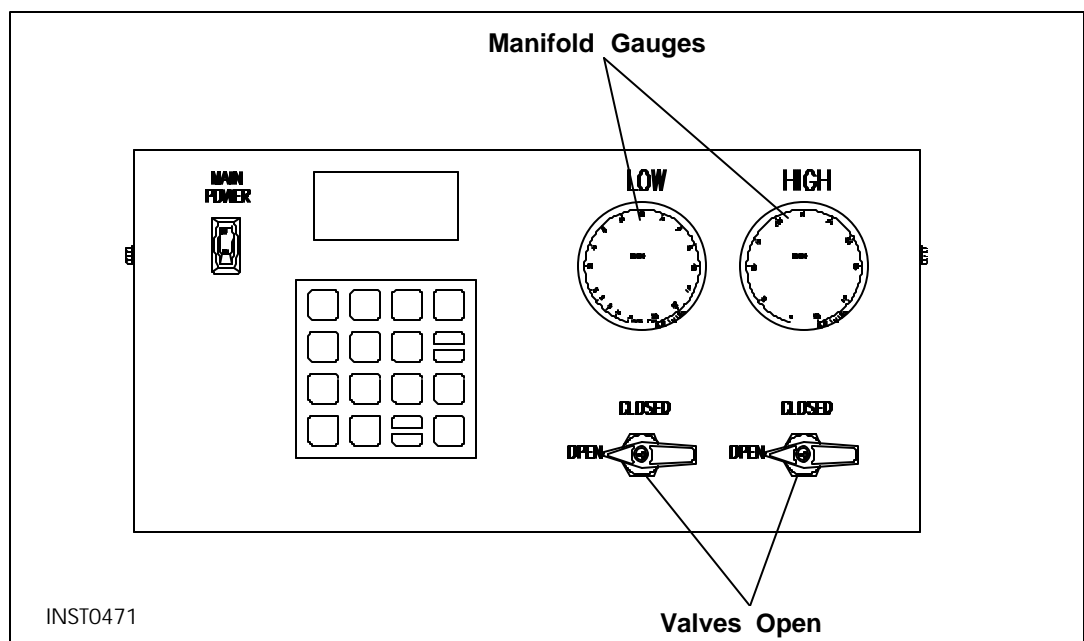

Diagram of Control Panel

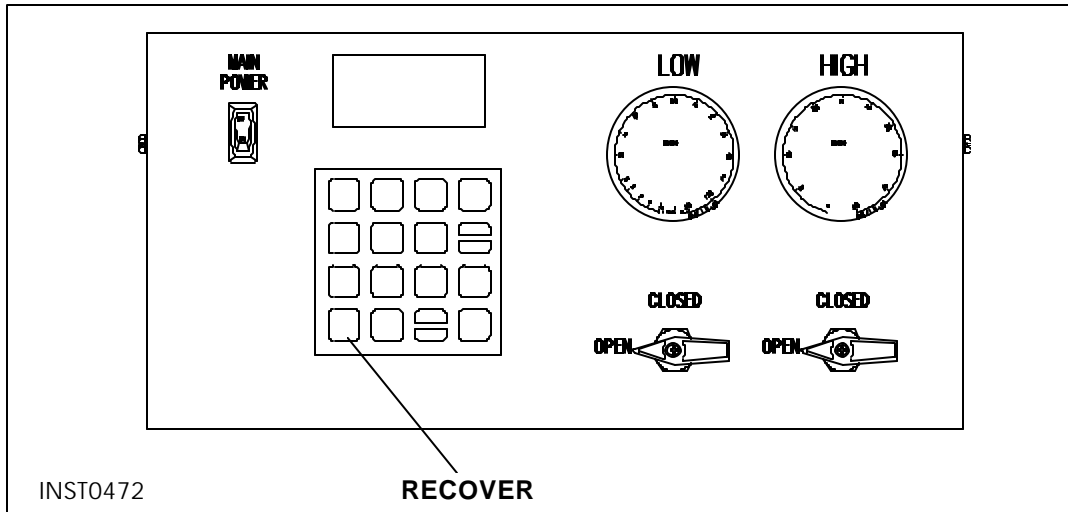
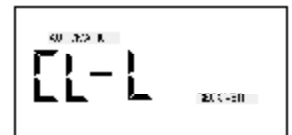

Diagram of Control Panel

5. Open the GAS (vapor) valve and the LIQUID valve on the tank.
6. Connect the power cord to the back of the unit and plug the cord into the proper voltage outlet. Turn on the **MAIN POWER** switch.
7. Press **RECOVER**.

Before recovery begins, the unit clears itself of any refrigerant remaining in the various components. You'll know this is occurring because the compressor will start and the "CL-L" message will display. This process takes up to 4 minutes to complete. Once the clearing is complete, the unit automatically begins to recover refrigerant from the system.



CAUTION! If the A/C system pressure is 25 psi or less, the message "CH-P" appears on the display to alert you not to attempt recovery from an empty system. Do *not* press HOLD/CONT to continue the recovery process unless you know the A/C system contains refrigerant.

The display shows that the unit is in the RECOVER mode and the AUTOMATIC cycle. You can monitor the amount of refrigerant removed from the system by watching the display. The compressor shuts off automatically when recovery is complete (at approximately 13 in. Hg). The display shows the "CPL" message and then alternately flashes the weight of refrigerant recovered and the "OIL (OUNCES)/OIL (GRAMS)" message.

8. To assure complete recovery of refrigerant, wait for 5 minutes and watch the manifold gauges for a rise in pressure above "0." If a rise occurs, press **HOLD/CONT**. Repeat as needed until the system pressure holds for 2 minutes.

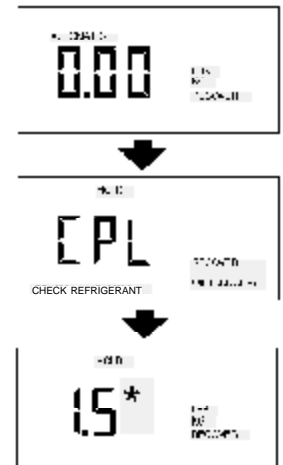

413 12

Operating Instructions

CAUTION! Drain the oil separator after each recovery. The display will indicate "OIL (OUNCES)" or "OIL (GRAMS)" as a reminder.

9. Be sure the oil catch bottle is empty, then *slowly* open the oil drain valve, and drain the oil into the oil catch bottle. This oil was removed from the A/C system during recovery. When all the recovered oil has completely drained, close the valve and record the amount of oil in the bottle.

Diagram of Oil Drain Valve and Bottle

1. Oil Drain Valve
2. Oil Catch Bottle

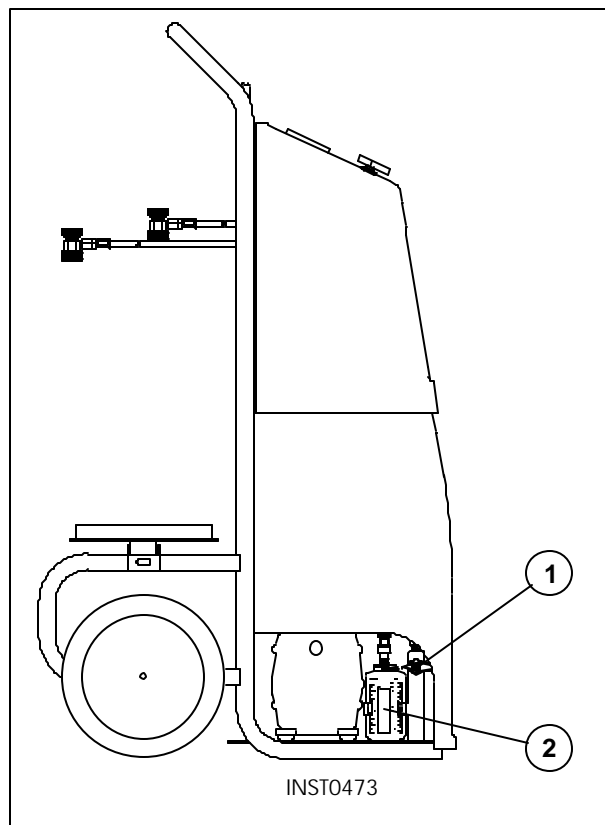

FULL

If the recovery tank fills completely:

- The compressor shuts off and the digital display shows the message "FULL."
- Change the tank.

The A/C system is now empty. Make any repairs at this time.

EVACUATING THE A/C SYSTEM

⚠ WARNING ⚠

Always wear safety goggles when working with refrigerant. Use only authorized refillable refrigerant tanks. Read and follow all warnings at the beginning of this manual before operating the unit.

This station is UL-certified as a single-pass unit. During evacuation, refrigerant is *automatically* recycled to assure recharging with the cleanest possible refrigerant in no additional time.

1. With the 96" (244 cm) high side and low side hoses connected to the A/C system, open both manifold valves on the control panel.
2. Open both the GAS (vapor) valve and the LIQUID valve on the tank.
3. To program the length of evacuation time, press **SHIFT/RESET** until the display shows that the unit is in the VACUUM mode.
4. For your convenience, a default vacuum time is preprogrammed to appear on the digital display at start-up. If the default time is correct, proceed to Step 5.

You can override this default setting by entering a different length of time in *both minutes and seconds*. Enter the required time by pressing the appropriate number keys, then press **ENTER**. The display shows the time in minutes.

5. Press **VACUUM** to start the vacuum pump. If the message "U-HI" appears, you have 25 psi or greater of pressure at the inlet. You must recover that pressure to continue. If necessary, press **RECOVER**.

The digital display counts down the remaining evacuation time in minutes and seconds. Recycling begins automatically five (5) seconds after the vacuum pump starts, and the "RECYCLE" message illuminates to indicate the unit is recycling refrigerant. Non-condensable gases (mostly air) are automatically vented from the tank during the recycling process, sometimes producing an audible pressure release (a hissing sound). This is a normal function.

6. The vacuum sequence continues for the programmed length of time, then displays the "CPL" message to indicate that evacuation is complete.
7. Pressing **SHIFT/RESET** at this point moves you to the charging process.

IMPORTANT!
You should evacuate for at least 15 minutes for adequate moisture and contaminant removal.



IMPORTANT!
If the vacuum pump has run for 10 or more hours without an oil change, the message "OIL" flashes on the display. Change the pump oil following the procedures in the MAINTENANCE INSTRUCTIONS.



Operating Instructions

Option A

You can *recycle refrigerant only* (without pulling a vacuum) for an indefinite period of time by pressing **SHIFT/RESET** and **RECYCLE** at the same time. To cancel this operation, again press **SHIFT/RESET**.

Option B

If you require *vacuum only*, press **SHIFT/RESET** and **ENTER** at the same time, then press **1**. Run the vacuum pump as long as required, then press **1** or **SHIFT/RESET** to cancel.

Option C

You can *automatically charge* refrigerant after the vacuum cycle:

1. Press **SHIFT/RESET** and **ENTER** at the same time. The display will be blank.
2. Press **4**, the display will show "AUTOMATIC", "VACUUM" and either "00" or "11." "00" indicates a disabled auto-charge and "11" indicates an enabled auto-charge.
3. Press **ENTER** to shift between enabled and disabled auto-charge. Press **SHIFT/RESET** to lock in mode choice to memory.

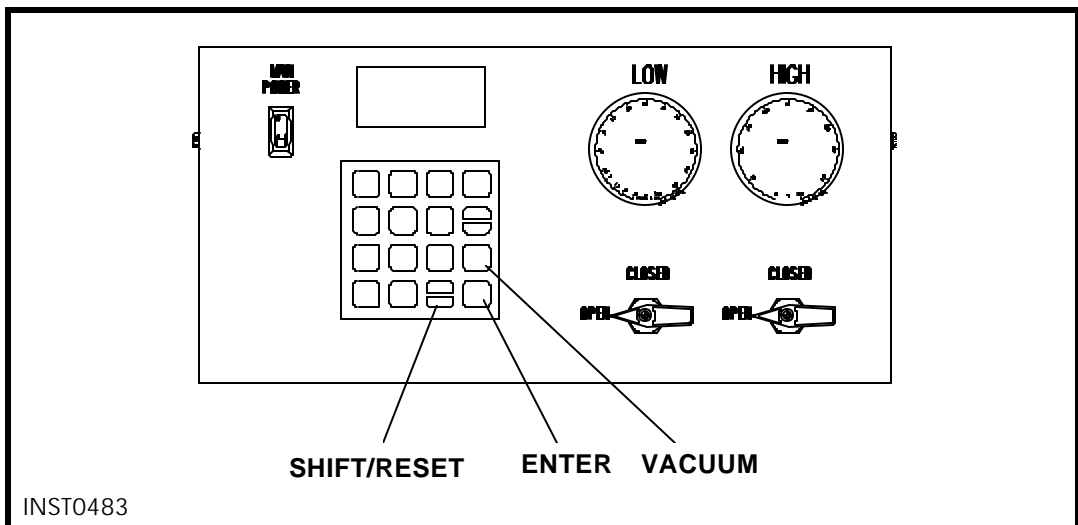

Diagram of Control Panel

REPLENISHING A/C SYSTEM OIL

Before charging the A/C system, you must replenish any oil removed from the A/C system during the recovery process.

1. Select the correct oil for the A/C system being serviced. Refer to the system manufacturer's service manual.

CAUTION! To prevent air from entering the A/C system, never let the oil level drop below the pick up tube while charging or replenishing.

2. Adjust the O-ring around the oil bottle to the required oil charge level. For example, if the bottle's oil level is at 4 ounces and you need only $\frac{1}{2}$ an ounce of oil to replenish the A/C system, place the O-ring at the $3\frac{1}{2}$ ounce level.
3. Install the bottle on the oil injection system on the back of the unit.

CAUTION! Never open the oil injection valve while there is positive pressure in the A/C system. This could blow oil back through the bottle vent.

4. Open the high side manifold valve.
5. Press the oil injection valve at the top of the bottle, and watch the level of oil being drawn into the A/C system.
6. Release the valve when the required oil charge has been pulled into the system.

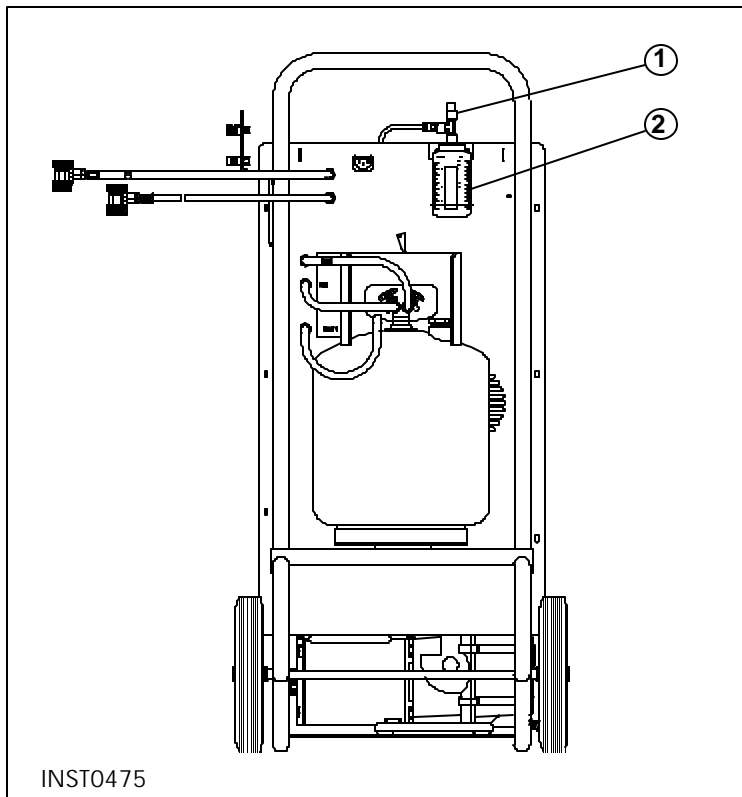

Diagram of Oil Injection System

1. Oil Injector Valve
2. Oil Injection Bottle

INST0475

Operating Instructions

IMPORTANT!
You can charge oil through either the low side or high side, or both, depending on the vehicle manufacturer's recommendation. Just open the appropriate manifold valve or valves.

IMPORTANT!
Do not place any weight (including your hands and feet) on the tank or scale during the refrigerant transfer process. Any weight disturbance will cause an incorrect transfer.

RECHARGING THE A/C SYSTEM



WARNING



Always wear safety goggles when working with refrigerant. Use only authorized refillable refrigerant tanks. Disconnect hoses with extreme caution!

All hoses may contain liquid refrigerant under pressure. Read and follow all warnings at the beginning of this manual before operating the unit.

CAUTION! To be sure the unit tank has sufficient refrigerant for recharging, press **SHIFT/RESET** once to access the program mode, then press **SHIFT/RESET** and **ENTER** at the same time to enter the diagnostic mode. Then press "6." The display must show 36 pounds (16 kilograms) or more because the empty weight of the tank is 28 pounds (13 kilograms) and about 8 pounds (four kilograms) of refrigerant is required to assure a complete A/C system charge. If the amount displayed is less than 36 pounds (16 kilograms), add new refrigerant to the tank following the instructions in **ADDING REFRIGERANT TO THE TANK**.

When you turn on the unit, you can enter the amount of refrigerant to be charged. The unit stores this value in memory until you turn it off or program a different amount.

1. Open the appropriate manifold valve(s) on the control panel.
2. Be sure both valves on the tank are open.
3. Enter the amount of refrigerant required to recharge the system by pressing the appropriate number keys. The charge must be entered in hundredths of a pound or kilogram — the same way the nameplate on the vehicle's A/C system specifies the charge.
4. Press **ENTER**.
5. Press **CHG** to begin the charging process. The digital display shows the "AUTOMATIC" message and the weight of refrigerant you've programmed for recharge. The charging solenoid opens to transfer refrigerant, the display counts down to zero, and the "CPL" message displays when charging is complete.
6. Close the manifold valve(s).

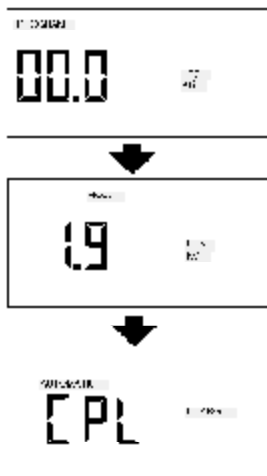

CAUTION! Be sure both manifold valves are closed before starting the A/C system.

WARNING

Before starting the vehicle's engine, check to see that it is in **PARK** or **NEUTRAL** with the emergency brake on. Never run a vehicle without adequate ventilation.

7. Start the vehicle's A/C system, and let it run until the gauge pressure readings stabilize (compare the gauge readings with the system manufacturer's specifications).
8. Check the evaporator outlet temperature to be sure that the A/C system is operating properly (refer to the system manufacturer's specifications for the proper temperature).
9. Turn off the vehicle's engine.

On the 17700A/17701A Series:

10. Disconnect the 96" (244 cm) red high side hose from the high side adapter.
11. Disconnect the 96" (244 cm) blue low side hose from the low side adapter.
12. Remove the adapters from the vehicle's A/C system by pushing down on the coupler while unscrewing the fitting.

On the 34700/34701/34704 Series:

10. Close the high side coupler valve, then disconnect the 96" (244 cm) red high side hose from the A/C system.
11. Restart the vehicle, then open both manifold valves on the control panel. Refrigerant from both hoses will be drawn quickly into the A/C system through the blue low side hose.
12. When both gauges show the lowest operating pressure recommended by the manufacturer, close the low side valve and turn off the vehicle's engine.

On Both Series:

13. Close the low side coupler valve and disconnect the 96" (244 cm) blue low side hose from the A/C system.
14. Close both manifold valves, and turn off the **MAIN POWER** switch.



IMPORTANT!
If the message "ADD" appears, there is not sufficient refrigerant in the tank. Follow the instructions in **ADDING REFRIGERANT TO THE TANK.**

IMPORTANT!
For maximum charging accuracy, you must clear the hoses of all refrigerant.

CORRECTING AN INCOMPLETE CHARGE

On rare occasions, you may find that the total charge does not transfer to the A/C system. There are two reasons why this can occur:

1. The refrigerant transfer is too slow because the pressure in the unit tank and in the A/C system is equal. When this happens, the unit emits an audible signal and the display shows the weight of refrigerant remaining to be transferred. To pull the remainder of the charge into the A/C system, you should:
 - Close the high side valve on the control panel.
 - Open the low side valve on the control panel.
 - Start the A/C system and press **HOLD/CONT**. The remaining charge is pulled into the system and the display shows the “CPL” message.
2. The transfer will not complete and the display shows the “CHECK REFRIGERANT” message because there is not enough refrigerant in the tank to complete the process. You must then recover the partial refrigerant charge in the A/C system, add refrigerant to the tank and complete another evacuation and charge procedure:
 - Press **HOLD/CONT** to interrupt the cycle.
 - Press **SHIFT/RESET** to reset the unit.
 - Recover the refrigerant that was charged into the A/C system, following the instructions in RECOVERING REFRIGERANT.
 - Add refrigerant to the tank, following the instructions in ADDING REFRIGERANT TO THE TANK.
 - Evacuate the A/C system, following the instructions in EVACUATING THE A/C SYSTEM.
 - Recharge the A/C system.

The vehicle now has a complete charge.

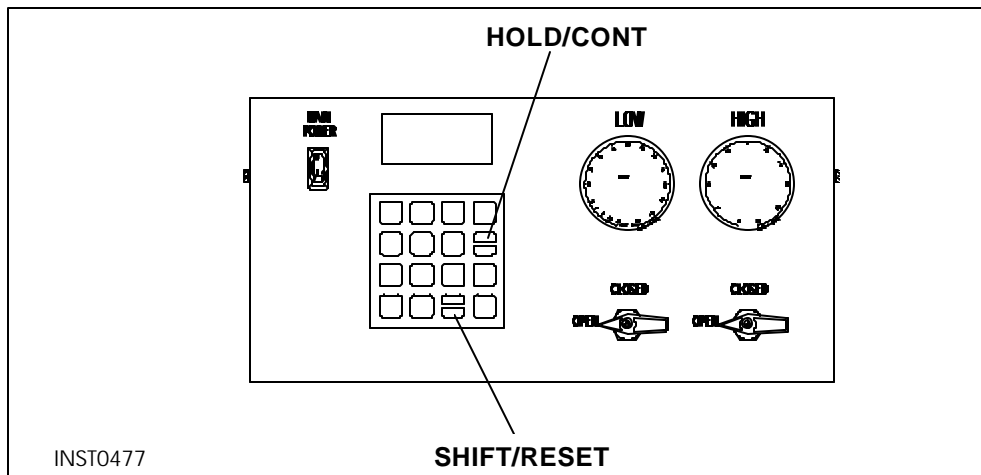

Diagram of Charging Connections

There are just a few routine maintenance procedures necessary to keep your unit operating properly.

CHECKING THE SCALE ACCURACY

To ensure continued charging accuracy, check your scale using these procedures every thirty (30) days or 100 service jobs, whichever comes first.

Also if the microprocessor senses that calibration has been lost, the "CAL" message displays. Follow this procedure to check the scale accuracy:

1. While in the PROGRAM mode, press **SHIFT/RESET** and **ENTER** at the same time to enter the diagnostic mode and clear the digital display.
2. Press **6** to display the approximate scale platform weight.
3. Remove the tank from the scale platform. The empty platform weight displayed should be zero. (± 2 pounds or ± 1 kilogram)
 - If the displayed weight is not within these limits, the CHECK REFRIGERANT message will also display. Call the manufacturer.
 - If the display does not show the correct weight with ± 1 lb., see "Calibrating the Scale " section.
4. If the calibration is correct, press **SHIFT/RESET** to exit.

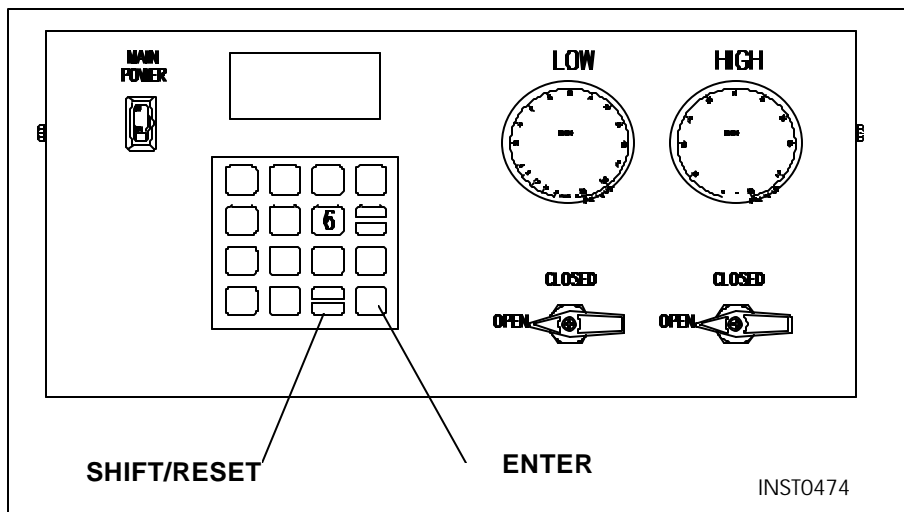

Diagram of Control Panel

CALIBRATING THE SCALE

IMPORTANT!

You must have a known exact weight of 40 lbs. \pm .01 (18.14 kg \pm .005)

1. Remove all weight from the scale platform.
2. Turn on the MAIN POWER switch.
3. Press **SHIFT/RESET** and **ENTER** at the same time.
4. Press **8-7-8-7**. The display will show "A-1."

NOTE: If you press any other key before the 8-7-8-7 sequence, you will not be able to enter the automatic calibration routine.

5. Press **0** and then **ENTER**. The display will show "0.00" and then change to the A-2" message.
6. Place a known exact weight of 10-60 lbs. on the center of the platform. Enter that weight on the display using the keypad, then press **ENTER**. The display will return to the vacuum mode.
7. Check the scale accuracy by pressing **SHIFT/RESET** and **ENTER** and the same time. When the diagnostics mode is entered (the display is blank) press **6**. The display shows the amount of weight on the scale platform, and 0.00 when it is removed.

CALIBRATING UL CIRCUIT



WARNING



Unplug the unit before beginning any service work. Improper use or connections can cause electrical shock. Only qualified personnel should perform service work.

If the scale assembly and UL circuit are not calibrated, the scale can overflow the tank, causing possible explosion and/or vehicle overcharge.

Live AC voltages are present in the unit when the power is turned on. Use caution when making the adjustments below.

The scale on the 700 series units will only handle a 50lb. tank. The UL circuit is a tank overflow protection device. The main board is programmed to display FULL at 73 lbs. (33.11 kg.) the UL circuit is set as a back up fail safe to the programming. Follow these steps to calibrate the circuit:

1. Remove all weight from the scale platform. Remove the shroud from the unit by removing (3) screws. Also, be sure to remove the oil bottle by loosening (2) screws.

2. Turn on the MAIN POWER switch.

NOTE: Press **0** to enter the pound or kilogram selection mode. Press **ENTER** to toggle between lb. or kg. Press **SHIFT/RESET** and **ENTER** to accept the displayed setting and exit mode.

3. Press **SHIFT/RESET** and **ENTER** at the same time.

4. Press **6** to display the absolute weight on the scale.

5. Place exactly 76 lbs. \pm .01 lbs. (34.5kg. \pm .005 kg.) on the scale and, with a small screwdriver, adjust the P1-POT* (Potentiometer) until the display just indicates HOLD.

6. Remove one pound from the scale and the HOLD segment should go off. Press **SHIFT/RESET** to return to normal operations.

UL CIRCUIT CALIBRATION (continued)

NOTE: Certified weights can be added to check positive response and then removed to check negative response.

7. Reassemble oil bottle and shoud back on the unit.
 8. While the circuit calibration is now finished, the scale must still be calibrated to complete the calibrating procedure.
- * The P-1 POT (Potentiometer) is located below the keypad at the front of the circuit board.

NOTE: This entire procedure must be completed to update the scale calibration memory of the unit. turning off the power at any time dureing the procedure returns the unit to the previous calibration values and the procedure must be started again from the beginning.

REPLACING THE FILTER-DRIER

The filter-drier on this unit is designed to trap acid and particulates and is formulated to remove water from the refrigerant. You must change the filter-drier to assure adequate moisture and contaminant removal.

Typically, you can recycle up to 300 pounds (136 kilograms) of R-134a or 600 pounds (272 kilograms) of R-12 between filter changes. To help you know when you've reached that point, the unit displays the "CH-F" warning message, prompting you to change the filter-drier.

Once the "CH-F" message displays, you can:

- *Bypass the filter replacement routine:*
Press **HOLD/CONT**, and resume operation to complete a procedure before changing the filter-drier.

CAUTION! For best results, use Robinair filter-driers (part no. 34724). All performance tests and claims are based on using this specially-blended filter-drier. Use of another may affect performance results.

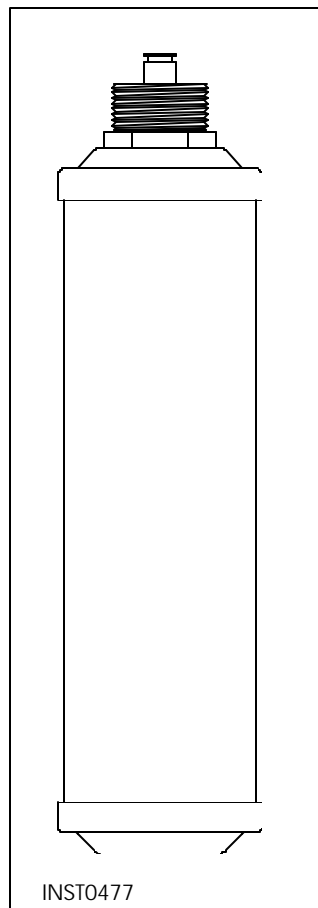

*Diagram of
Filter-Drier*

- *Start the filter changeout routine:*
 1. If they are open, close both manifold valves.
 2. Open the oil drain valve and make certain all oil has been drained, then close the valve. Remove oil drain bottle and dispose of used oil in accordance with all local and state regulations.
 3. Connect the blue low side hose to the oil drain port. Open the oil drain valve. On 34700/34700 Series, open the valve located at the end of the low side hose.
 4. Open the low side valve on the control panel.
 5. Press **SHIFT/RESET** and **FILTER** at the same time to recover all the remaining refrigerant from the low side of the unit. The display shows the messages "FIL," "AUTOMATIC" and "RECOVER." When all of the refrigerant has been removed, the messages change to "FIL" and "HOLD" to indicate the unit is waiting for the filter replacement.

Maintenance Instructions

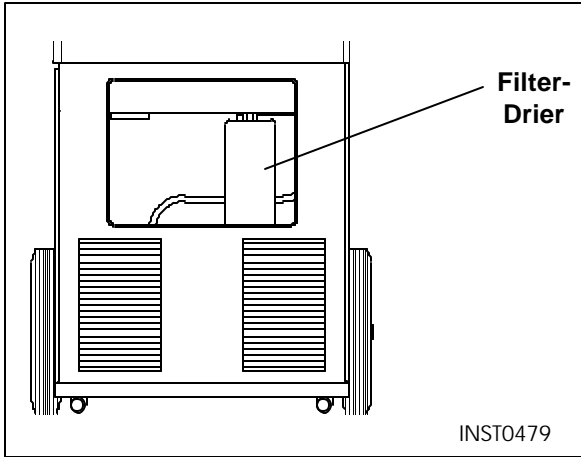

6. When all of the refrigerant has been recovered, remove the filter-drier by unscrewing it from the manifold block. Dispose of the used filter-drier properly.
7. Remove the cap from the filter-drier, then install the new filter-drier. Tighten to 120 in. lbs.
8. Press **HOLD/CONT.** The vacuum pump starts automatically and runs for five minutes before shutting off. The messages on the digital display change to "FIL" and "VACUUM."
9. After the vacuum pump shuts off, close the oil drain valve. Remove the low side hose from the oil drain port and reinstall the oil drain bottle.



NOTE: **34700/34701/34704 Series** units use special fittings at the ends of the charging hoses. **17700A/17701A Series** units use standard 1/4" SAE flare fittings.

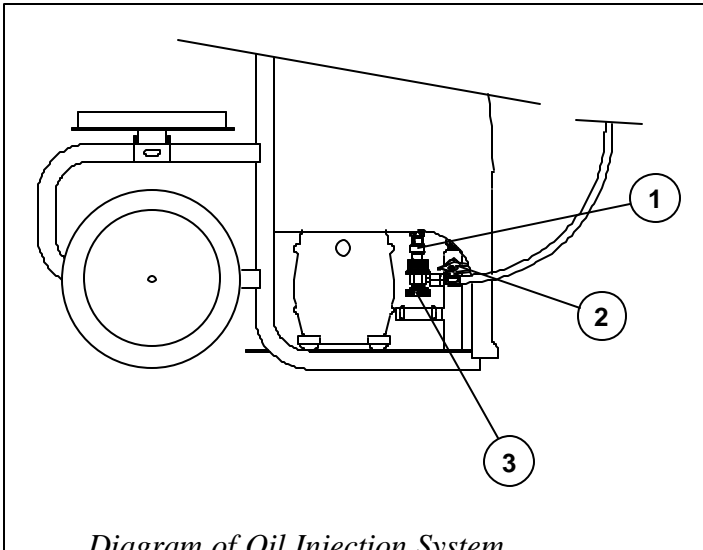

Diagram of Oil Injection System

1. Oil Drain Port
2. Oil Drain Valve
3. Low Side Hose Valve
(34700/34701/34704 Series Only)

CHANGING THE VACUUM PUMP OIL

For maximum vacuum pump performance, change the vacuum pump oil when the "OIL" message flashes on the display (the vacuum pump has run for more than 10 hours or more without an oil change).

1. Turn on the MAIN POWER switch. The display shows the messages "PROGRAM - VACUUM - MINUTES - 15:00."
2. Press **VACUUM**. The display shows the "OIL" message.
3. Press **SHIFT/RESET** and **ENTER** at the same time to reset the 10 hour timer.
4. Press **VACUUM** again, and let the vacuum pump run for 5 minutes.

NOTE: If the display indicates "OIL", press **SHIFT/RESET** and **ENTER** at the same time to reset the 10 hour timer.

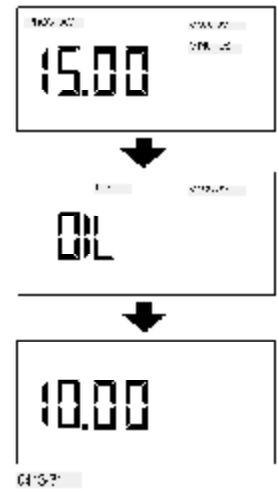

5. At the end of 5 minutes, press **HOLD**.
6. Remove the access door from the front of the unit.
7. Remove the black plastic plug on the oil fill port.
8. Remove the oil drain cap from the vacuum pump, then drain the contaminated oil into a suitable container and dispose of it properly.
9. Replace the oil drain cap.
10. Attach the flexible tube and cap to the oil bottle and pour 5 ounces of vacuum pump oil into the oil fill port.
11. Press **CONT**. While the pump is running, slowly add new vacuum pump oil until the oil level is even with the line on the reservoir's sight glass.
12. Replace the black plastic plug on the oil fill port.
13. Replace the access door on the front of the unit.
14. Press **VACUUM** to continue or turn the MAIN POWER switch to OFF.

Maintenance Instructions

Diagram of Vacuum Pump

1. Oil Filler Tube
2. Pump Exhaust
3. Oil Fill Port
4. Sight Glass
5. Oil Drain Fitting
6. Inlet

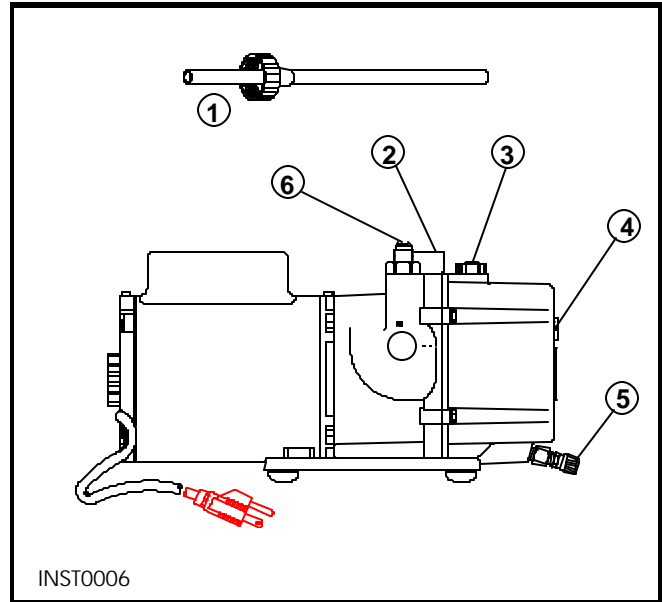

IMPORTANT!
Inspect the unit periodically for leaks. The manufacturer does not reimburse for lost refrigerant.

CHECKING FOR LEAKS

Every three months, or as specified by local or state laws, you should check your unit for leaks.

1. Turn off the MAIN POWER switch, and disconnect the power cord from the outlet.
2. Remove the shroud by removing the threaded screws at the back of the unit.
3. Use a leak detector to probe all fitting connections for refrigerant leaks. Tighten fittings if a leak is indicated.
4. Replace the shroud.

USING MANUAL DIAGNOSTICS



Be sure to discharge any system pressure before performing any manual diagnostics.

This unit's manual diagnostics mode is easily accessible through the keypad.

1. Press **SHIFT/RESET** and **ENTER** at the same time. The display should be blank except for the decimal point.

2. Press the following keys to perform these functions:

Press 1 — Starts the vacuum pump to begin evacuation. Press **1** again (or **SHIFT/RESET**) to turn off the pump.

Press 2 — Begins the transfer of refrigerant. The "ADD" message displays momentarily, then the display shows the amount of refrigerant transferred. Press **HOLD/CONT** at any time to interrupt the transfer and again to resume operation.

Press 3 — Displays the total amount of refrigerant recovered. Each time recovery is completed, that amount is added to the existing total. To clear the internal counter, press **SHIFT/RESET** and **ENTER** at the same time while the total is being displayed. The maximum amount recorded is 9,999 pounds (or 99 kilograms) of refrigerant.

Press 4 — Automatic charge after the vacuum cycle. The display will show "AUTOMATIC", "VACUUM," and either "00" or "11." "00" indicates a disabled auto-charge and "11" indicates an enabled auto-charge. Press **ENTER** to shift between enabled and disabled auto-charge. Press **SHIFT/RESET** to lock in mode choice to memory.

Press 5 — All display segments light up. Press **5** again to turn off.

Press 6 — Displays the approximate weight on the scale.
See CHECKING THE SCALE ACCURACY for diagnostic procedures.

Press 7 — Displays the weight of refrigerant contained in the tank.

3. Press **SHIFT/RESET** to return to the PROGRAM mode.

RECOVERY OPERATION

Compressor does not start or stops prematurely

Problem: Power cord not plugged in or no power at plug

Solution: Check circuit for power

Problem: MAIN POWER switch is off

Solution: Turn on switch

Problem: "FULL" message on digital display

Solution: Change tanks. See INSTALLING THE TANK

Problem: "HI-P" message on digital display

Solution: Be sure tank valves are open and hoses are properly connected to the tank, or

Check the scale calibration. See CHECKING THE SCALE ACCURACY

Problem: "CH-F" message on digital display

Solution: Remove and replace the filter-drier. See REPLACING THE FILTER-DRIER and be sure to pull a vacuum

Problem: Faulty components

Solution: Call service center

Runs a short time, but does not complete recovery

Problem: Tank valves closed

Solution: Open both valves and be sure hoses are properly connected to the tank

Problem: Manifold valves closed

Solution: Open both valves

Problem: Faulty components

Solution: Call service center

Runs but won't shut off

Problem: Oil drain valve open

Solution: Close the valve

Problem: Leak in vehicle system

Solution: Locate and repair all system leaks

Problem: Hoses are not properly connected to the vehicle

Solution: Check hose connections

Problem: Faulty components

Solution: Call service center

RECHARGING OPERATION

No power when Main Power switch is on—no display showing

Problem: Unit unplugged

Solution: Plug the unit into a power source

Problem: No power at wall outlet

Solution: Locate the problem with the outlet or change outlets

Audible tone sounds during refrigerant transfer

Problem: Transfer stopped or too slow

Solution: Start the A/C system and pull the remaining refrigerant into system. See RECHARGING THE A/C SYSTEM or
Be sure the blue hose has access to the tank

Problem: Refrigerant supply empty

Solution: Add refrigerant to the tank

Problem: Blue LIQUID tank valve closed

Solution: Open the blue LIQUID tank valve

Refrigerant does not flow

Problem: Refrigerant supply empty

Solution: Add refrigerant to the tank

Problem: Flow restriction

Solution: Check all connections on the A/C system (the 17700A/17701A should have adapters on both the low and high side fittings and the couplers on the 34700/34701 should be open), or
Check the blue hose connection at the tank's blue valve — be sure it is getting access, or
Check the tank's blue valve — it should be open, or
Be sure the A/C system has had a minimum of 15 minutes of vacuum

Vacuum pump runs, but low side gauge does not register an appropriate vacuum

Problem: Pump oil contaminated

Solution: Flush and change the vacuum pump oil

Problem: Charging line loose

Solution: Check connections

Problem: Manifold leaking

Solution: Check connections

Problem: Low side valve closed

Solution: Open low side valve

Problem: $\frac{3}{8}$ " hose improperly connected to pump

Solution: Check connections

ERROR/MESSAGE CODES

- ADD** There is less than six pounds (2.7 kilograms) of refrigerant in the tank. Add refrigerant to the tank.
- CAL** The scale is out of calibration. Calibrate the scale.
- CH-F** The unit has recovered 300 pounds of refrigerant. Press **SHIFT/RESET** and **FILTER** at the same time, then replace the filter-drier.
- CH-P** The vehicle's A/C system has less than 25 psi. Do **not** attempt recovery if the A/C system has no refrigerant. Check for restrictions at access fittings. Check the manifold valve positions (they should be open). To continue, press **HOLD/CONT.**
- CL-L** The low side clearing routine is in progress. This occurs when you press **RECOVER** and can last up to four minutes.
- CLR** The unit is in the self-clearing process.
- CON** The vacuum pump will run continuously. Press **SHIFT/RESET** to stop.
- CPL** The specified cycle function (recovery, evacuation, charging or adding refrigerant) is complete.
- FIL** The filter-drier changeout is in progress.
- FULL** The refrigerant recovery tank is full. Replace the tank.
- HI-P** The discharge pressure is above 435 psi. Check to be sure the unit tank's red valve is open.
- OIL** The vacuum pump has run for 10 hours. While the "OIL" message is displayed, press **SHIFT/RESET** and **ENTER** at the same time to reset the timer. Then change the vacuum pump oil.
- SCAL** The scale is damaged, disconnected, out of calibration or overloaded (it cannot exceed 80 pounds or 36.3 kilograms). Calibrate the scale.
- U-HI** There is positive pressure on the vacuum pump. Press **SHIFT/RESET** and then **RECOVER** to remove the pressure, then continue the evacuation procedure.
- 99LB** The maximum amount displayed during recovery is 99 pounds (or 99 kilograms). Press **SHIFT/RESET** to clear the display.

Replacement Parts List

The following is a list of replacement parts and accessories you may need to service or maintain your unit.

The 50-pound (23 kilograms) refillable refrigerant tank is the only tank you should use with this unit. The unit's overfill limitation mechanism has been calibrated specifically for use with this tank, and the tank's valving is set up specifically for use with this unit.

We suggest you keep several filter-driers on hand so you will always be able to change them and complete any recycling job that is in progress.

Premium High Vacuum Pump Oil is also available in handy quart containers or in convenient gallon containers:

Quart (shipped 12 quarts per case) 13203

Gallon (shipped 4 gallons per case) 13204

**Because of ongoing product
improvements, we reserve the right
to change design, specifications, and
materials without notice.**

Replacement Parts List

Component	Series	Series	Series	Series
	17700A	17701A	34700	34701
	115-Volt	220-Volt	115-Volt	220-Volt
50 lb. (23 kg) Tank	17506	17506	34750	34750
36" Red Hose	68336	68336	RA19077	RA19077
36" Blue Hose	68236	68236	RA19079	RA19079
36" Yellow Hose	RA19205	RA19205	RA19078	RA19078
96" Red Hose	RA19438	RA19438	RA19434	RA19434
96" Blue Hose	RA19439	RA19439	RA19435	RA19435
Fan	RA17416	RA17516	RA17416	RA17516
Filter-Drier	34724	34724	34724	34724
Compressor	RA19458	RA19457	RA19458	RA19457
Vacuum Pump	RA15525	RA15526	RA15525	RA15526
High Pressure Switch	RA19427	RA19427	RA19427	RA19427
Main Power Switch	RA40994	RA17135	RA40994	RA17135
Vacuum Switch	RA19428	RA19428	RA19428	RA19428
Pump Protection Switch	RA19429	RA19429	RA19429	RA19429
Automatic Expansion Valve	RA19430	RA19430	RA19430	RA19430
Oil Drain Valve	RA19291	RA19291	RA19291	RA19291
Oil Catch Bottle	RA17419	RA17419	RA17419	RA17419
Scale Assembly	RA19469	RA19469	RA19469	RA19469
Main Circuit Board	RA19432	RA19432	RA19432	RA19432
High Side Gauge	RA19393	RA19393	RA19393	RA19393
Low Side Gauge	RA19392	RA19392	RA19392	RA19392
Low Side Coupler	N/A	N/A	18190A	18190A
High Side Coupler	N/A	N/A	18191A	18191A
Vinyl Dust Cover	17495	17495	17495	17495
Automatic Air Purge	RA19433	RA19433	RA19433	RA19433
Relays	RA17459	RA17459	RA17459	RA17459
Transformer	N/A	RA19091	N/A	RA19091
Sound Alert	RA19066	RA19066	RA19066	RA19066
Wheels and Speed Nut	10751	10751	10751	10751
Solenoid Rebuild Kit	RA19258	RA19258	RA19258	RA19258

Flow Diagram

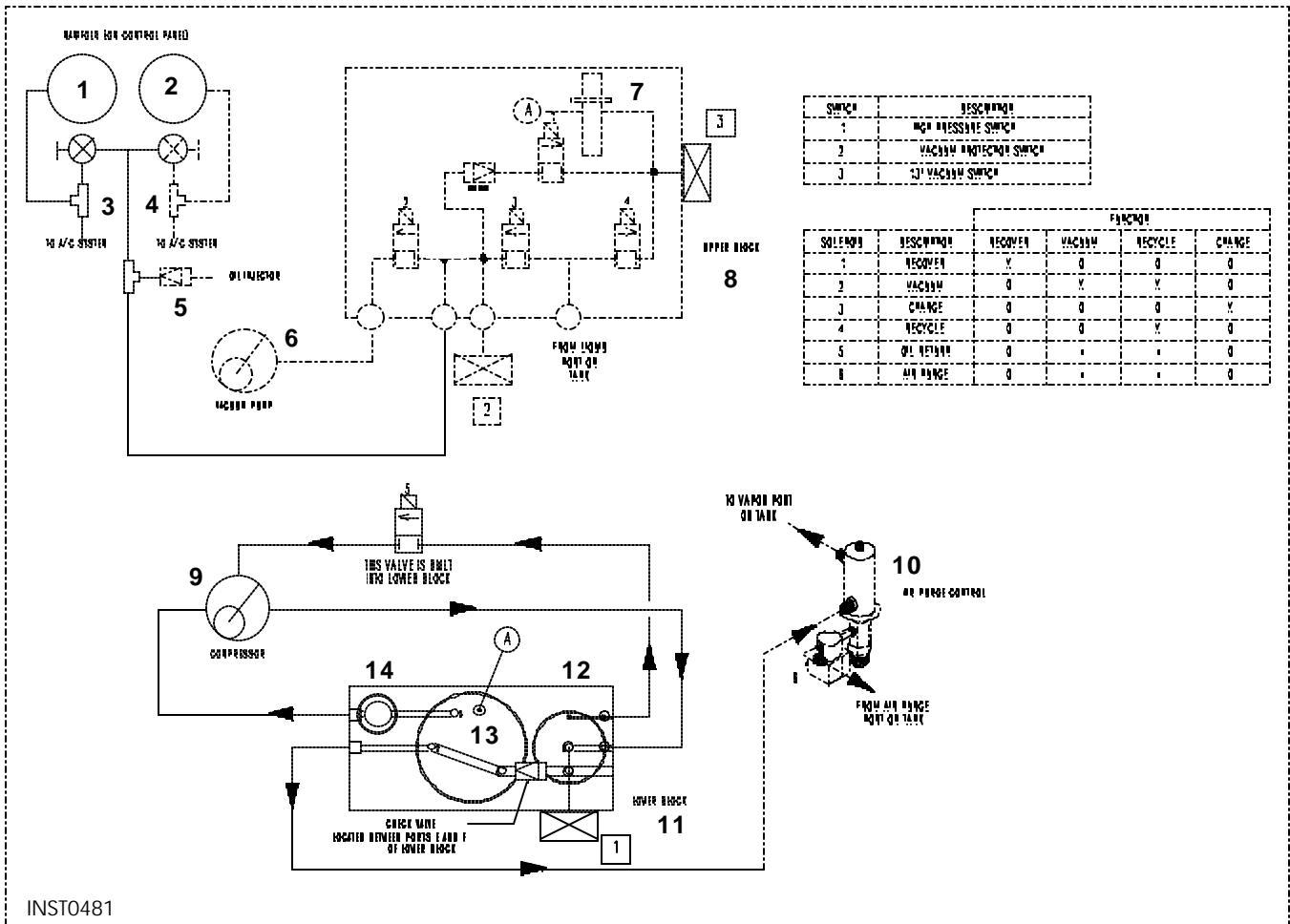

INST0481

1. Low Side Manifold Gauge
2. High Side Manifold Gauge
3. Low Side Manifold Valve
4. High Side Coupler
(34700/34701 only)
5. Oil Injector Check Valve
6. Vacuum Pump
7. Expansion Valve
8. Upper Block
9. Compressor
10. Air Purge Control
11. Lower Block
12. Return Oil Separator
13. Accumulator
14. Filter-Drier

Wiring Diagram

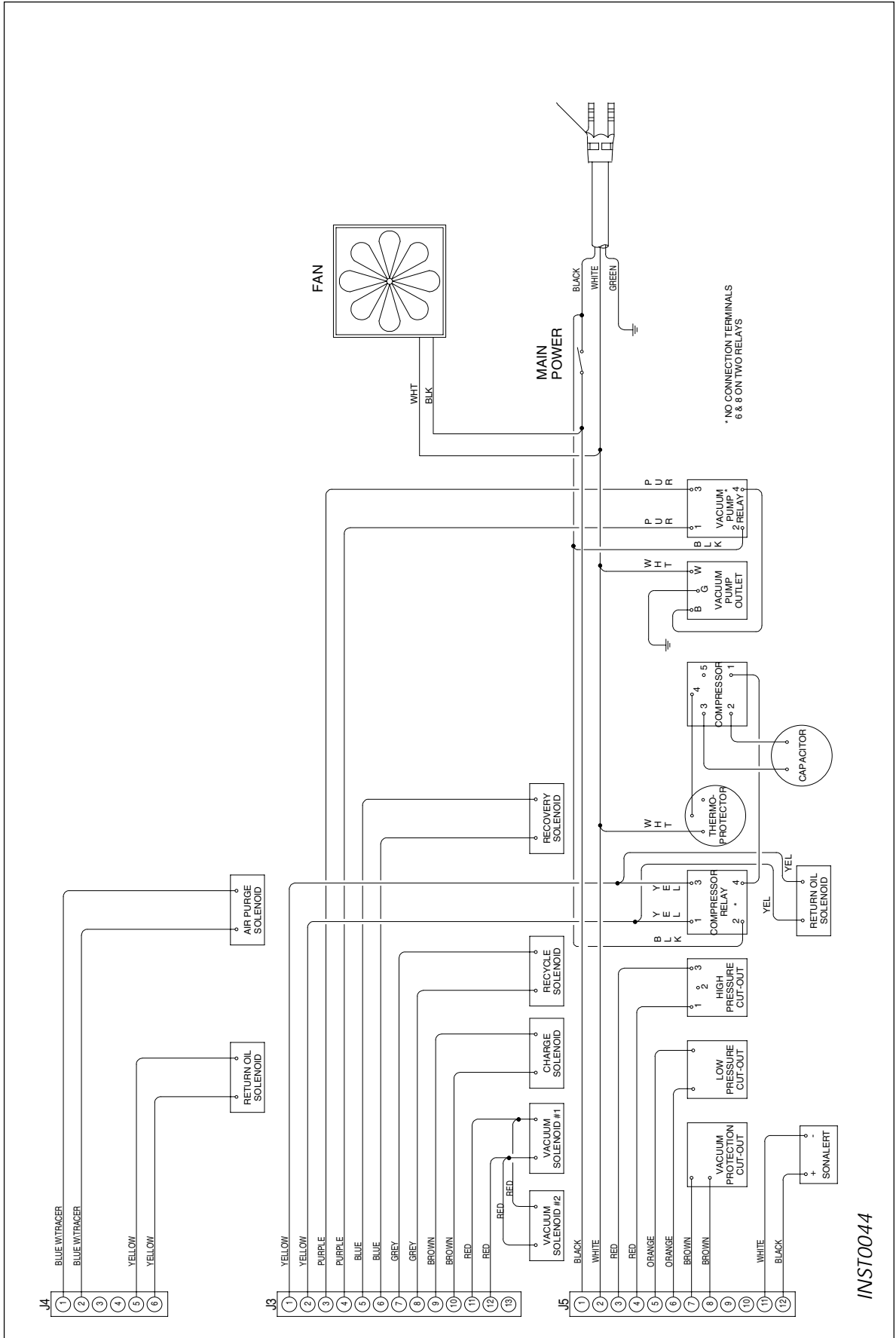

INST0044

This product is warranted to be free from defects in workmanship, materials and components for a period of one year from date of purchase. All parts and labor required to repair defective products covered under the warranty will be at no charge. The following restrictions apply:

1. The limited warranty applies to the original purchaser only.
2. The warranty applies to the product in normal usage situations only, as described in the Operating Manual. The product must also be serviced and maintained as specified.
3. If the product fails, it will be repaired or replaced at the option of the manufacturer.
4. Transportation charges for warranty service will be reimbursed by the factory upon verification of the warranty claim and submission of a freight bill for normal ground service. Approval from Robinair must be obtained prior to shipping to either an authorized service center or the factory.
5. Warranty service claims are subject to factory inspection for product defect(s).
6. Robinair shall not be responsible for any additional costs associated with a product failure including, but not limited to, loss of work time, loss of refrigerant, and unauthorized shipping and/or labor charges.
7. All warranty service claims must be made within the specified warranty period. Proof-of-purchase date must be supplied to the manufacturer.
8. Use of Robinair recovery/recycling equipment with unauthorized refrigerants will void our warranty. Authorized refrigerants are listed on the equipment or are available through our Technical Service Department.

This Limited Warranty does not apply if:

- The product, or product part, is broken by accident.
- The product is misused, tampered with, or modified.
- The product is used for recovering or recycling any substance other than the specified refrigerant type.

Note: Refillable refrigerant tanks are reusable. Do not return them to the factory, unless the tank is defective.