



ROBINAIR

Operating Manual

Series 12134B
Recovery/Recycling/Recharging Unit
for R-12 and R-134a

LISTED



80S2

Design Certified by Underwriters Laboratories Inc.® to meet SAE J1770 for recycling R-12 and R-134a using common refrigerant circuits



ROBINAIR
Refrigerant Recovery,
Recycling, and Recharging Station

Series: 12134B

Refrigerants: R-12 and R-134a

⚠ WARNING ⚠

PRESSURIZED TANK CONTAINS LIQUID REFRIGERANT. OVERFILLING OF THE TANK MAY CAUSE VIOLENT EXPLOSION AND POSSIBLE INJURY OR DEATH. Safety devices require the use of only authorized refillable refrigerant tanks. Refer to the instruction manual for tank specifications and ordering information. Do not recover refrigerants into a non-refillable storage container! Federal regulations require refrigerant to be transported only in containers meeting DOT spec. 4BW or DOT spec. 4BA.

ALL HOSES MAY CONTAIN LIQUID REFRIGERANT UNDER PRESSURE. Contact with refrigerant may cause injury. Wear proper protective equipment, including safety goggles. Disconnect hoses with extreme caution.

HIGH VOLTAGE ELECTRICITY INSIDE PANELS. RISK OF ELECTRICAL SHOCK. Disconnect power before servicing unit. Refer to the instruction manual.

REDUCE THE RISK OF FIRE. Avoid the use of an extension cord because the extension cord may overheat. If an extension cord must be used, it must be No. 14 AWG minimum and as short as possible. Do not use this equipment in the vicinity of spilled or open containers of gasoline or other flammable substances.

Use this equipment in locations with mechanical ventilation that provides at least four air changes per hour or locate the equipment at least 18 inches above the floor.

Make certain that all safety devices are functioning properly before operating the unit. Before operating, read and follow the instructions and warnings in the operating manual.

CAUTION: SHOULD BE OPERATED BY QUALIFIED PERSONNEL. Operator must be familiar with air conditioning and refrigeration systems, refrigerants and the dangers of pressurized components.

Use this unit with R-12 or R-134a systems only. This equipment is not designed for any other purpose than recovering, recycling or recharging refrigerants! Do not mix refrigerant types!

ATTENTION!

Ce réservoir sous pression contient du frigorigène liquide. S'il est surchargé, ce réservoir peut exploser et causer des blessures ou la mort.

ATTENTION. Débrancher avant la maintenance.

ATTENTION. Pour réduire les risques d'incendie, ne pas utiliser de cordon prolongateur de section inférieure à 14 AWG de façon à éviter la surchauffe du cordon.

ATTENTION. Utiliser seulement du frigorigène R-12 ou R-134a.

OPERATING NOTES

1. Press SHIFT/RESET until the "CLR" message appears in the display.
2. Press HOLD/CONT. The unit will begin clearing refrigerant. This takes approximately 20 minutes.
3. When the changeover is complete, the "CPL" message will be displayed.
4. Move the refrigerant selector switch to the appropriate refrigerant type (R-12 or R-134a).

R-134a WARNINGS!

Cross-contamination with other refrigerant types will cause severe damage to the A/C system and to service tools and equipment. Do not mix refrigerant types through a system or in the same container!

Avoid breathing A/C refrigerant and lubricant vapor or mist. Exposure may irritate eyes, nose and throat. To remove R-134a from the A/C system, use service equipment certified to meet the requirements of SAE J1770 (R-134a recycling equipment). If accidental system discharge occurs, ventilate work area before resuming service.

HFC-134a service equipment or vehicle A/C systems should not be pressure tested or leak tested with compressed air. Some mixtures of air/HFC-134a have been shown to be combustible at elevated pressures. These mixtures are potentially dangerous and may result in fire or explosion causing injury or property damage.

Additional health and safety information may be obtained from refrigerant and lubricant manufacturers.

This manual contains important safety procedures concerning the operation, use and maintenance of this product. Failure to follow the instructions contained in this manual may result in serious injury. If you are unable to understand any of the contents of this manual, please bring it to the attention of your supervisor. Do not operate this equipment unless you have read and understood the contents of this manual.

TABLE OF CONTENTS

Introduction	1
Glossary of Terms	2
Operating Guidelines	3
Set Up Instructions	8
Operating Instructions	21
Operating Overview	34
Maintenance Instructions	37
Troubleshooting Tips	44
Replacement Parts List	52
Flow Diagram.....	54
Wiring Diagram	55
Warranty.....	56

See Index (57) for a complete listing of all procedures and diagrams.

GLOSSARY OF TERMS

A/C System	The air conditioning system being serviced
Unit	The refrigerant recovery/recycling/recharging unit
Unit Tank	The refillable refrigerant tank designed specifically for this unit
Source Tank	A disposable tank of new refrigerant used to refill the unit tank

IMPORTANT OPERATING INFORMATION

This station is designed to meet minimum SAE specifications for cross-contamination and refrigerant purity. If the machine is not operated according to the instructions in this manual, cross-contamination of the refrigerant supply can occur; this will require disposal of the refrigerant in the tank. Also, incorrect operation and any resulting cross-contamination have the potential to damage any system charged with the refrigerant. Important points to remember:

- After each recovery, open the oil drain valve and thoroughly drain any system oil that has been collected.
- Always change filters and vacuum pump oil at recommended times.
- Always run at least a minimum recycling or vacuum/recycling operation to assure proper purging of non-condensibles.
- All unit functions are interdependent for proper operation. Do not ignore problems that occur in any of the procedures. At the first sign of a problem, call the toll-free Technical Support Line for assistance.

CONTROL PANEL COMPONENTS

The control panel has various components that control specific operating functions. The **MAIN POWER** switch and moisture indicator are located on the back panel of your unit.

MAIN POWER Switch — Supplies electrical power to the control panel.

Beeper — Emits an audible tone to alert you to unit operating functions. The beeper is located on the underside of the control panel below the keypad.

Digital Display — Shows the time programmed for vacuum and the weight of refrigerant programmed for recharging. Detailed instructions for programming the digital display follow this section.

LOW Side Gauge — Connects to an A/C system and shows the system's low side pressure.

HIGH Side Gauge — Connects to an A/C system and shows the system's high side pressure.

Moisture Indicator — Shows if the refrigerant is wet or dry.

LOW Side Valve — Controls the low side flow from the A/C system through the unit.

HIGH Side Valve — Controls the high side flow from the A/C system through the unit.

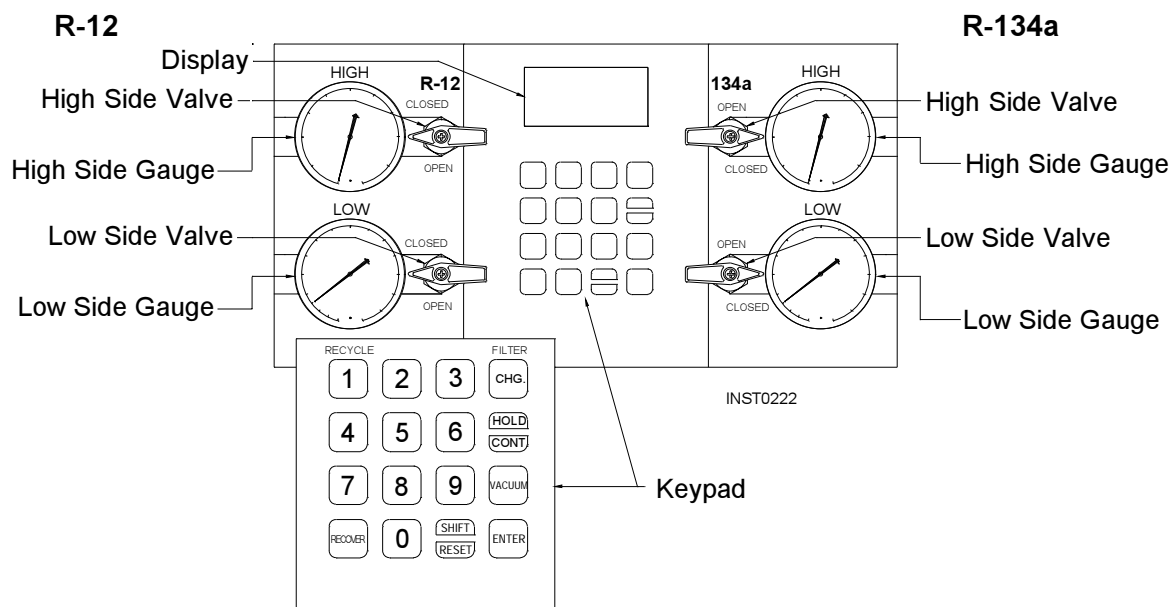
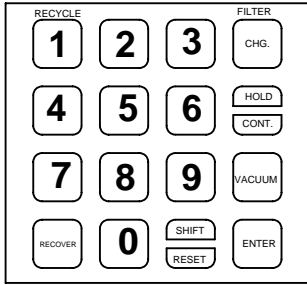

Diagram of Control Panel



0413-11

Diagram of Keypad

KEYPAD FUNCTIONS

In addition to the number keys, the keypad contains special keys that accomplish specific operating functions.

- **RECYCLE** — Activates the recycling sequence when pressed at the same time as the **SHIFT/RESET** key.
- **RECOVER** — Activates the recovery sequence.
- **SHIFT/RESET** — Accesses the PROGRAM mode and moves you from one program function to the next.
- **FILTER** — When pressed at the same time as the **SHIFT/RESET** key, automatically recovers and evacuates from the filter and low side of the unit so you can change the filter.
- **CHG** — Automatically charges the A/C system with the programmed amount of refrigerant.
- **HOLD/CONT** — Interrupts the AUTOMATIC cycle (HOLD), then resumes functions (CONT). Press once for **HOLD**, and again for **CONT** (continue).
- **VACUUM** — Activates the vacuum and automatic recycling sequence.
- **ENTER** — Enters programmed data into the unit memory.

DIGITAL DISPLAY MESSAGES

This section explains the messages shown on the digital display, which is illustrated below.

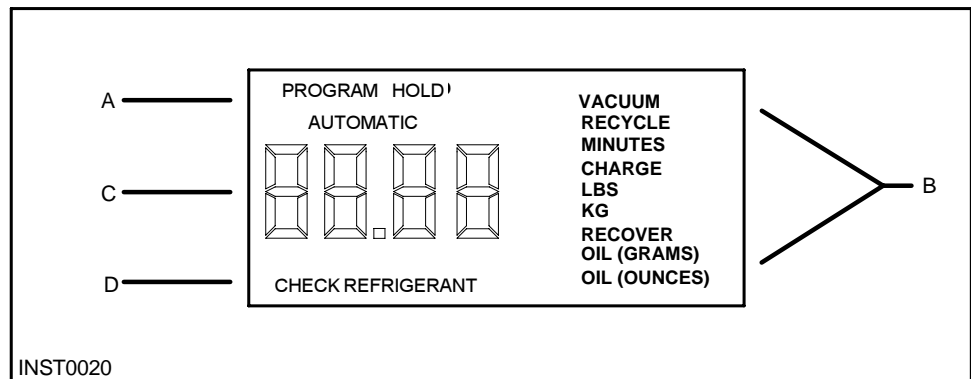

INST0020

Diagram of Digital Display

Segment A — Indicates the current operating mode:

PROGRAM — The unit is in the PROGRAM mode, which allows you to program vacuum time and refrigerant weight **or** to review the existing program.

HOLD — This mode is used to change a refrigerant tank or to interrupt the vacuum/charging/recovery cycles.

AUTOMATIC — Indicates that the unit is running in a given cycle and will automatically stop when the cycle is complete.

Segment B — Indicates that the unit is either evacuating the A/C system **or** recovering, recycling, or recharging refrigerant **or** that the unit is ready to be programmed for one of these functions:

(See the chart below for a quick reference of these segments.)

VACUUM

- With PROGRAM, indicates that the unit is ready to be programmed for vacuum.
- With AUTOMATIC, indicates that the vacuum pump is running; the number displayed counts down in minutes and seconds, showing the amount of time remaining.
- With HOLD, indicates that **HOLD/CONT** was pressed to interrupt the vacuum cycle.

Use chart as a quick reference for interpreting Segment B messages.

VACUUM	+	PROGRAM	=	Program unit for vacuum
VACUUM	+	AUTOMATIC	=	Vacuum pump is running
VACUUM	+	HOLD	=	Interrupted vacuum cycle
RECYCLE	+	AUTOMATIC	=	Unit is recycling refrigerant
CHARGE	+	PROGRAM	=	Program unit for charge
CHARGE	+	AUTOMATIC	=	Unit is charging A/C system
CHARGE	+	HOLD	=	Interrupted charging cycle
RECOVER	+	AUTOMATIC	=	Unit is recovering refrigerant

RECYCLE

- With **AUTOMATIC**, indicates the unit is recycling refrigerant from the tank.

CHARGE

- With **PROGRAM**, indicates that the unit is ready to be programmed for the amount of refrigerant to be charged into the A/C system; on the keypad enter the charge in pounds and hundredths of a pound.
- With **AUTOMATIC**, indicates the unit is charging refrigerant into the A/C system; the number shown on the digital display counts down, showing the remaining amount of refrigerant to be dispensed.
- With **HOLD**, indicates that **HOLD/CONT** was pressed to interrupt the charging cycle; the number shown on the digital display is the amount of refrigerant remaining to be charged into the A/C system; to continue charging, press **HOLD/ CONT** again.

RECOVER

- With **AUTOMATIC**, indicates the unit is recovering refrigerant from the A/C system and shows the amount of refrigerant recovered in pounds.

OIL(OUNCES)

- Lights up as a reminder to drain the oil separator after each job.

Segment C — Shows a number or a coded error message on the digital display that indicates the unit's operating status or any specific problems. See "Troubleshooting Tips" for a list of error codes and messages.

Segment D — Indicates that refrigerant is low — approximately 6 pounds of refrigerant is left in the tank. Either replace the tank or add refrigerant as described in "Adding Refrigerant to the Tank."

USING MANUAL DIAGNOSTICS



Be sure to discharge AC system pressure before performing any manual diagnostics or be sure all refrigerant has been recovered from the AC system before performing any diagnostics.

This unit's manual diagnostics mode is easily accessible through the keypad.

1. Press **SHIFT/RESET** and **ENTER** at the same time. The display will show the message "FUNC."
2. Press the following keys to perform these functions:

Press "1" — Starts the vacuum pump to begin evacuation. To interrupt evacuation, press **HOLD/CONT**. To resume operation, press **HOLD/CONT** again.

Press "2" — Begins the transfer of refrigerant. The "ADD" message displays momentarily, then the display shows the amount of refrigerant transferred. Press **HOLD/CONT** at any time to interrupt the transfer, then press **HOLD/CONT** again to continue.

Press "3" — Displays the total amount of refrigerant recovered. Each time recovery is completed, the latest amount is added to the existing total. To clear the internal counter, press **SHIFT/RESET** and **ENTER** at the same time while the total is being displayed. The maximum amount recorded is 9,999 pounds of refrigerant.

Press "5" — All display segments light up.

Press "6" — Automatically sets the scale to "0" then displays the approximate weight added to the scale.

Press "7" — Displays the approximate weight of refrigerant contained in the tank.

Press "9" — Allows access to the scale calibration feature.

Press "0" — Automatically switches from pounds to kilograms.

Press HOLD — Performs a manual air purge.

3. Press **SHIFT/RESET** to return to the PROGRAM mode.

Set Up Instructions

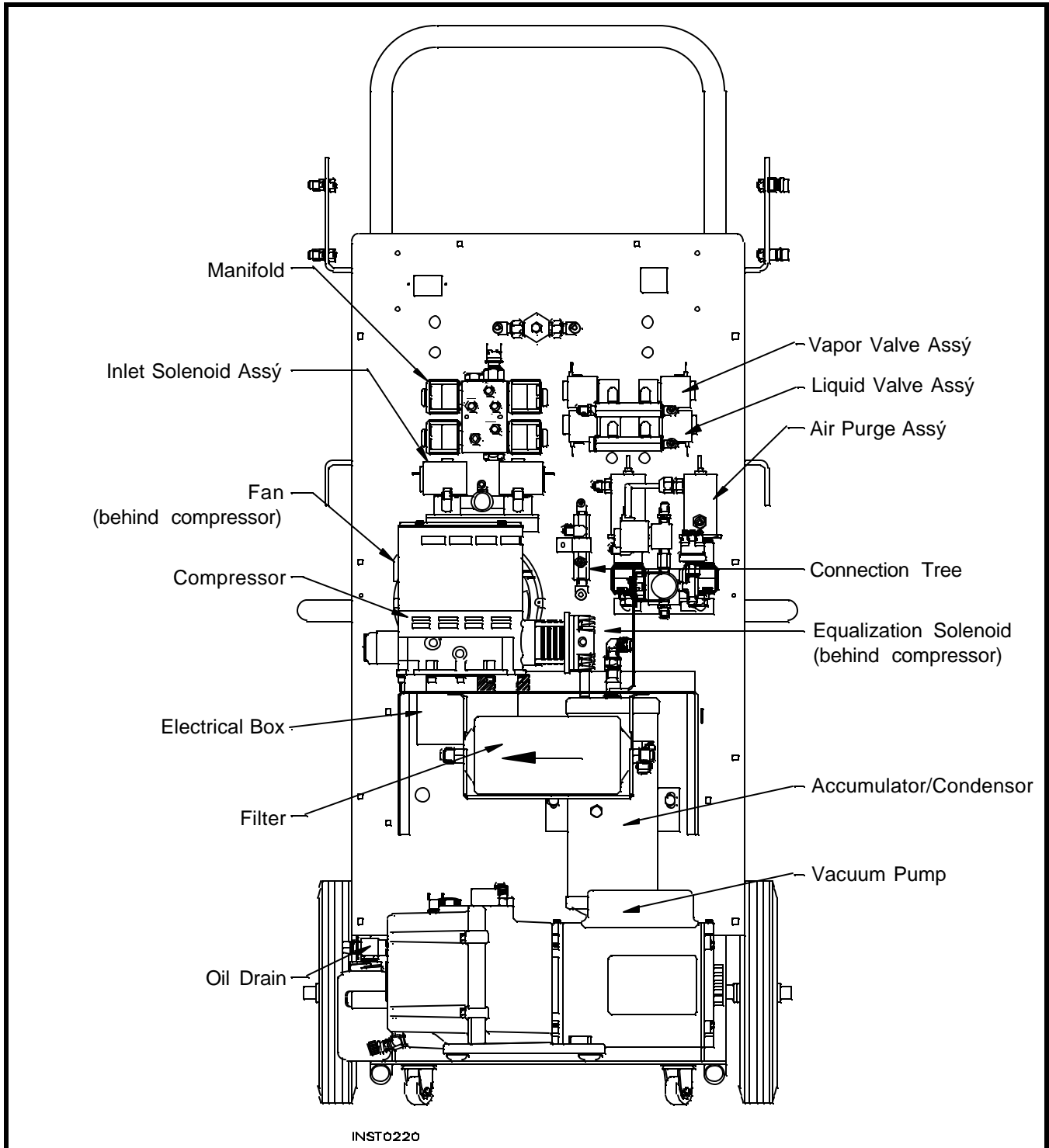

Diagram of Unit's Components — Internal View

Set Up Instructions

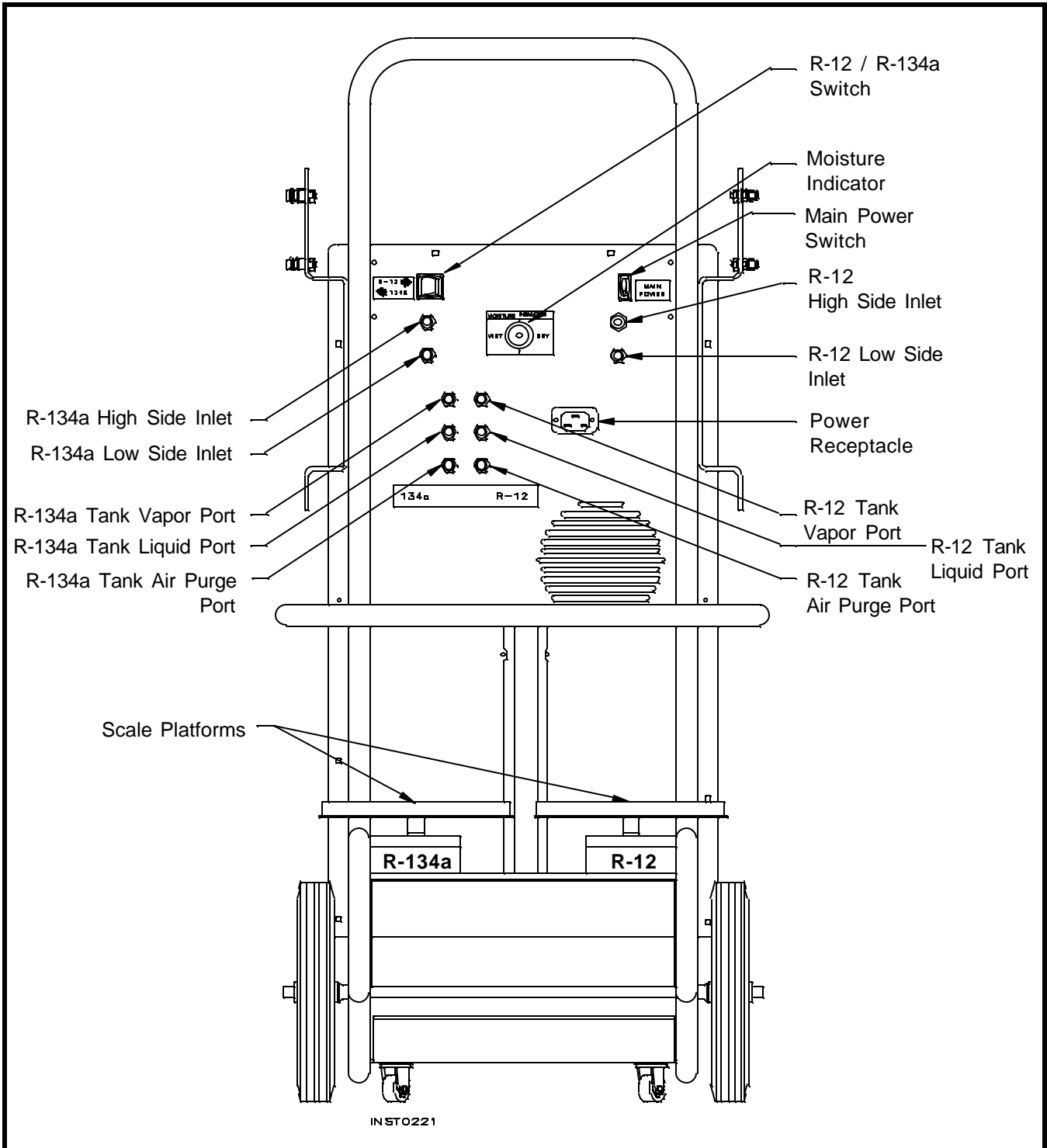

Diagram of Unit's Components — Rear View

Set Up Instructions

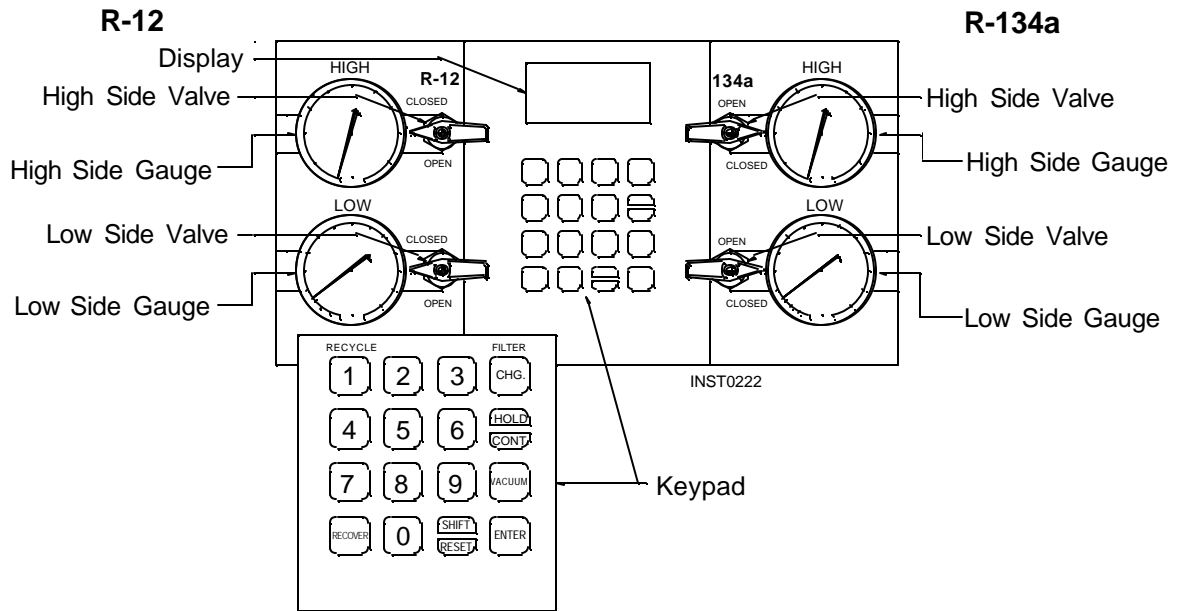

Diagram of Control Panel and Keypad

PREPARING THE VACUUM PUMP

The VacuMaster® vacuum pump is shipped without oil in the reservoir. Before starting the unit, you must fill the pump with oil. Two 16-ounce (472 milliliters) bottles of oil are included with your unit.

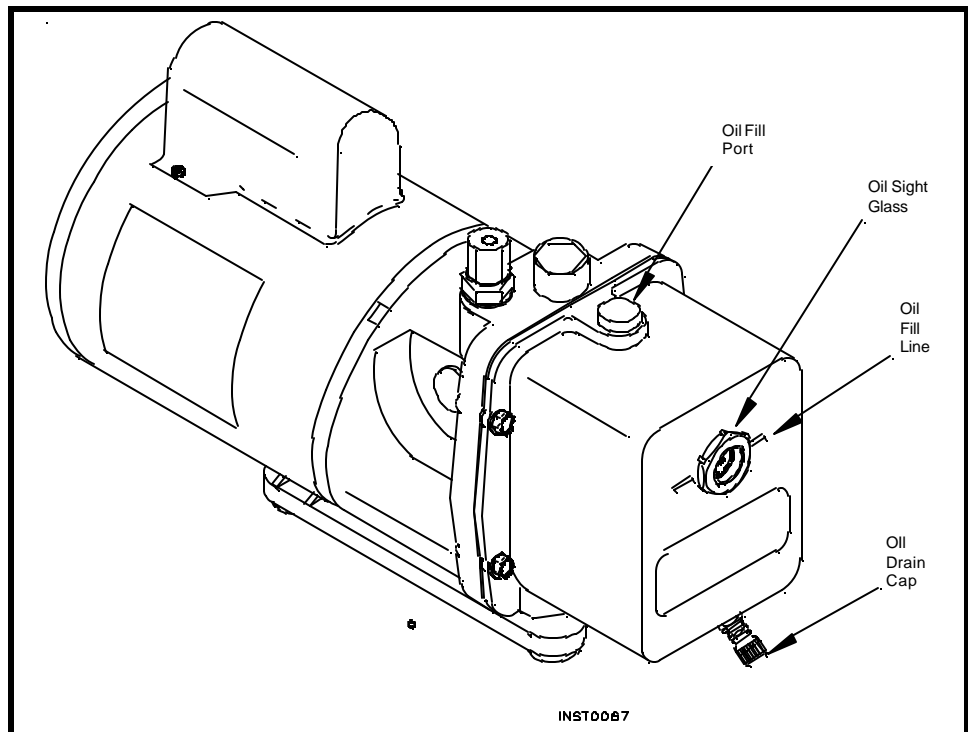

Diagram of Vacuum Pump Components

Set Up Instructions

Before starting the set up procedures, open the oil drain valve and allow the unit to depressurize.

1. Plug the unit into a proper voltage outlet.

CAUTION! Avoid the use of an extension cord. It may overheat. If you must use an extension cord, use No. 14 AWG minimum and keep the length to 25 feet (7.6 meters) or less.

2. Be sure the oil drain valve is closed.
3. Turn on the unit. The display will flash the current position of the refrigerant switch.
4. Before adding oil to the vacuum pump, be sure both sets of manifold valves are closed.
5. Remove the access door from the front of the unit. Remove the black plastic plug from the pump's oil fill port. Attach the flexible spout and cap to the bottle of oil included with your unit (this makes it easier to fill the pump).
6. Select the correct refrigerant switch position before pressing any keys.
7. Press **SHIFT/RESET**. The display shows the 15-minute vacuum default time.
8. Add six to eight ounces of vacuum pump oil to the pump (approximately half the bottle supplied with your unit).
9. Press **SHIFT/RESET** and **ENTER** at the same time. When the display shows the "Func" message, press "1" to start the vacuum pump.
10. While the pump is running, pour oil into the pump's oil fill port until the level of oil is even with the line on the pump reservoir sight glass.
11. Press **HOLD** to stop the pump, then press **SHIFT/RESET** to return to the program mode.
12. Replace the black plug on the oil fill port. Replace the front access door.

See the "Maintenance Instructions" for step-by-step procedures for changing the vacuum pump oil.



Func

IMPORTANT!
Be sure the pump is running when adding the rest of the oil to the pump. Do not overfill the pump. The approximate oil charge is 13 ounces (384 milliliters).



Func

INST0235

SELECTING A MEASUREMENT UNIT

The next step in setting up your unit is to select the unit of measure (either pounds or kilograms) to be used when operating the unit.

1. Press **SHIFT/RESET** and **ENTER** at the same time.
2. When the “Func” message appears on the display, press “0.” The display will indicate that a unit of measure has not been set.
3. Press **ENTER** to toggle between the units of measure.
4. When the desired unit of measure is displayed, press **SHIFT/RESET**.



KC



ENTER



LBB

INST0297

INSTALLING THE TANK AND PULLING A VACUUM

⚠ WARNING ⚠

Always wear safety goggles when working with refrigerant. Use only authorized refillable refrigerant tanks. Read and follow all warnings at the beginning of this manual before operating the unit.

CAUTION! R-134a systems have special fittings (per SAE specifications) to avoid cross-contamination with R-12 systems. Do not attempt to adapt your unit for any other refrigerant — system failure will result!

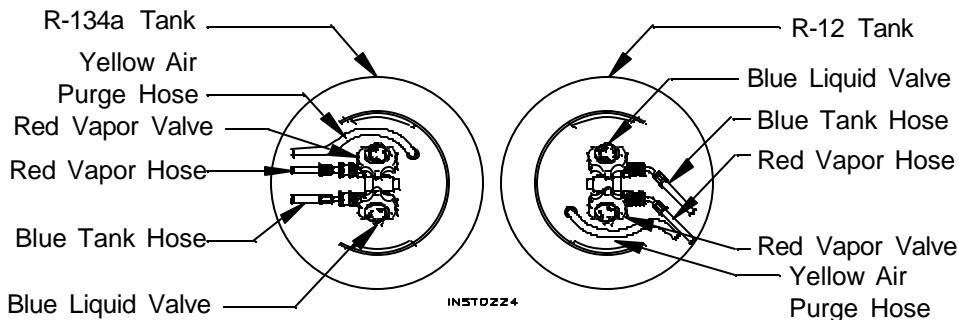

IMPORTANT:
Valves on tank may not be as shown. Always follow markings on valve handle; Liquid (Blue), Vapor/Gas (Red)

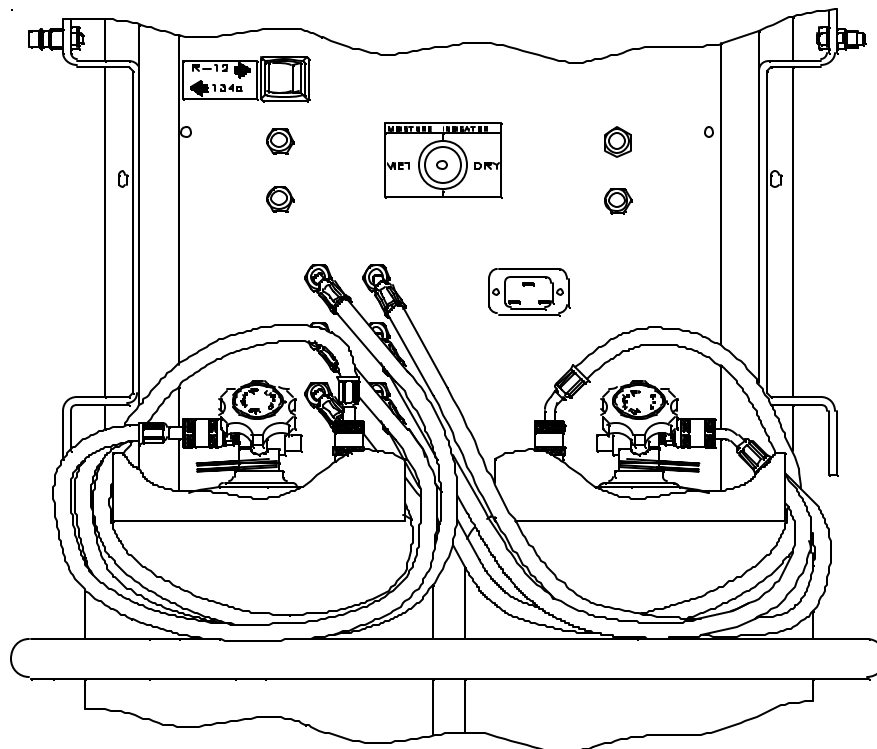

Diagram of Tank Installation

IMPORTANT:
Attach the Quick-Seal ends of the hoses to the tanks.

Attach the 45° standard fittings to the unit. These fittings must be angled toward the center of the unit.

Hoses must be routed between the tanks. Accuracy of the scales may be affected by hoses leaning on the tanks.

Set Up Instructions

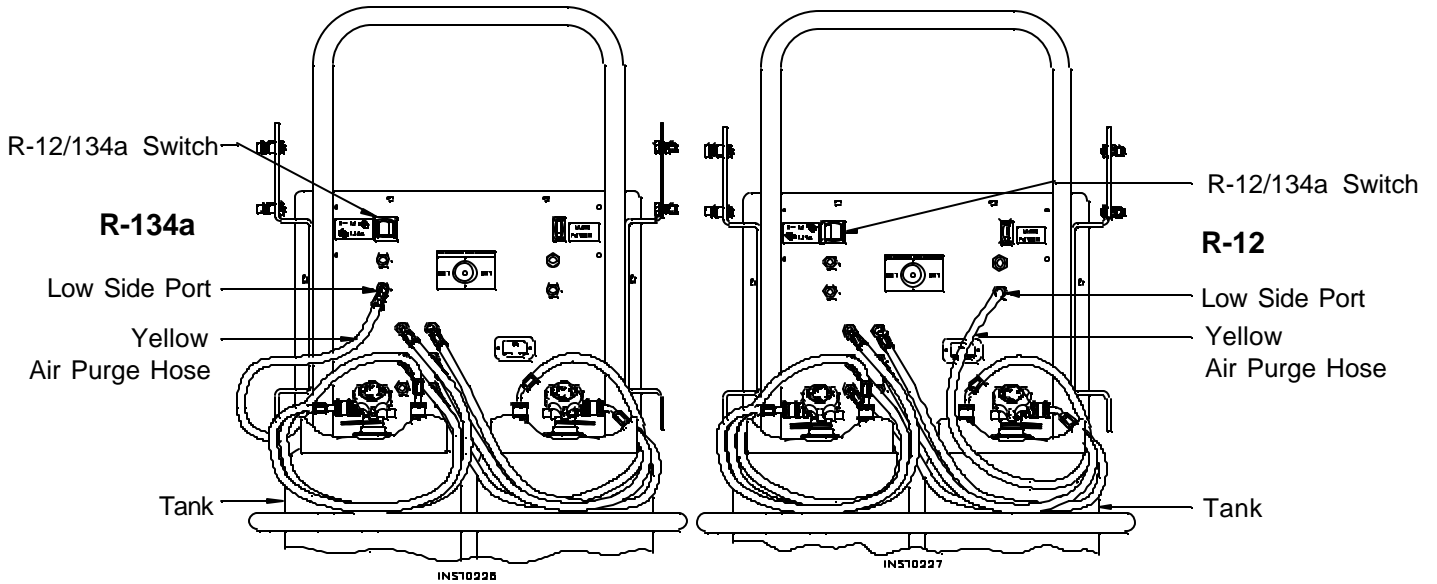
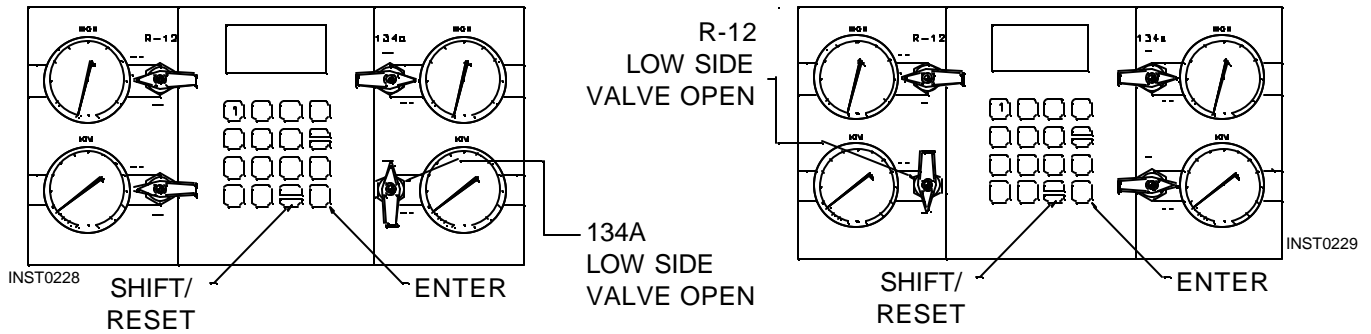

Diagram of Tank Connections During Evacuation

1. A new tank comes with 5 to 10 psi of nitrogen gas to keep it clean and dry during shipment. Purge its nitrogen charge by opening the GAS (vapor) valve on the tank. Vent the pressure to the atmosphere, then close the valve.
2. Place the unit tanks on the scale platforms on the back of the unit inside the tank restraint bar. Securely tighten the thumb-screw on the platforms to hold the tanks in place.

CAUTION! Some tanks have slightly different valve configurations. Be sure to connect the red hose to the GAS (vapor) valve and connect the blue hose to the LIQUID valve.

3. Connect the 36 inch (91 cm) yellow air purge hose to the low side port on the unit and to the fitting on the unit tank.

Set Up Instructions

4. Connect the 36 inch (91 cm) red vapor hose on the unit to the GAS (vapor) valve on the unit tank.
5. Connect the 36 inch (91 cm) blue liquid hose to the LIQUID valve on the tank.

Before adding refrigerant, you must pull a vacuum on both the unit and the tank for five minutes to remove any air.

6. Open both valves on the tank.
7. Open the low side manifold valve on the control panel.
8. Press **SHIFT/RESET** and **ENTER** at the same time. The display shows the message “Func.”
9. Press “1.” The vacuum pump starts and runs continuously.
10. Let the pump run for a minimum of five minutes. A vacuum may then be pulled on the other refrigerant tank by changing the selector switch. Run a vacuum on this tank for a minimum of 5 minutes. After at least 5 minutes, set the selector switch on the required refrigerant type. Press **HOLD** to stop the pump. Press **SHIFT/RESET** to return to PROGRAM mode.

CAUTION! The procedure described in steps 1 through 10 is for new tanks only. It should be done only on initial set-up or after clearing cycle has been completed. Using this procedure for used tanks could damage the vacuum pump and/or allow cross-contamination to occur.

11. To maintain vacuum on the tank, close the low side valve on the control panel. Disconnect the 36 inch (91 cm) yellow hose from the tank on the unit **FIRST**, before disconnecting this hose from the back of the unit. Disconnecting in this order will prevent vacuum loss from the unit tank.
 - To partially fill a tank during initial set up, see “Partially Filling A Tank.”
 - To add refrigerant to the tank during normal operation, see “Adding Refrigerant to the Tank.”

NOTE: Any time the refrigerant type is flashing on the display, the refrigerant selector switch may be changed.

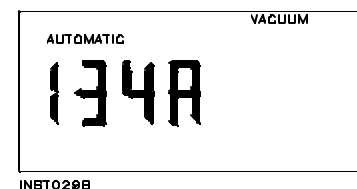
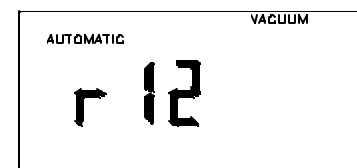
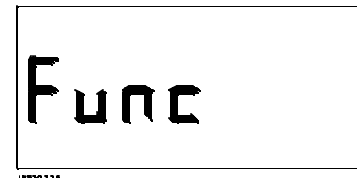

Set Up Instructions

R-134a or R-12

Open Appropriate Valves For System Being Serviced

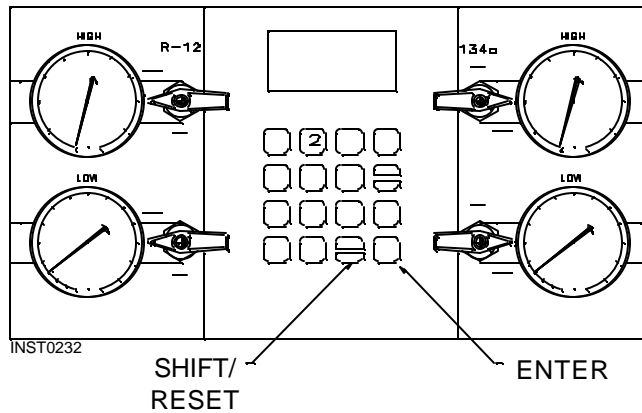

Diagram of Control Panel When Adding Refrigerant

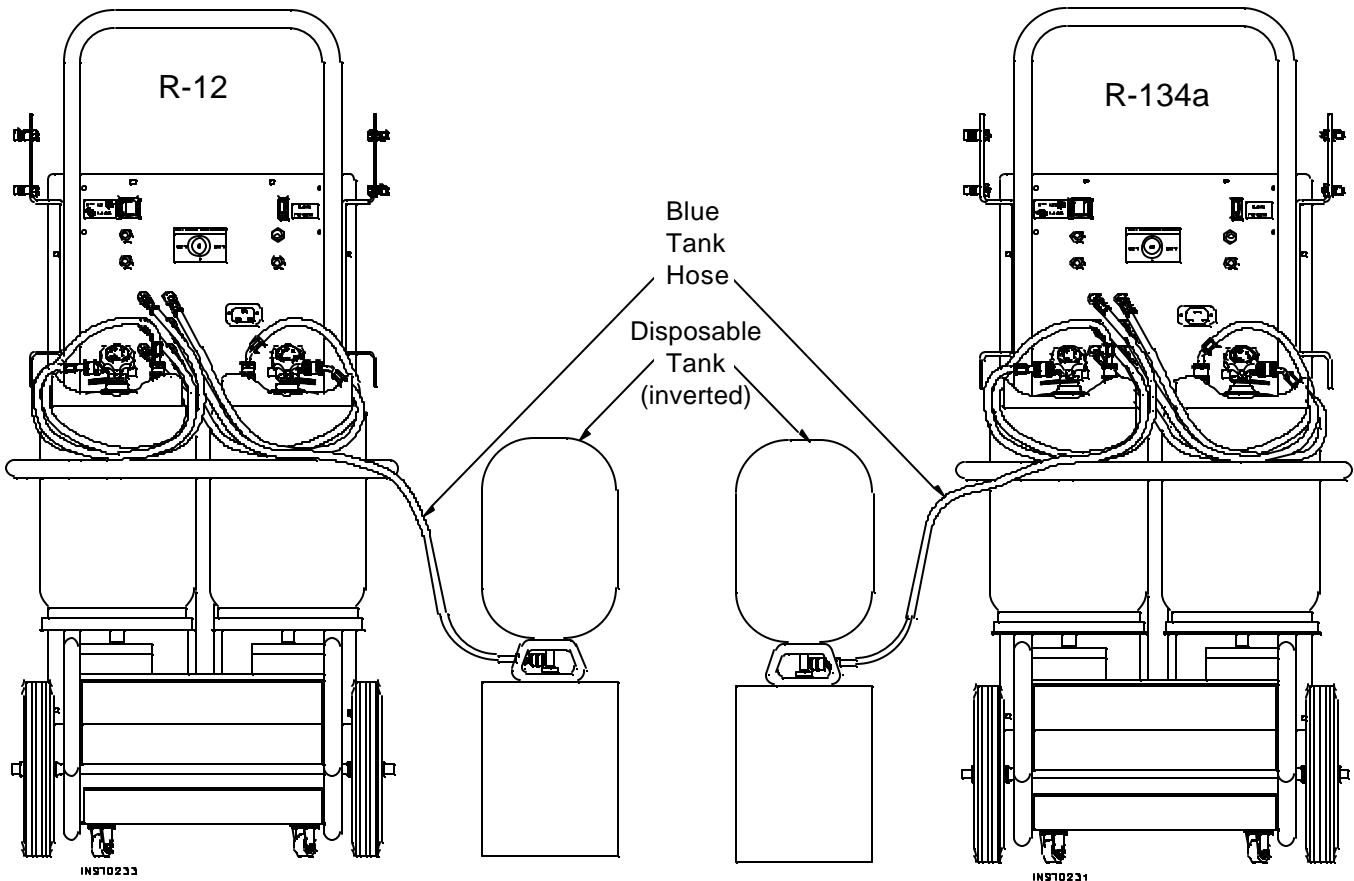

Diagram of Disposable Tank Connections When Adding Refrigerant

ADDING REFRIGERANT TO THE TANK

CAUTION! R-134a systems have special fittings (per SAE specifications) to avoid cross-contamination with R-12 systems. Do not attempt to adapt this unit for any other refrigerant — system failure will result! Read and follow all warnings given at the beginning of this manual.

NOTE: Purchase only tanks of R-134a refrigerant that have 1/2 inch (1.2cm) Acme threads. This is necessary to match the hose fittings.

1. Connect one end of the 36 inch (91 cm) yellow hose to the air purge port on the back of the unit, then connect the other end to the air purge fitting on the unit tank.
2. Close the LIQUID valve on the unit tank, and disconnect the 36 inch (91 cm) blue liquid hose from the valve.
3. **When using R-12**, connect the 6 inch (15.2 cm) yellow adapter to the source tank *first*. Then connect the 36 inch (91cm) blue LIQUID hose to the adapter.

When using R-134a, connect the blue liquid hose directly to the blue LIQUID valve of the source tank. Disposable tanks have only one valve and most must be turned upside down to transfer liquid. If you are using a disposable tank, follow the instructions on the side of the tank to obtain a liquid supply.

4. Open the LIQUID valve on the source tank (there is only one valve on a non-refillable tank).

CAUTION! Do not use the 96 inch (244 cm) blue low side hose! The blue LIQUID hose is the blue hose attached to the tank's LIQUID valve.

5. Open the red GAS (vapor) valve on the unit tank.

IMPORTANT!

When setting up for both types of refrigerant, a clearing process will have to be performed.

IMPORTANT!

The 96 inch (244 cm) red high side hose and the 96 inch (244 cm) blue low side hose are not used when adding refrigerant to the tank.

Set Up Instructions

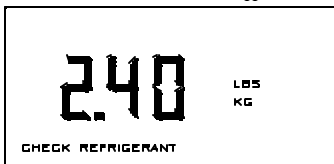
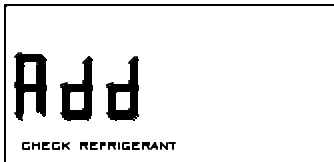

Weight Example *

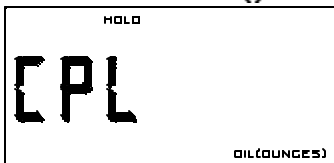

1879234

* The display shows the weight of refrigerant added to the tank.

6. Press **SHIFT/RESET** and **ENTER** at the same time to access the diagnostic mode. The display shows the message "Func."
7. Press **2** to begin transferring refrigerant. The display shows the "Add" message for about two seconds, then shows the amount of refrigerant transferred.
8. Transfer stops automatically and the display shows the "CPL" message when the source tank is empty and has been pulled to a partial vacuum **or** the weight of refrigerant in the unit tank reaches 15 pounds. The display toggles between "CPL" and the weight in the tank.

This process takes about 45 minutes. You can interrupt it at any time by pressing **HOLD/CONT** once. Press **HOLD/CONT** again to resume operation. The transfer of new refrigerant is limited by weight to leave space (about 10 pounds of refrigerant) in the unit tank for recovery purposes.

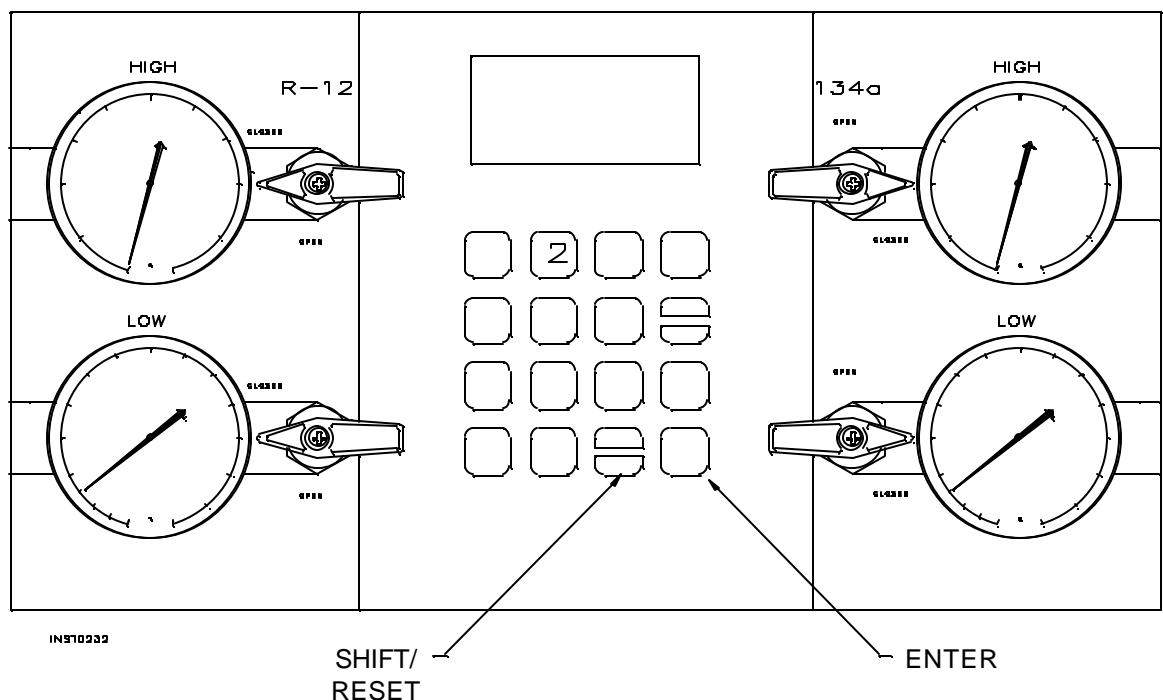

Diagram of Control Panel

9. **When using R-12**, close the supply valve on the source tank, and *carefully* disconnect the 36 inch (91 cm) blue liquid hose from the 6 inch (15.2 cm) yellow adapter, if used; then remove the 6 inch (15.2 cm) yellow adapter from the source tank.

When using R-134a with a disposable tank, turn the tank right side up, close its valve and *carefully* disconnect the 36 inch (91 cm) blue liquid hose.

10. Reconnect the 36 inch (91 cm) blue liquid hose to the LIQUID valve on the unit tank, then open that tank's LIQUID valve.
11. Connect the 96 inch (244 cm) red high side hose to the unit's high side port. You can also attach an oil injector to the unit's low side port. Oil injectors will not connect to the wrong ports. The R-12 oil injector has a $\frac{1}{4}$ inch flare connector; the R-134a oil injector has a $\frac{1}{2}$ inch Acme connector.
12. Connect the 96 inch (244 cm) blue low side hose to the unit's low side port or the oil injector, if used.

Any non-condensable gases in the tank will be removed during the recycling sequence. Your unit is now ready for use.

PARTIALLY FILLING A TANK

Follow these steps to partially fill the tank. This will not completely empty a 30-lb. (13.6 kg) tank.

1. Connect the end of the 36 inch (91 cm) yellow hose (was connected to the low port side) to the LIQUID valve of a 30-lb. (13.6 kg) disposable tank.
2. Connect the quick seal end of the 36 inch yellow hose to the unit tank air purge port.

If using the 6 inch (15.2 cm) yellow adapter, connect the adapter to the **R-12** source tank, then connect the adapter to the 36 inch (91cm) yellow air purge hose.

The adapter is not necessary with **R-134a**.

IMPORTANT!
Be sure to close both tank valves when the unit is not in use. Inspect the unit periodically for leaks. The manufacturer of the recovery/recycling unit does not reimburse for lost refrigerant.

Set Up Instructions

Disposable tanks have only one valve and generally must be turned upside down to transfer liquid. If you are using a disposable tank, follow the instructions on the side of the tank to obtain a liquid supply.

3. Open the LIQUID valve on the source tank (there is only one valve on a non-refillable tank).
4. Press **SHIFT/RESET** and **ENTER** at the same time, then press "7." The display shows the approximate refrigerant weight in the tank.
5. When the scale no longer shows a weight transfer (maximum - 30 pounds [13.6 kilograms]), close the valve on the disposable tank.
6. To prevent any release of refrigerant, follow this procedure to disconnect the yellow hose - carefully disconnect the 36 inch (91 cm) yellow hose from the unit tank, **then** from the source tank.

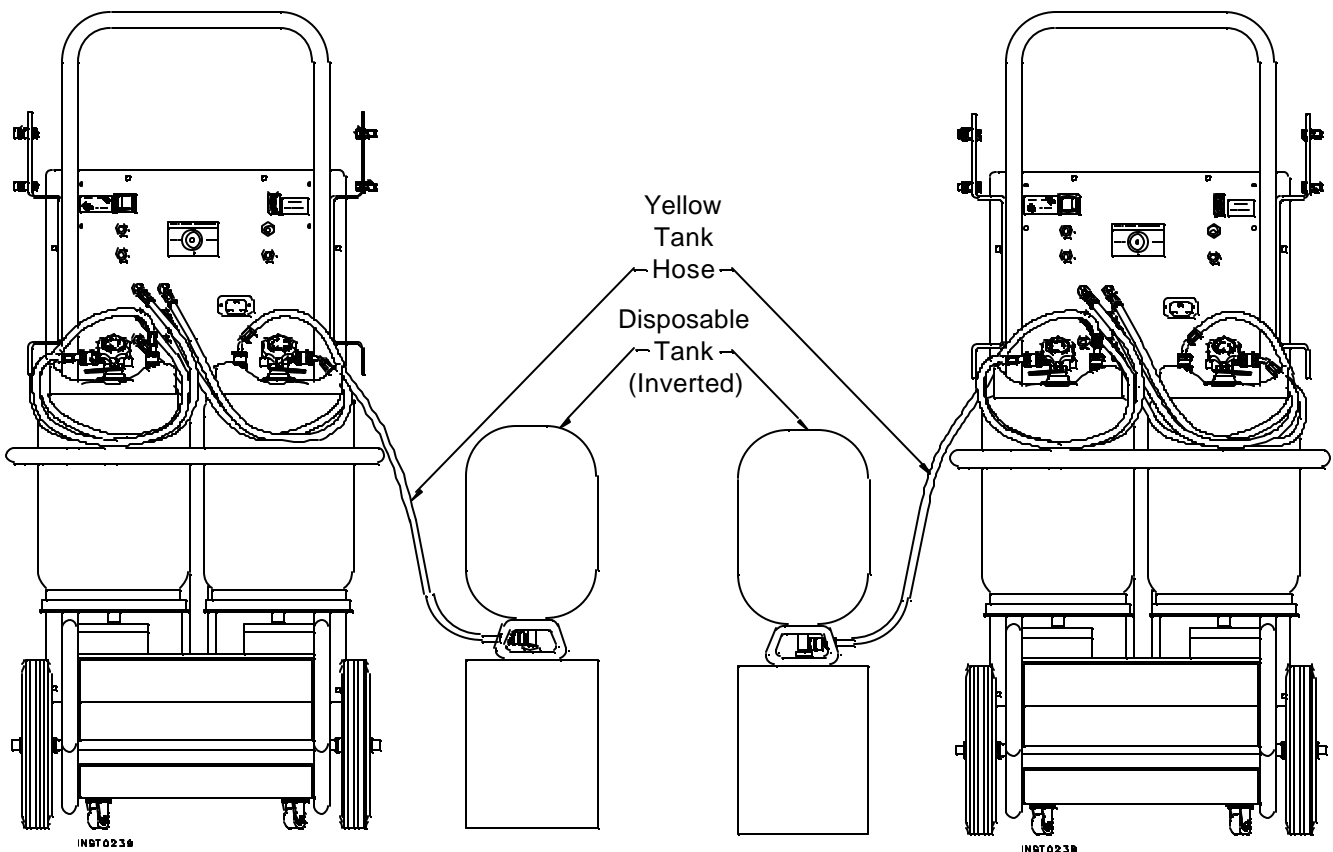

Diagram of Tank Connections When Partially Filling a Tank

OPERATING TIPS

Follow the SAE J-1989 recommended service procedure for the containment of R-12 and the SAE J-2211 recommended service procedure for the containment of R-134a.

The recovery compressor is *not* a vacuum pump. The compressor pulls the A/C system to a partial vacuum only. You must use the unit's vacuum cycle to remove moisture from the A/C system. We recommend a minimum 15-minute vacuum with more time as required by the system manufacturer.

This unit is designed to be used with the manifold gauge sets built into the control panel.

Also included is a 6 cfm (142 l/m) VacuMaster® high vacuum pump for fast, thorough evacuation. Be sure to change the vacuum pump oil when the “OIL” message appears on the display or more often when working on extremely contaminated systems.

R-134a systems require special oils in place of the mineral oil used with R-12 systems. Refer to the A/C system manufacturer's service manual for oil specifications.

CHANGING REFRIGERANT TYPES

Follow these steps to change the designated refrigerant type to either R-12 or R-134a and to prevent mixing of R-12 and R-134a.

1. Disconnect the red high side and blue low side hoses from the A/C system, then open the manifold and tank valves.
2. Press **SHIFT/RESET** until “CLR” appears in the display.
3. Press **HOLD/CONT** to start the system oil separator clearing process. During the system oil separator clearing process, the compressor is activated and the “OIL” message displays.

The compressor will stop while the unit equalizes pressure and the “OIL” message will continue to display. When the unit reaches the correct pressure, the display alternately flashes the messages “OIL” and “drn.”

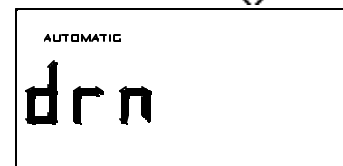
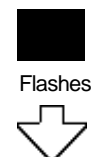
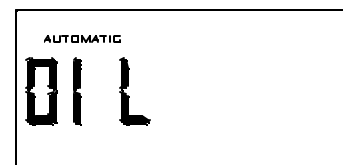
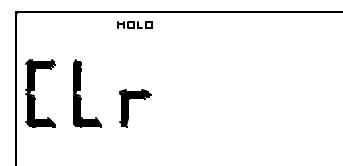

INST0240

Operating Instructions

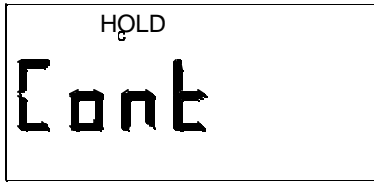

INST0241

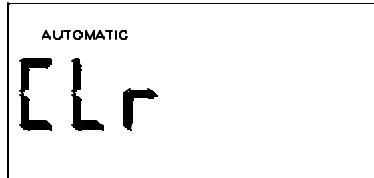

INST0300

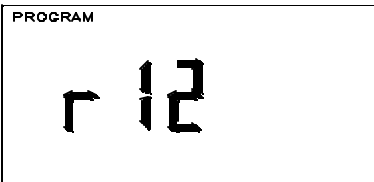

INST0288

4. Open the oil drain valve to drain the oil. After all oil has drained, close the oil drain valve. The message changes to "Cont."
5. Press HOLD/CONT to start the self-clearing process. The display will show "CLr." This will take approximately 12 minutes.
6. When this process is complete, the display will flash PROGRAM and R-12 or R-134a (depending on the selector switch position.)
7. The refrigerant selector switch may be changed at this time. To choose a refrigerant, press ENTER.

The unit may be turned off and a refrigerant type selected when the unit is again turned on.

RECOVERING REFRIGERANT

⚠ WARNING ⚠

Some R-12 automotive fuel systems use a 1/4 inch male SAE flare access fitting. Connecting your air conditioning service or recovery/recycling equipment to this fitting can result in cross-contamination of either the fuel system or the air conditioning service equipment. These conditions can be potentially dangerous due to the flammable characteristics of gasoline. Always refer to your vehicle manual prior to connection.

CAUTION! R-134a systems have special fittings (per SAE specifications) to avoid cross-contamination with R-12 systems. Do not attempt to adapt this unit for any other refrigerant — system failure will result! Read and follow all warnings given at the beginning of this manual.

Before beginning recovery be sure your unit is set up as shown. Check for refrigerant in the tank and vacuum pump oil in the vacuum pump. (See the “Set Up Instructions.”)

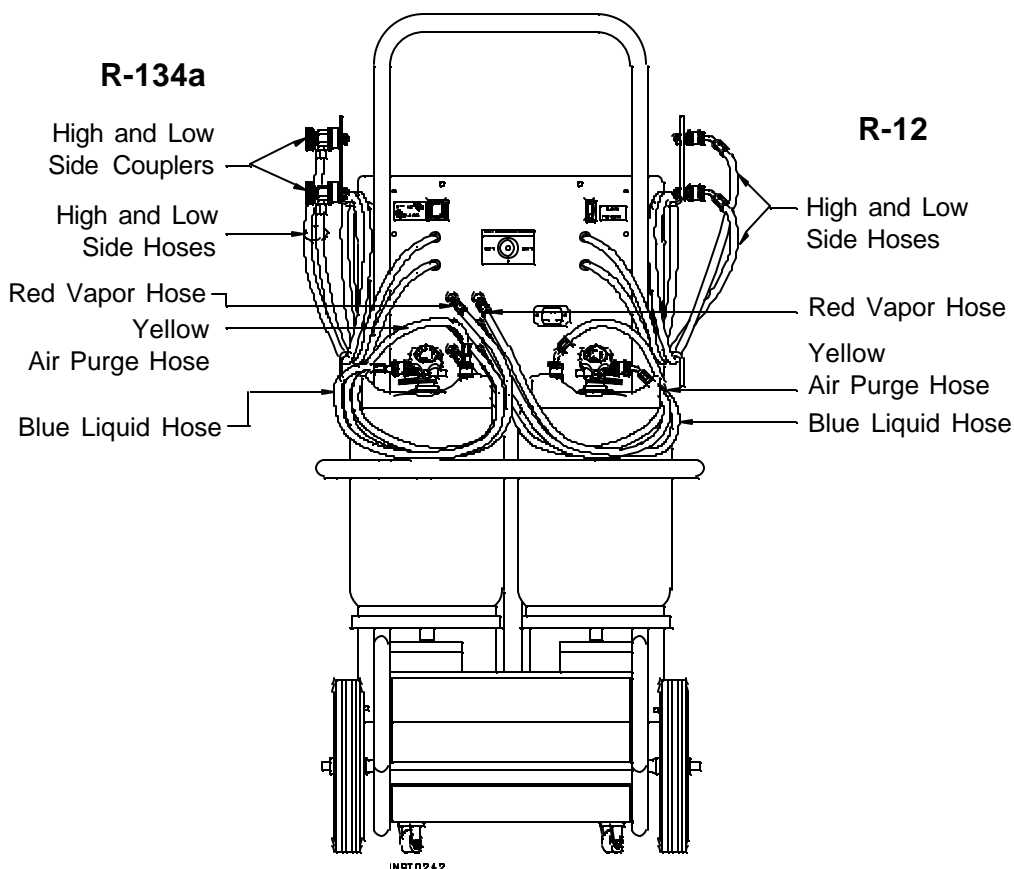

Diagram of Hose Connections

Operating Instructions

IMPORTANT!
Run the A/C system for a few minutes before starting the recovery process. Tests show more refrigerant is recovered if this action is taken. Turn the system off before proceeding.

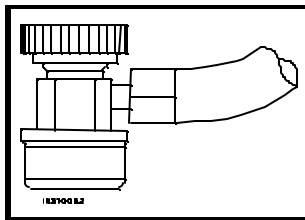

Diagram of Quick Coupler

1. Connect the hoses to the vehicle as follows:

For R-12 Systems:

- Attach the proper adapters to the low side and high side fittings on the vehicle. (An adapter package comes with each unit.)
- Connect the unit's 96 inch (244 cm) red high side hose to the adapter attached to the vehicle's high side fitting.
- Connect the unit's 96 inch (244 cm) blue low side hose to the adapter attached to the vehicle's low side fitting.

For R-134a Systems:

- Connect the unit's 96 inch (244 cm) red high side hose with the quick coupler to the high side fitting of the A/C system, then open the coupler valve.
- Connect the unit's 96 inch (244 cm) blue low side hose with the quick coupler to the low side fitting of the A/C system, then open the coupler valve.

2. Check the manifold gauges on the unit's control panel — they should both register above zero. If there is no system pressure, there is no refrigerant in the system to recover or the hoses are not connected properly.
3. Be sure the oil drain valve is closed.
4. Open both manifold valves on the control panel.

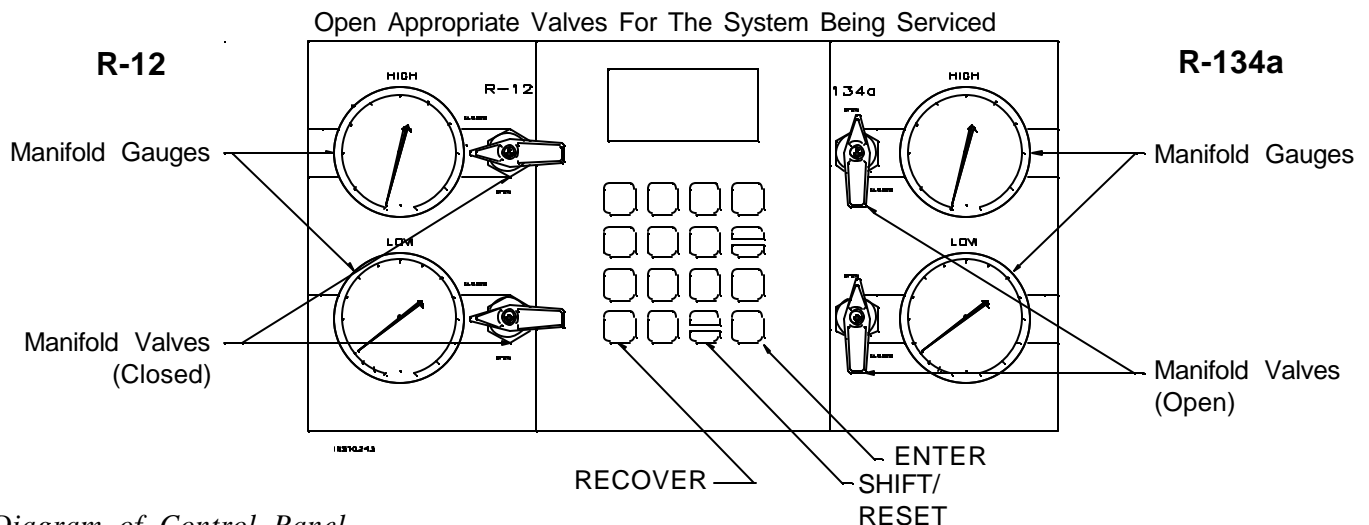

Diagram of Control Panel

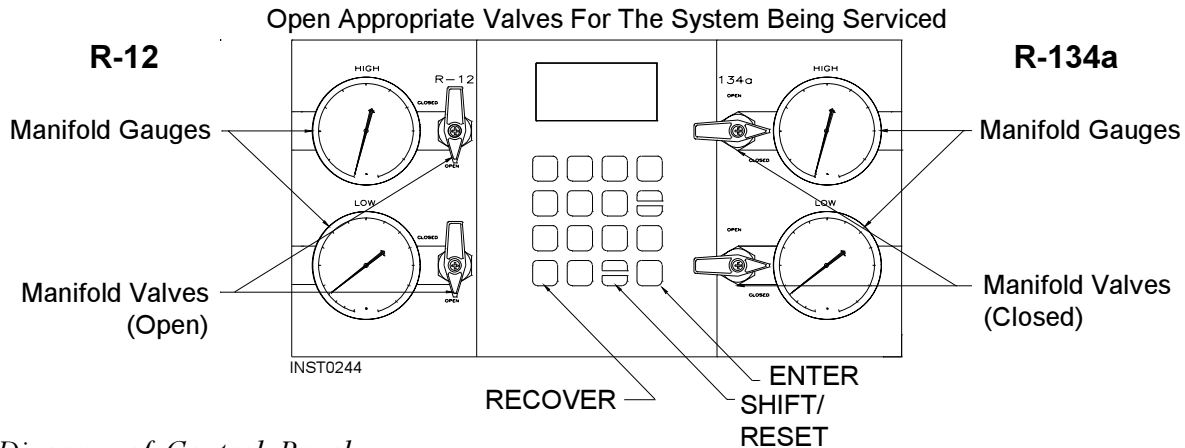
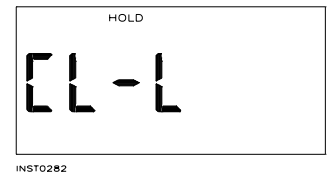

Diagram of Control Panel

5. Open the GAS (vapor) and the LIQUID valves on the tank.
6. Plug the unit into the proper voltage outlet, and turn on the **MAIN POWER** switch on the back of the unit. The display shows “R12” or “134a” to indicate the current mode.
7. Press **SHIFT/RESET**, then press **RECOVER**.

“CL-L” shows on the display if there is pressure in the unit, and a self-clearing process of the components begins. You’ll know this is occurring because the compressor will start and the “CL-L” message remains on the display. This process takes from 20 seconds to 4 minutes to complete. Once the clearing is complete, the unit automatically begins to recover refrigerant from the system.



If there is no internal pressure in the unit, refrigerant recovery begins immediately.

CAUTION! If the A/C system pressure is 25 psi or less, the message “CH-P” appears on the display to alert you not to attempt recovery from an empty system. Do not press HOLD/CONT to continue the recovery process unless you know the A/C system contains refrigerant. To exit the "CH-P" message and continue with recovery, press HOLD/CONT, or move to the PROGRAM menu by pressing SHIFT/RESET.

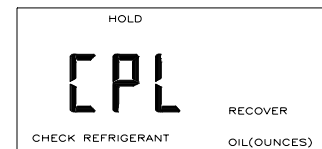
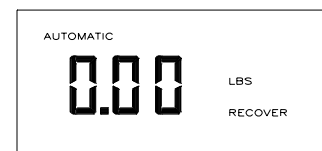

The display shows that the unit is in the RECOVER mode and the AUTOMATIC cycle. You can monitor the amount of refrigerant removed from the system by watching the display. The compressor shuts off automatically when recovery is complete (in a partial vacuum). The display shows the “CPL” message and then alternately flashes the weight of refrigerant recovered and the “OIL” message.



- To assure complete recovery of refrigerant, wait for 5 minutes and watch the manifold gauges for a rise in pressure above "0." If a rise occurs, press **HOLD/CONT**. Repeat as needed until the system pressure holds for 2 minutes.

CAUTION! Drain the oil from the separator only after each recovery. Do not completely depressurize the oil separator; immediately close the valve when oil is completely drained in the next step. The display will indicate "OIL (OUNCES)" as a reminder.

- Be sure the oil catch bottle is empty, then *slowly* open the oil drain valve, and drain the oil into the oil catch bottle. This oil was removed from the A/C system during recovery. When all the recovered oil has completely drained, immediately close the valve and record the amount of oil in the bottle.

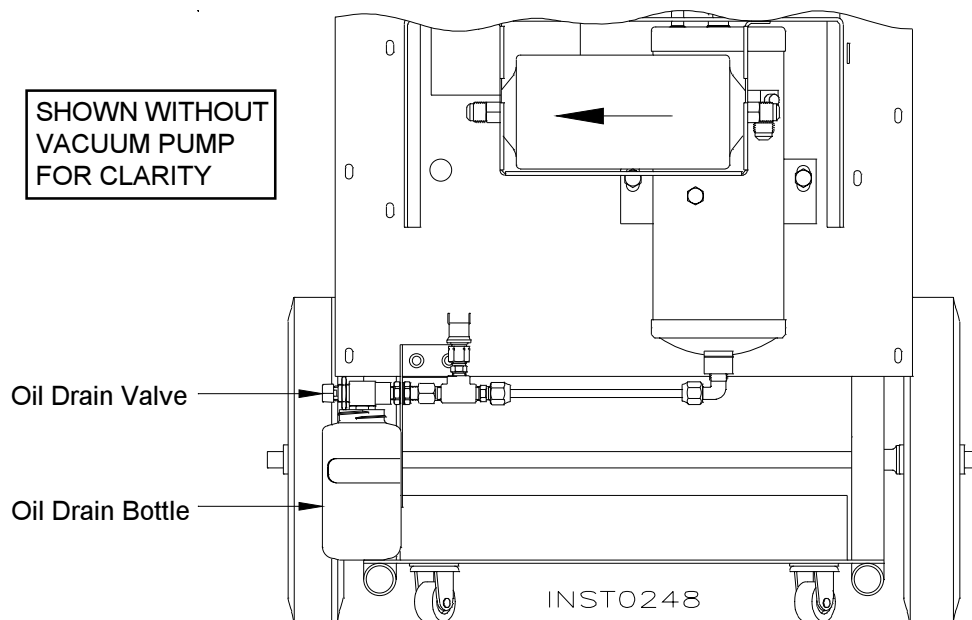
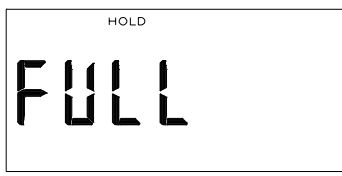

Diagram of Oil Drain Valve and Bottle



If the recovery tank fills completely:

- The compressor shuts off and the digital display flashes between "FULL" and "ADD REFRIGERANT."
- Change the tank (see "Adding Refrigerant to the Tank")

The A/C system is now empty. Make any repairs at this time.

EVACUATING THE A/C SYSTEM



WARNING



Always wear safety goggles when working with refrigerant. Use only authorized refillable refrigerant tanks. Read and follow all warnings at the beginning of this manual before operating the unit.

This station is UL-certified as a single-pass unit. During evacuation, refrigerant is *automatically* recycled to assure recharging with the cleanest possible refrigerant in no additional time.

Open Appropriate Valves For The System Being Serviced

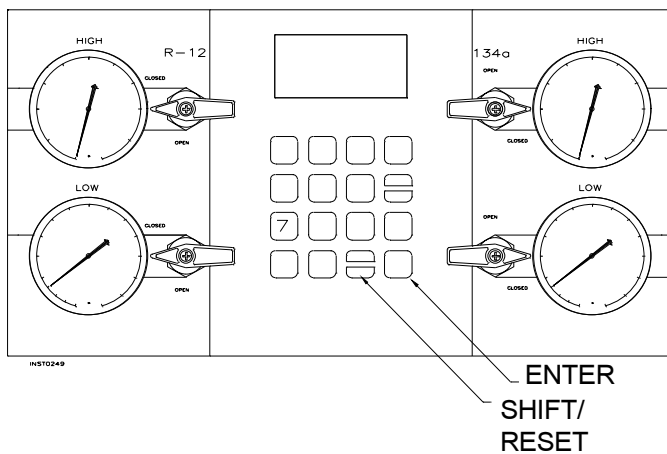

Diagram of Control Panel For R-12 Or R-134a

CAUTION! To be sure the unit tank has sufficient refrigerant for recharging, press **SHIFT/RESET** once to access the **PROGRAM** mode, then press **SHIFT/RESET** and **ENTER** at the same time to enter the diagnostic mode. Then press “7.” The display must show 5 pounds or more. About eight pounds of refrigerant is required to assure a complete A/C system charge. If the amount displayed is less than 5 pounds, add new refrigerant to the tank following the instructions in “Adding Refrigerant to the Tank.”

1. With the 96 inch (244 cm) high side and low side hoses connected to the A/C system, open both manifold valves on the control panel.
2. Open both the GAS (vapor) valve and the LIQUID valve on the tank.
3. To program the length of evacuation time, press **SHIFT/RESET**. The display shows that the unit is in the VACUUM mode.

IMPORTANT!
You should evacuate for at least 15 minutes for adequate moisture and contaminant removal.

Open Appropriate Valves For The System Being Serviced

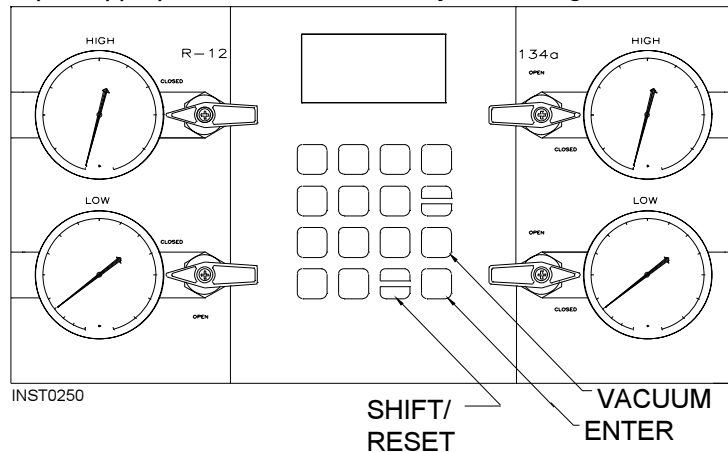
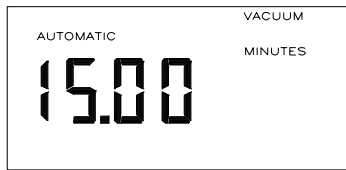

Diagram of Control Panel For R-12 Or R-134a



INST0283

- A default vacuum time of 15 minutes is preprogrammed to appear on the digital display at start-up. If required, you can override this default setting by entering a different length of time in *both minutes and seconds*. Enter the required time by pressing the appropriate number keys, then press **ENTER**. The display shows the time in minutes.

- Press **VACUUM** to start the vacuum pump. If the message “U-HI” appears you have 25 psi or greater of pressure at the inlet. You must recover that pressure to continue. If necessary, press **RECOVER**.

The digital display counts down the remaining evacuation time in minutes and seconds. Recycling begins automatically five (5) seconds after the vacuum pump starts, and the “RECYCLE” message illuminates to indicate the unit is recycling refrigerant. Non-condensable gases (mostly air) are automatically vented from the tank during the recycling process, sometimes producing an audible pressure release (a hissing sound). This is a normal function.

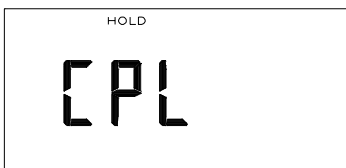
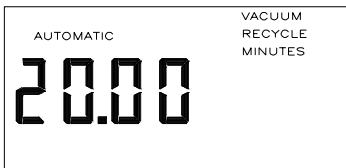

INST0284

- The vacuum sequence continues for the programmed length of time, then displays the “CPL” message to indicate that evacuation is complete.

If the moisture indicator is green, you may recharge with this refrigerant. If the moisture indicator has not turned green when the evacuation time is complete, you may need to manually recycle an entire tank (takes about 30 minutes) to get an accurate reading. If the moisture indicator still does not turn green, the filter-drier is probably saturated with moisture and should be changed, as described in “Replacing the Filter-Drier.”

- Pressing **SHIFT/RESET** 2 times at this point moves you to the charging process.

Option A

You can *recycle refrigerant only* (without pulling a vacuum) for an indefinite period of time by pressing **SHIFT/RESET** and **RECYCLE** at the same time. To cancel this operation, again press **SHIFT/RESET**.

Option B

If you require *vacuum only*, press **SHIFT/RESET** and **ENTER** at the same time, then press "1." Run the vacuum pump as long as required, then press **SHIFT/RESET** to cancel.

REPLENISHING A/C SYSTEM OIL

Before charging the A/C system, you must replenish any oil removed from the A/C system during the recovery process. Two oil injectors are supplied with this unit: one for R-12 systems with mineral oil and one for R-134a systems with PAG oil.

- Fill the oil bottle with the correct oil for the A/C system being serviced (refer to the system manufacturer's service manual).

CAUTION! To prevent air from entering the A/C system, never let the oil level drop below the pick up tube while charging or replenishing.

- Adjust the O-ring around the oil bottle to the required oil charge level. For example, if the bottle's oil level is at 4 ounces and you need only 1/2 ounce of oil to replenish the A/C system, place the O-ring at the 3½ ounce level.

CAUTION! Never open the oil injection valve while there is positive pressure in the A/C system. This could blow oil back through the bottle vent.

- Close the low side manifold valve.
- Slightly open the oil injection valve at the top of the bottle, and watch the level of oil being drawn into the A/C system.

Note: Oil charging takes only a few seconds and the valve doesn't need to be completely open.

IMPORTANT!

If the vacuum pump has run for 10 or more hours without an oil change, the message "OIL" flashes on the display. Change the pump oil following the procedures in the "Maintenance Instructions."

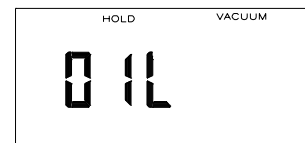

INST0253

IMPORTANT!

Keep the oil bottles tightly capped at all times to keep out moisture and contamination.

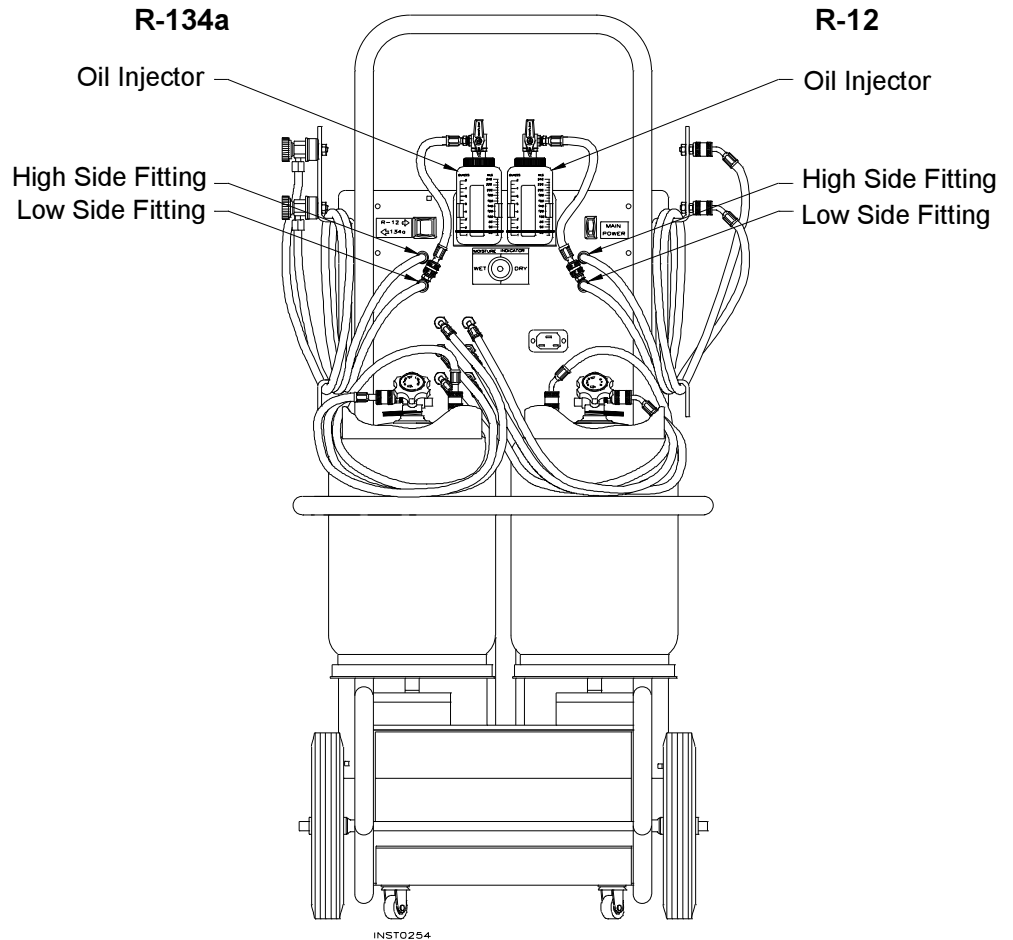

Diagram of Oil Injection System

5. Close the valve when the required oil charge has been pulled into the system.
6. Open the low side manifold valve.

RECHARGING THE A/C SYSTEM

IMPORTANT!

The unit is designed for charging through both the low side and high side. For special charging requirements, refer to the manufacturer's specifications.



WARNING



Always wear safety goggles when working with refrigerant. Use only authorized refillable refrigerant tanks. Disconnect hoses with extreme caution! All hoses may contain refrigerant under pressure. Read and follow all warnings at the beginning of this manual before operating the unit.

The A/C system must be evacuated before recharging. When you turn on the unit, you can enter the amount of refrigerant to be recharged. The unit stores this value in memory until you turn it off or program a different amount.

1. Open both manifold valves on the control panel.
2. Be sure both valves on the tank are open.
3. Enter the amount of refrigerant required to recharge the system by pressing the appropriate number keys. The charge must be entered in hundredths of a pound — the same way the nameplate on the vehicle's A/C system specifies the charge.
4. Press **ENTER**.
5. To access the CHARGE mode, press **CHG**. If this does not bring up the digital display showing "PROGRAM" and "CHARGE", press **SHIFT/RESET** to scroll through the display menu.
6. Close both manifold valves.

IMPORTANT!

Do not lean or place your hands/feet on the tank or scale during the refrigerant transfer process. Any weight disturbance will cause an incorrect transfer.

CAUTION! Be sure both manifold valves are closed before starting the A/C system.



Weight Example*

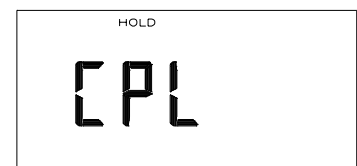

* Enter the correct weight for your application.

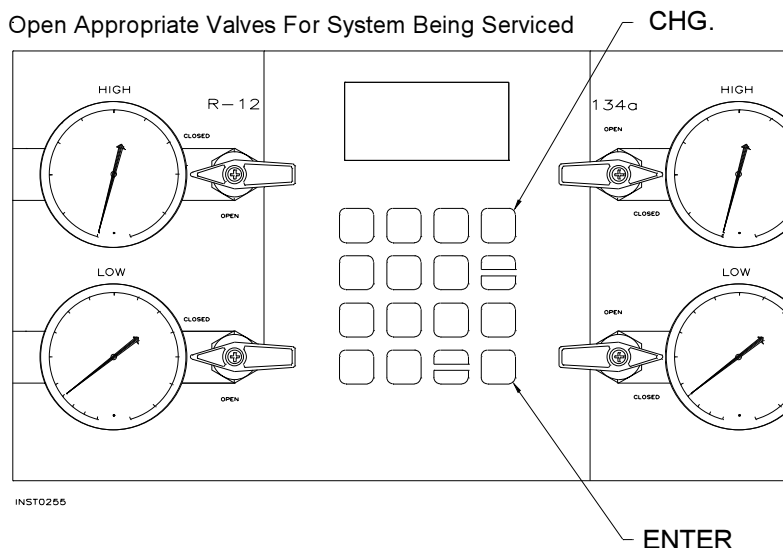

Diagram of Control Panel

⚠ WARNING ⚠

Before starting the vehicle's engine, check to see that it is in PARK or NEUTRAL with the emergency brake on. Never run a vehicle without adequate ventilation.

7. Start the vehicle's A/C system, and let it run until the gauge pressure readings stabilize (compare the gauge readings with the system manufacturer's specifications).
8. Check the evaporator outlet temperature to be sure that the A/C system is operating properly (refer to the system manufacturer's specifications for the proper temperature).
9. Turn off the vehicle's engine.
10. When using R-12, disconnect the 96 inch (244 cm) red high side hose from the high side adapter. When using R-134a, close the high side coupler valve, then disconnect the 96 inch (244 cm) red high side hose from the A/C system.
11. Restart the vehicle, then open both manifold valves on the control panel. Refrigerant from both hoses will be drawn quickly into the A/C system through the blue low side hose.
12. When both gauges show the lowest operating pressure recommended by the manufacturer, close the low side valve and turn off the vehicle's engine.
13. When using R-12, disconnect the 96 inch (244 cm) blue low side hose from the low side adapter. When using R-134a, close the low side coupler valve and disconnect the 96 inch (244 cm) blue low side hose from the A/C system.
14. Close the high side manifold valve. Both valves should now be closed. Turn off the **MAIN POWER** switch on the back of the unit.
15. When using R-12, remove the adapters from the vehicle's A/C system by pushing down on the coupler while unscrewing the fitting.

IMPORTANT!
If the message "ADD" appears, there is not sufficient refrigerant in the tank. Follow the instructions in "Adding Refrigerant to the Tank."



INST0257

CORRECTING AN INCOMPLETE CHARGE

On rare occasions you may find that the total charge does not transfer to the A/C system. There are two reasons why this can occur:

IMPORTANT!
For maximum charging accuracy, you must clear the hoses of all refrigerant.

1. The refrigerant transfer is too slow because the pressure in the unit tank and in the A/C system is equal. When this happens, the unit emits an audible signal and the display shows the weight of refrigerant remaining to be transferred. To pull the remainder of the charge into the A/C system, you should:
 - Close the high side valve.
 - Open the low side valve.
 - Start the A/C system and press **HOLD/CONT**. The remaining charge is pulled into the system and the display shows the “CPL” message.
2. The transfer will not complete and the display shows the “CHECK REFRIGERANT” message because there is not enough refrigerant in the tank to complete the process. You must then recover the partial refrigerant charge in the A/C system, add refrigerant to the tank and complete another evacuation and charge procedure:
 - Press **SHIFT/RESET** to reset the unit.
 - Recover the refrigerant that was charged into the A/C system, following the instructions in “Recovering Refrigerant.”
 - Add refrigerant to the tank, following the instructions in “Adding Refrigerant to the Tank.”
 - Evacuate the A/C system, following the instructions in “Evacuating the A/C System and Recycling Refrigerant.”
 - Recharge the A/C system.

The vehicle now has a complete charge.

This overview is designed as a quick reference when using your unit. Read and follow all warnings in the manual.

RECOVERY

1. Connect the hoses to the vehicle: red to high side port, blue to low side port.
 - When using the unit with R-12 systems, connect the red and yellow adapters to the vehicle ports first, then connect the hoses.
 - When using the unit with R-134a systems, open the quick coupler valves on the hoses after they are connected.
2. Check the manifold gauges. There must be pressure to recover refrigerant.
3. Open both manifold valves.
4. Open both tank valves.
5. Plug in the power cord, then turn on the **MAIN POWER** switch.
6. When the unit displays the selected refrigerant type, press **SHIFT/RESET**.
7. Press **RECOVER**.
 - The unit will clear itself of refrigerant and automatically start the recovery process.
 - The unit is now in the RECOVER mode of the AUTOMATIC cycle. The weight of refrigerant is displayed as it is recovered.
 - The unit will automatically shut off when recovery is complete.
 - The unit will also display the amount of refrigerant recovered.
8. Wait 5 minutes; watch the gauges. If there is no rise in pressure, recovery is complete. If a rise in pressure occurs, press **HOLD/CONT** and repeat until pressure holds for 2 minutes.
9. Drain the oil separator by opening the oil drain valve, then measure and record the amount of oil drained – it must be replaced with new oil during charging.

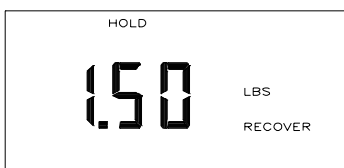
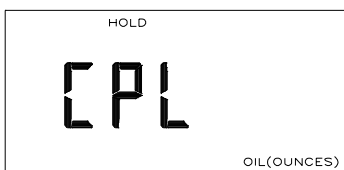
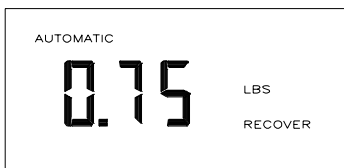
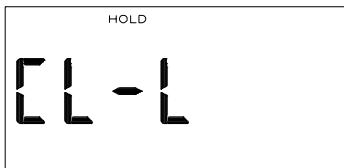

INST0286

EVACUATION

1. Be sure both manifold valves and both tank valves are still open.
2. Press **SHIFT/RESET** until the message “PROGRAM VACUUM MINUTES” appears on the display.
3. Press **VACUUM** – The display counts down the vacuum time. Recycling is automatic while the system is evacuated.

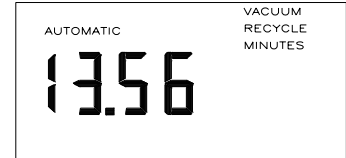

NOTE: To run an untimed vacuum, enter 99.00 minutes, press **ENTER**. Then press "VACUUM". The display will show "CON" for continuous, and will run until you press **HOLD/CONT**.

4. The unit displays the “CPL” message when evacuation is complete.
5. Check the moisture indicator. If it is green, you are ready to recharge. If it is not green, you can recycle manually by pressing **SHIFT/RESET** and “1” at the same time. Allow the unit to recycle for at least one hour. If the moisture indicator still does not turn green, replace the filter-drier.
6. Add oil to the A/C system using the oil injector.
7. Press **CHG** to move to the recharging function.

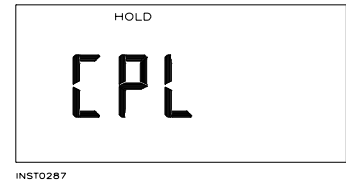

INST0287

IMPORTANT!
The unit is designed for charging through both the low side and high side. For special charging requirements, see the manufacturers specifications.

RECHARGING

1. Be sure both manifold valves are open.
2. Be sure both tank valves are open.
3. Enter the refrigerant charge by weight in hundredths of a pound.
4. Press **ENTER**, then press **CHG**.
5. The display counts down to 0, then shows “CPL” when complete.

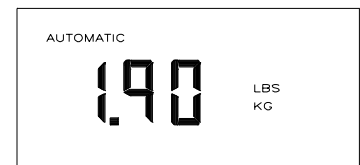
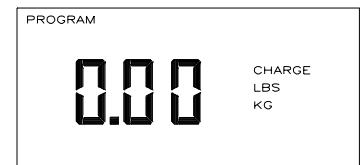

Weight Example*

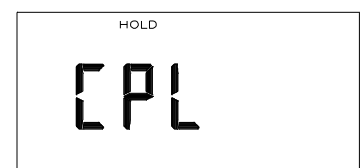

INST0288

*Enter the correct weight for your application.

6. Close both manifold valves and start the vehicle. Set the vehicle's A/C system for maximum cooling. Check the gauges and the temperature in the vehicle.
7. Turn off the vehicle's engine.
8. Disconnect the high side hose and start the vehicle. Open both manifold valves to pull refrigerant from the hoses.
9. At the lowest recommended operating pressure, close the low side valve and turn off the vehicle. Disconnect the low side hose and remove the adapters, if used.
10. Close the high side manifold valve. Both valves should now be closed. Turn off the **MAIN POWER** switch.

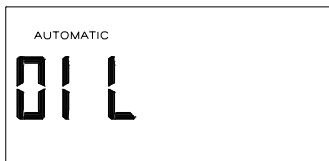
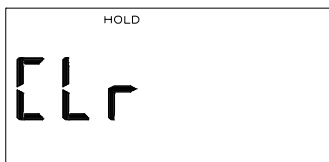

Flashes



INST0240



INST0241

CHANGING REFRIGERANT TYPES

Follow these steps to change the designated refrigerant type to either R-12 or R-134a and to prevent mixing of R-12 and R-134a.

1. Disconnect the red high side and blue low side hoses from the A/C system, then open the manifold and tank valves.
2. Press **SHIFT/RESET** until "CLR" appears in the display.
3. Press **HOLD/CONT** to start the system oil separator clearing process. During the system oil separator clearing process, the compressor is activated and the "OIL" message displays.

The compressor will stop while the unit equalizes pressure and the "OIL" message will continue to display. When the unit reaches the correct pressure, the display alternately flashes the messages "OIL" and "drn."

4. Open the oil drain valve to drain the oil. After all oil has drained, close the oil drain valve. The message changes to "Cont."
5. Press **HOLD/CONT** to start the self-clearing process. When this process is complete, the display will flash the current selected refrigerant type. The refrigerant type may be changed at this time.

The unit may be turned off and a new refrigerant type selected when the unit is turned on again.

There are just a few routine maintenance procedures necessary to keep your unit operating properly.

REPLACING THE FILTER-DRIER

The filter-drier on this unit is designed to trap acid and particulates and is formulated to remove the high moisture content of refrigerant. If the moisture indicator doesn't change from yellow to green, you must change the filter-drier to assure adequate moisture and contaminant removal.

Typically, you can recycle up to 300 pounds of refrigerant between filter changes. To help you know when you've reached that point, the unit displays the "CH-F" warning message, prompting you to change the filter-drier.

The "CH-F" message will also display since it is based on the total weight of refrigerant recovered. When this happens, you can bypass the filter replacement routine and finish recovering refrigerant. However, it is important that you change the filter-drier before evacuating the system.

- *To bypass the filter replacement routine:*

1. Press **HOLD/CONT**, and resume operation. When recovery is complete, follow the filter replacement routine in this section.

- *To start the filter replacement routine:*

1. If the manifold valves are open, close both of them.
2. If you have just completed recovery, go to Step 3.

If *automatic* vacuum/recycling is in process, press **HOLD/CONT** to interrupt the cycle, then press **SHIFT/RESET**.

If *manual* recycling is in process, press **SHIFT/RESET** to interrupt the cycle.

3. Press **SHIFT/RESET** and **FILTER** at the same time to recover all the remaining refrigerant from the low side of the unit. The display shows the messages "FIL," "AUTOMATIC" and "RECOVER." When all of the refrigerant has been removed, the messages change to "FIL" and "HOLD" to indicate the unit is waiting for the filter replacement.

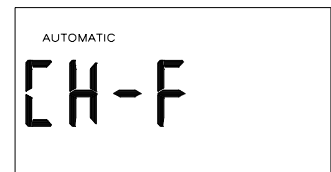

INST0289

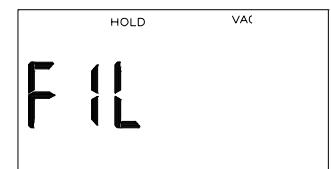
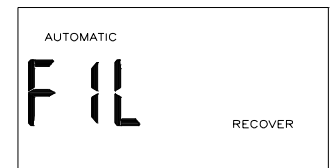

INST0263

Maintenance Instructions

- When all of the refrigerant has been recovered, remove the access door. Then remove the filter-drier by unscrewing the nuts located at each end of the filter-drier. Dispose of the used filter-drier properly. Inspect the condition of the gaskets inside the copper tubes connected to the filter. Replace if necessary (part no. 40084).
- Remove the caps from each end of the filter-drier, then install the new filter-drier and hand-tighten the nuts. (Note: If the filter-drier nuts are too tight, the gaskets may restrict the flow of refrigerant.) Be sure the refrigerant flow arrow points to the left.

IMPORTANT!
Do not remove the caps from the filter ends until you are ready to install it in the unit.

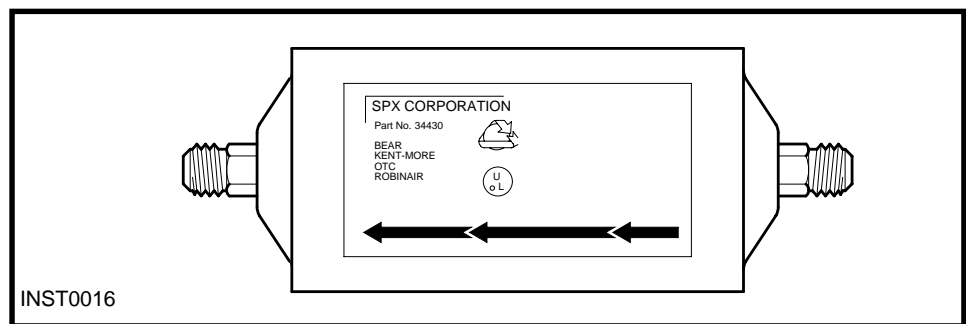

CAUTION! For best results, use filter-drier, part no. 34430. All performance tests and claims are based on using this specially blended filter-drier. Use of another type may affect performance results.



INST0264

- Press **HOLD/CONT**. The vacuum pump starts automatically and runs for five minutes before shutting off. The messages on the digital display change to "FIL" and "VACUUM."

Diagram of Filter-Drier

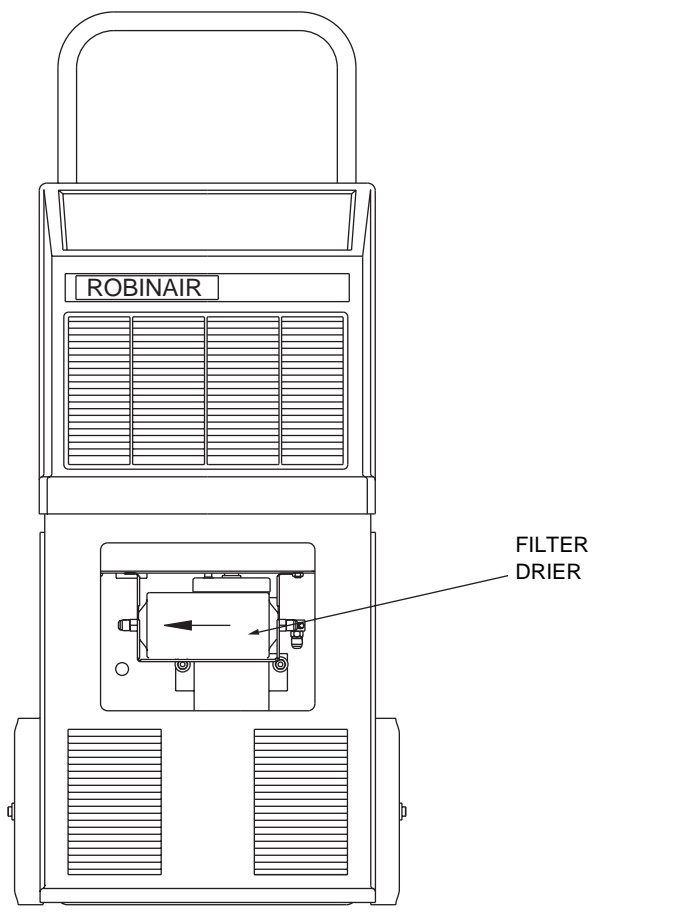

INST0082

IMPORTANT!
Be sure the refrigerant flow arrow on the new filter-drier points to the left as shown in the drawing.

Diagram of Filter-Drier Location

- After the vacuum pump shuts off, your unit will return to the main menu.

If you had just finished recovering refrigerant from the system, go to “Evacuating the A/C System” and follow the instructions in that section.

If you were in the middle of *automatic vacuum/recycling*, press **VACUUM** to enter the automatic vacuum/recycling mode. You will have to start that process over – you cannot pick up where you left off. Follow the instructions in the “Evacuating the A/C System.”

If you were in the *manual recycling* mode, press **SHIFT/RESET** and **ENTER** at the same time. Recycle until the moisture indicator turns green, then press **SHIFT/RESET** to stop recycling.

Any air left in the unit by the filter replacement is removed by the automatic air purge during recycling.



INST0301

CHANGING THE VACUUM PUMP OIL

For maximum vacuum pump performance, change the vacuum pump oil when the “OIL” message flashes on the display (after the pump has run for 10 or more hours without an oil change).

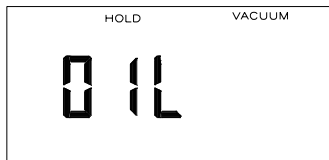

INST0265

1. Turn on the **MAIN POWER** switch. The display shows the selected refrigerant type.
2. Press **SHIFT/RESET** and the messages “PROGRAM - VACUUM - MINUTES - 15:00” display.
3. Press **VACUUM**. The display shows the “OIL” message.
4. Press **SHIFT/RESET** and **ENTER** at the same time to reset the 10-hour timer.
5. Press **VACUUM** again, and let the vacuum pump run for 5 minutes.
6. At the end of 5 minutes, press **HOLD**.
7. Remove the access door from the front of the unit.
8. Remove the black plastic plug on the oil fill port.

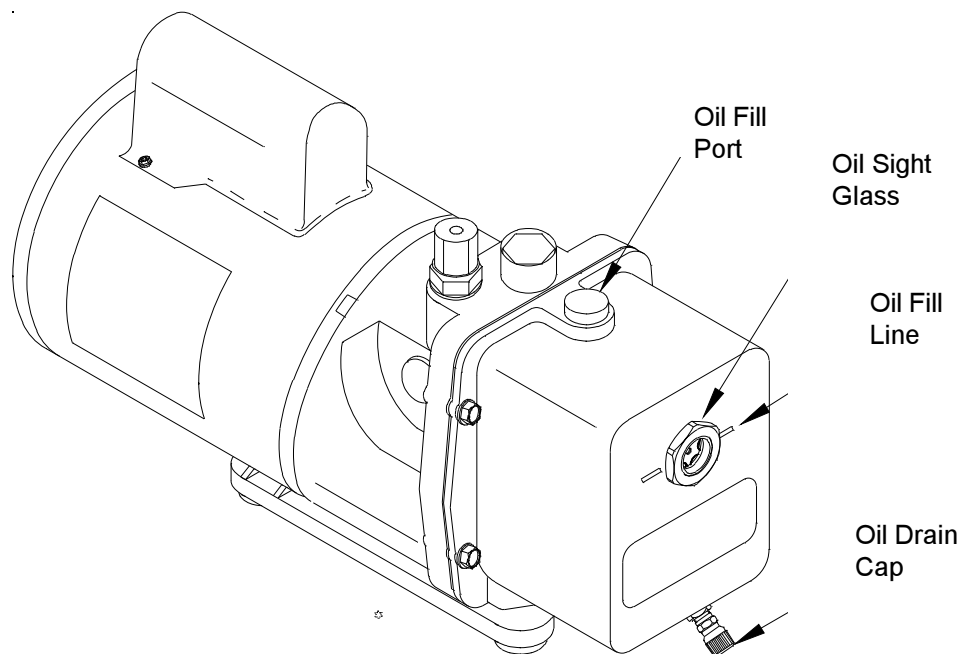

INST0067

Diagram of Vacuum Pump Components

9. Remove the oil drain cap from the vacuum pump, then drain the contaminated oil into a suitable container and dispose of it properly.
10. Replace the oil drain cap.
11. Attach the flexible spout and cap to the oil bottle and pour approximately 6 ounces of vacuum pump oil into the oil fill port.
12. Press **CONT**. While the pump is running, *slowly* add new vacuum pump oil until the oil level is even with the line on the reservoir's sight glass.
13. Replace the black plastic plug on the oil fill port.
14. Replace the access door on the front of the unit.
15. Press **VACUUM** to continue or turn off the **MAIN POWER** switch if you are finished.

CHECKING THE SCALE ACCURACY

Follow these steps to check the accuracy of the scale.

1. Turn on the **MAIN POWER** switch.
2. Press **SHIFT/RESET** until the program prompt is highlighted on the screen.

Note: If the unit is just being turned on, the screen will default to display the selected refrigerant type. Press **SHIFT/RESET** until the **PROGRAM** message is displayed.

3. When the screen has the **PROGRAM** prompt highlighted, press **SHIFT/RESET** and **ENTER** at the same time. The screen will display the message "Func" when the manual diagnostic mode has been accessed properly.

IMPORTANT!

Verify that the scale is plugged into the main board if the scale will not react to testing.

4. Remove all weight from the scale platform, then press “6” to turn the scale into a direct reading weight scale.

Note: Whatever weight is on the scale when “6” is pressed will not be shown on the display. When you press “6” the unit automatically zeros the weight on the scale. If you remove the weight, the display will show the change in total weight but will not show a negative sign.

CALIBRATING THE SCALES

If necessary, follow these steps to calibrate the scales.

1. Remove all weight from the scale platforms.
2. Plug in the unit and turn on the **MAIN POWER** switch.
3. Press **SHIFT/RESET** to access the program mode.
4. Press **SHIFT/RESET** and **ENTER** at the same time to access the diagnostics mode. The message “FUNC” will display.
5. Press **9** and the display will show a series of dashes. Then press **ENTER** and **RECOVER** at the same time. The display will flash the message “DATE” and then show “0.00.”
6. Enter the current month and year. For example, if the unit is being calibrated in November of 1996, press “1, 1, 9, 6”, then press **ENTER**. The display will flash “Zero” and “R-12.”
7. Press **ENTER** again. The display will flash “R-12,” then “A1,” then “0.00.”
8. Place a known weight on the R-12 scale platform - more than 10 lbs. and less than 80 lbs - then enter that weight numerically on the keypad. For example, to record 20 pounds on the scale, press “2, 0, 0, 0” on the keypad.
9. Press **ENTER**. The display will show “Zero” and “R-134a.”
10. Press **ENTER**. The display will flash “R-134a,” then “A1,” then “0.00.”
11. Repeat Steps 8 and 9, using the R-134a scale.

CHECKING FOR LEAKS

Every three months, or as specified by local or state laws, you should check your unit for leaks. As with any mechanical equipment general use, moving the unit and vibration can cause fittings to loosen.

1. Turn off the **MAIN POWER** switch, and disconnect the power cord from the outlet.
2. Remove the shroud by removing the 12 screws at the back of the unit.
3. Use a leak detector to probe all fitting connections for refrigerant leaks. Tighten fittings if a leak is indicated.
4. Replace the shroud.

IMPORTANT!

Inspect the unit periodically for leaks. The manufacturer of this recovery/recycling unit does not reimburse for lost refrigerant!

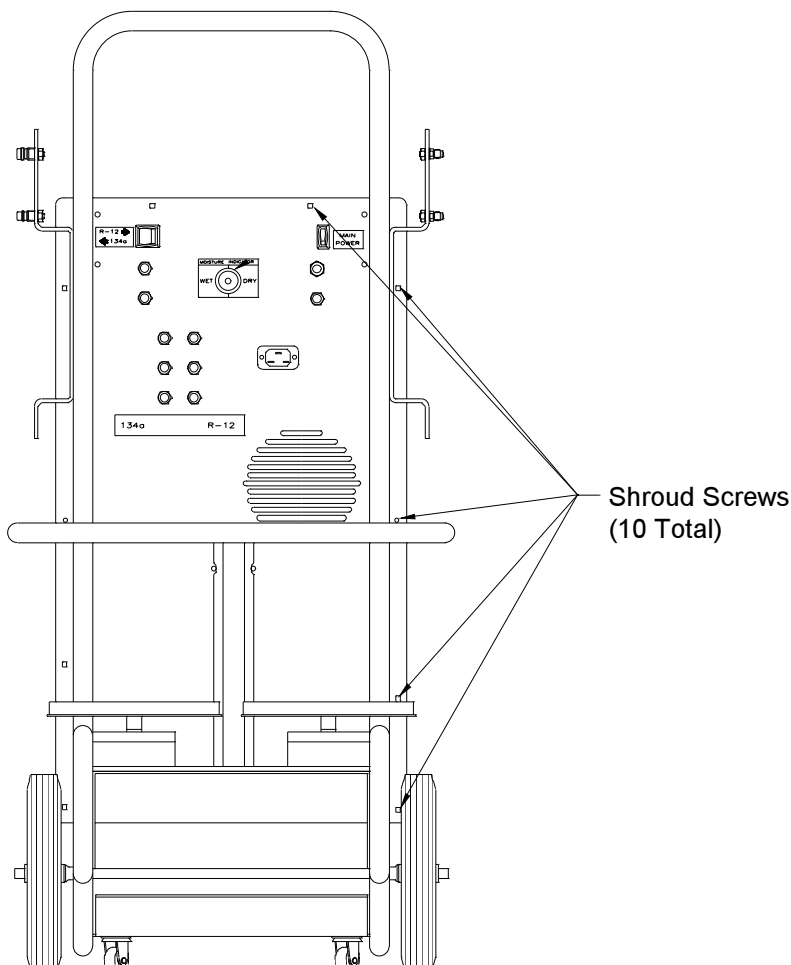

Diagram of Shroud Screw Locations

RECOVERY OPERATION

Compressor does not start or stops prematurely.

Problem: Power cord not plugged in or no power at plug.

Solution: *Check circuit for power.*

Problem: MAIN POWER switch is off.

Solution: *Turn on switch.*

Problem: “FULL” message on digital display.

Solution: *Change tanks (see “Preparing a Refrigerant Tank”).*

Problem: “HI-P” message on digital display.

Solution: *Be sure tank valves are open and hoses are properly connected to the tank, **or** check the scale calibration (see “Checking the Scale Accuracy”) **or** check the two-amp fuse on the main board.*

Problem: “CH-F” message on digital display.

Solution: *Remove and replace the filter-drier (see “Replacing the Filter-Drier”), and be sure to pull a vacuum before continuing.*

Runs a short time, but does not complete recovery.

Problem: Tank valves closed.

Solution: *Open both valves and be sure hoses are properly connected to the tank.*

Problem: Manifold valves closed.

Solution: *Open both valves.*

Problem: Adapters not in use; couplers closed.

Solution: *Install adapters; open couplers.*

Runs but won't shut off.

Problem: Oil drain valve open.

Solution: *Close the valve.*

Problem: Leak in vehicle system.

Solution: *Locate and repair all system leaks (see Maintenance Instructions).*

Problem: Hoses are not properly connected to the vehicle.

Solution: *Check hose connections.*

Problem: Adapters not in use; couplers closed.

Solution: *Install adapters; open couplers.*

For further assistance, call (800) 822-5561. Please have model number, serial number, date code, and proof of purchase.

RECYCLING OPERATION

Compressor does not start or stops prematurely.

Problem: “CH-F” message on digital display.

Solution: *Remove and replace filter-drier (see “Replacing the Filter-Drier”), and be sure to pull a vacuum before continuing.*

Problem: Tank valves closed.

Solution: *Open both valves and be sure hoses are properly connected to the tank.*

Moisture indicator will not turn green after evacuation is complete.

Problem: Wet filter-drier cartridge.

Solution: *Remove and replace filter-drier (see “Replacing the Filter-Drier”), and be sure to pull a vacuum before continuing.*

Problem: Faulty moisture indicator.

Solution: *Remove and replace the moisture indicator.*

Refrigerant does not flow.

Problem: Refrigerant supply empty or low.

Solution: *Add refrigerant to the tank.*

Problem: Tank valves closed.

Solution: *Open both valves and be sure hoses are properly connected to the tank and the unit.*

For further assistance, call (800) 822-5561. Please have model number, serial number, date code, and proof of purchase.

EVACUATION OPERATION

Vacuum pump does not start.

Problem: “U-HI” message on digital display.

Solution: *Recover all refrigerant before pulling a vacuum.*

Problem: Vacuum pump unplugged.

Solution: *Plug the pump into the vacuum pump power connector on the unit.*

Problem: Vacuum time not entered.

Solution: *Program the required time for vacuum.*

Vacuum pump runs, but low side gauge does not register an appropriate vacuum.

Problem: Pump oil contaminated.

Solution: *Flush and change the vacuum pump oil.*

Problem: Charging line loose.

Solution: *Check connections.*

Problem: Manifold leaking.

Solution: *Check connections.*

Problem: Low side valve closed.

Solution: *Open low side valve.*

Problem: $\frac{3}{8}$ ” hose improperly connected to pump.

Solution: *Check connection.*

For further assistance, call (800) 822-5561. Please have model number, serial number, date code, and proof of purchase.

RECHARGING OPERATION

No power when Main Power switch is on—no display showing.

Problem: Unit unplugged.

Solution: *Plug the unit into a power source.*

Problem: No power at wall outlet.

Solution: *Locate the problem with the outlet or change outlets.*

Audible tone sounds during refrigerant transfer.

Problem: Transfer stopped or too slow.

Solution: *Close the high side valve, then start the A/C system and pull the remaining refrigerant into system (see “Recharging the A/C System”), or be sure the blue hose has access to the tank; also be sure there are no obstructions and that the hose is properly connected.*

Problem: Refrigerant supply empty.

Solution: *Add refrigerant to the tank.*

Problem: Tank valves closed.

Solution: *Open both valves and be sure hoses are properly connected to the tank and the unit.*

Problem: LIQUID tank valve closed.

Solution: *Open the LIQUID tank valve and be sure the blue LIQUID hose is properly connected.*

Refrigerant does not flow.

Problem: Refrigerant supply empty.

Solution: *Add refrigerant to the tank.*

Problem: Tank valves closed.

Solution: *Open both valves and be sure hoses are properly connected to the tank and the unit.*

Problem: Flow restriction.

Solution: *Check all connections on the A/C system, **or** check the blue hose connection at the tank's blue valve — be sure it is getting access, **or** check the tank's blue valve — it should be open, **or** be sure the A/C system has been evacuated (vacuum pump running) for a minimum of 15 minutes of vacuum.*

For further assistance, call (800) 822-5561. Please have model number, serial number, date code, and proof of purchase.

ERROR/MESSAGE CODES

- ADD** There is less than six pounds of refrigerant in the tank. Add refrigerant to the tank. See “Adding Refrigerant to the Tank.”
- CAL** The scale is out of calibration. See “Calibrating the Scale” or call the factory at (800) 822-5561.
- CH-F** The unit has recovered the recommended maximum amount of refrigerant. Press **SHIFT/RESET** and **FILTER** at the same time, then replace the filter-drier.
- CH-P** The vehicle’s A/C system has less than 25 psi. Do **not** attempt recovery if the A/C system has no refrigerant. Check for restrictions at access fittings. Check the manifold valve positions (they should be open). To continue, press **HOLD/CONT**.
- CL-L** The bw side clearing routine is in progress. This occurs when you press **RECOVER** and can last up to four minutes.
- CLR** The unit is in the self-clearing process.
- CON** The vacuum pump will run continuously. Press **HOLD/CONT** to stop.
- CONT** This message prompts you to press any key to start the self-clearing process.
- CPL** The specified cycle function (recovery, evacuation, charging or adding refrigerant) is complete.
- FIL** The filter-drier changeout is in progress.

- FULL** The refrigerant recovery tank is full. Replace the tank.
- HI-P** The discharge pressure is above 435 psi. Check to be sure both tank valves are open.
- OIL** The vacuum pump has run for 10 hours. While the “OIL” message is displayed, press **SHIFT/RESET** and **ENTER** at the same time to reset the timer. Then change the vacuum pump oil.
- OIL/DRN** This alternating display indicates that the unit has reached the correct pressure and prompts you to open the oil drain valve to drain the oil.
- SCAL** The scale is damaged, disconnected, out of calibration or overloaded (it cannot exceed 45 pounds). Call the factory at (800) 822-5561.
- U-HI** There is positive pressure on the vacuum pump. Press **SHIFT/RESET** and then **RECOVER** to remove the pressure, then continue the evacuation procedure.
- 99LB** The maximum amount displayed during recovery is 99 pounds. Press **SHIFT/RESET** to clear the display.

For further assistance, call (800) 822-5561. Please have model number, serial number, date code, and proof of purchase.

Replacement Parts List

Following is a list of replacement parts and accessories you may need to service or maintain your unit.

The 30-pound (13.6 kilograms) refillable refrigerant tank is the only tank you should use with this unit. The unit's overfill limitation mechanism has been calibrated specifically for use with this tank, and the tank's valving is set up specifically for use with this unit.

We suggest you keep several filter-driers on hand so you will always be able to change them and complete any recycling job that is in progress.

Premium High Vacuum Pump Oil is available in handy quart containers or in convenient gallon containers:

Quart (shipped 12 quarts per case)	13203
Gallon (shipped 4 gallons per case)	13204

Tanks, filter-drier, and vacuum pumps should be purchased through your regular distributor.

**Because of ongoing product improvements,
we reserve the right to change design,
specifications, and materials without notice.**

Replacement Parts List

Component	115-Volt	220-Volt
30-Lb. (13.6 kg) Tank 134a	34130	34130
36" Red Hose Auto Shut Off	68121A	68121A
36" Blue Hose Auto Shut Off	68122A	68122A
36" Yellow Hose Auto Shut Off	68123A	68123A
96" Red Hose Auto Shut Off	68396	68396
96" Blue Hose Auto Shut Off	68296	68296
36" Acme Hose Blue	68127	68127
36" Acme Hose Red	68126	68126
36" Acme Hose Yellow	68128	68128
Acme Quick Seal Hose Red	63096	63096
Acme Quick Seal Hose Blue	62096	62096
Fan	RA17416	RA17516
Filter-Drier	34430	34430
Compressor	RA19302	RA19314
Vacuum Pump	RA15425	RA15428
Moisture Indicator	RA17577	RA17577
Solenoids — Air Purge, Clearing	RA19006	RA19088
Equalization Solenoid	RA17522	RA17578
High Pressure Switch	RA17529	RA17529
Main Power Switch	RA19343	RA19343
Vacuum Switch	RA18752	RA18752
Pump Protection Switch	RA19266	RA19266
Expansion Valve and Tube	RA19316	RA19316
Manifold	RA19320	RA19321
Oil Drain Valve	RA19291	RA19291
Oil Catch Bottle	RA17419	RA17419
Scale Assembly	RA19008	RA19210
Main Circuit Board	RA19325	RA19369
High Side Gauge	RA19280	RA19318
Low Side Gauge	RA19279	RA19319
Low Side Coupler	18190A	18190A
High Side Coupler	18191A	18191A
Vinyl Dust Cover	17495	17495
Air Purge Automatic R-12	RA19198	RA19198
Air Purge Automatic R-134a	RA19242	RA19242
Relays	RA17459	RA17324
Wheels	10751	10751
Solenoid Rebuild Kit	RA19258	RA19258
30-lb (13.6 kg) Tank R-12	17105	17105
Power Cord	RA19303	RA19294
Oil Drain Pressure Switch	RA19297	RA19297

Flow Diagram

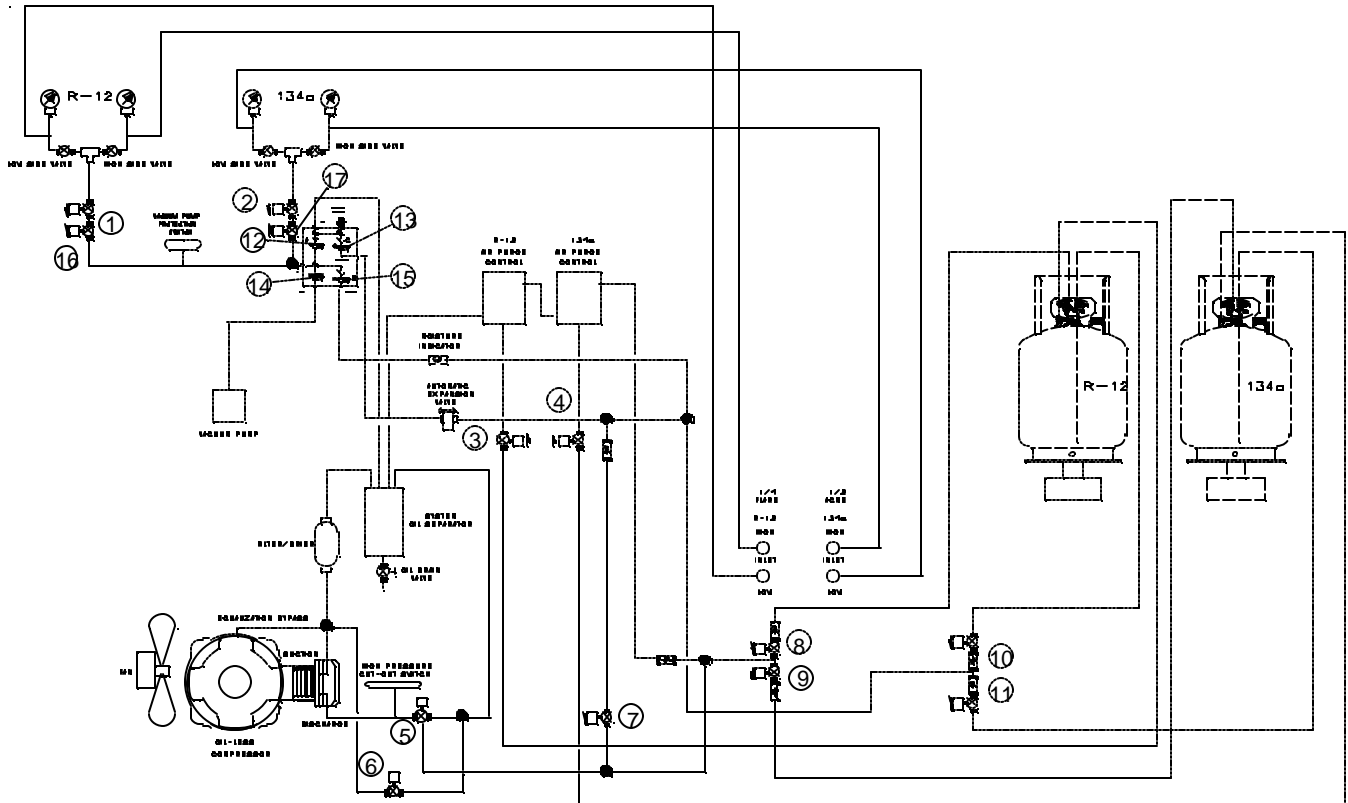

INST0268

+ TIME DELAY
 X ENERGIZED
 0 DE-ENERGIZED
 + MANIFOLD

SOLENOID	DESCRIPTION	FUNCTION									
		RECOVER		VACUUM		RECYCLE		DCHARGE		CLEANING	
		R-12	134a	R-12	134a	R-12	134a	R-12	134a	R-12	134a
TIED TO SOLENOID #15	1 R-12 INLET	X	0	X	0	0	0	X	0	X	0
TIED TO SOLENOID #17	2 134a INLET	0	X	0	X	0	0	0	X	0	X
	3 R-12 AIR PURGE	0	0	X	0	X	0	0	0	0	0
	4 134a AIR PURGE	0	0	0	X	0	X	0	0	0	0
	5 HI SI DIVERSION	0	0	0	0	0	0	0	0	X	X
	6 EQUALIZATION	X	X	X	X	X	X	0	0	0	0
	7 MAN BY-PASS	0	0	0	0	0	0	0	0	X	X
	8 R-12 VAPOR	X	0	X	0	X	0	0	0	X	0
	9 134a VAPOR	0	X	0	X	0	X	0	0	0	X
	10 R-12 LIQUID	0	0	X	0	X	0	X	0	0	0
	11 134a LIQUID	0	0	0	X	0	X	0	X	0	0
	12 + INLET VALVE	X	X	0	0	0	0	0	0	X	X
	13 + RECYCLE VALVE	0	0	X	X	X	X	0	0	X	X
	14 + VACUUM VALVE	0	0	X	X	0	0	0	0	X	X
	15 + DCHARGE VALVE	0	0	0	0	0	0	X	X	X	X
TIED TO SOLENOID #1	16 R-12 INLET BACKUP	X	0	X	0	0	0	X	0	0	0
TIED TO SOLENOID #2	17 134a INLET BACKUP	0	X	0	X	0	0	0	X	0	0

WHEN VACUUM PUMP IS ENERGIZED

INST0270

Wiring Diagram

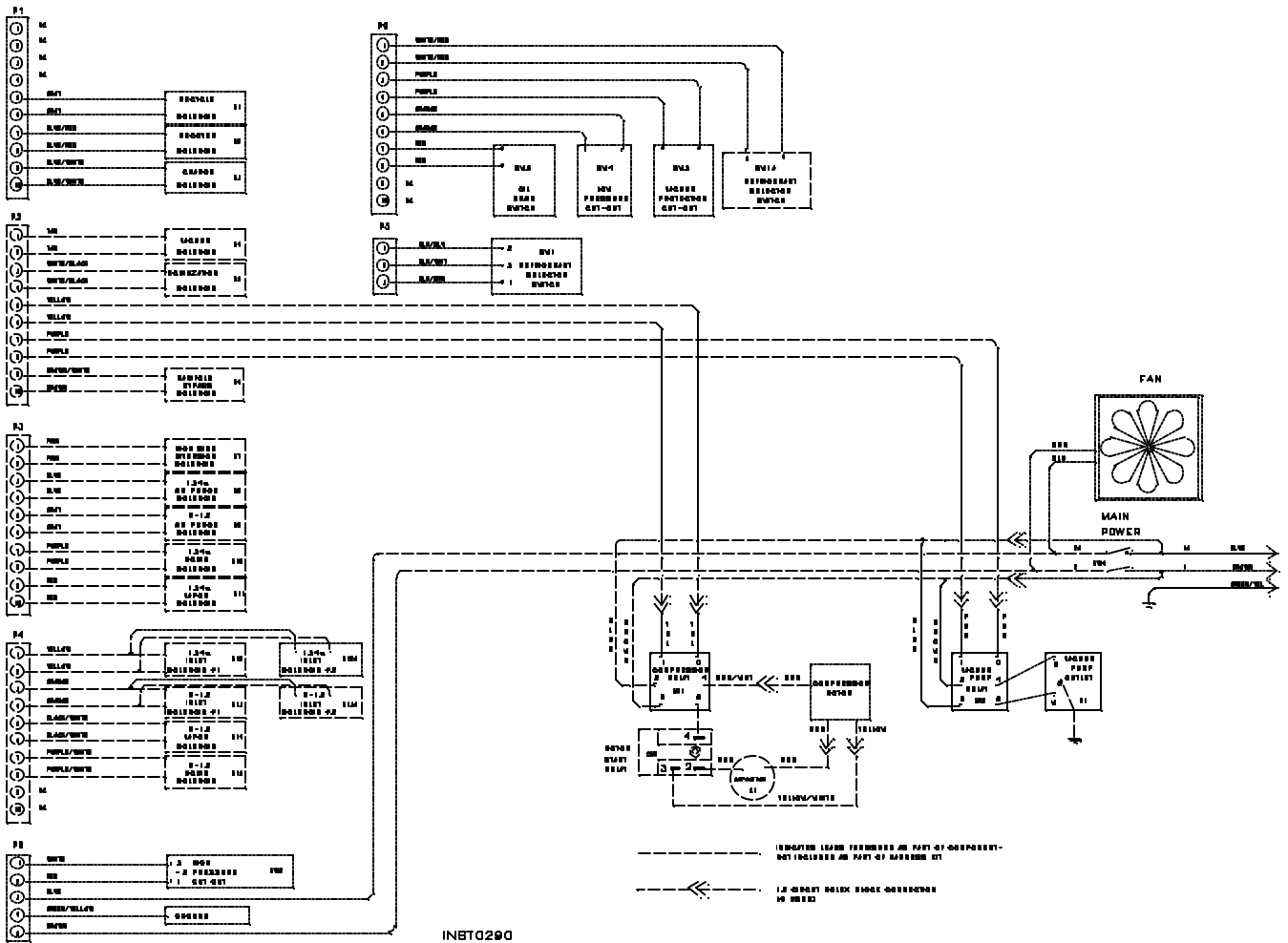

Limited Warranty

This product is warranted to be free from defects in workmanship, materials, and components for a period of one year from date of purchase. All parts and service center labor required to repair defective products covered under the warranty will be at no charge. The following restrictions apply:

1. The limited warranty applies to the original purchaser only.
2. The warranty applies to the product in normal usage situations only, as described in the Operating Manual. The product must be serviced and maintained as specified.
3. If the product fails, it will be repaired or replaced at the option of the manufacturer.
4. Warranty service is provided by our network of authorized service centers. Call the toll-free Technical Support Line, (800) 822-5561, for service authorization and the location of the nearest service center. **Do not** ship or deliver units to a service center without authorization. **Do not** ship units to the factory.
5. Warranty service claims are subject to factory inspection for product defect(s). The factory or service center personnel are the sole determinates of warranty coverage.
6. The manufacturer shall not be responsible for any additional costs associated with a product failure including, but not limited to, loss of work time, loss of refrigerant, and unauthorized shipping and/or labor charges.
7. All warranty service claims must be made within the specified warranty period. Proof-of-purchase date must be supplied to the manufacturer.
8. Use of this recovery/recycling equipment with unauthorized refrigerants will void the warranty. Authorized refrigerants are listed on the equipment or are available through our Technical Service Department.

This Limited Warranty does not apply if:

- The product, or product part, is broken by accident.
- The product is misused, tampered with, or modified.
- The product is used for recovering or recycling any substance other than the specified refrigerant type.

Note: Refillable refrigerant tanks are reusable. Do not send them to service center, unless the tank is defective.

IMPORTANT!
Please have model number, serial number, date code and proof of purchase (invoice) ready when you call for warranty authorization.

Adding Refrigerant to the Tank	17
Calibrating the Scales	42
Changing Refrigerant Types	21
Changing the Vacuum Pump Oil	40
Checking for Scale Accuracy	41
Control Panel Components	3
Correcting an Incomplete Charge	33
Digital Display Messages	4
Evacuating the A/C System	27
Installing the Tank	13
Keypad Functions	4
Manual Diagnostics	7
Operating Tips	21
Partially Filling the Tank	19
Preparing the Vacuum Pump	10
Pulling a Vacuum	13
Recharging the A/C System	30
Recovering Refrigerant	23
Replacing the Filter-Drier	37
Replenishing A/C system Oil	29
Selecting a measurement Unit	12

This equipment is protected by one or more of the following patents: U.S. Patents: 4,523,897; 4,688,388 Re 33,212; 4,768,347; 4,809,520; 4,878,356; 4,938,031; 5,005,369; 5,005,375; 5,042,271 Australian Patent: 609,240; 613,056; 622,833; 633,766; 642,085 Canadian Patents: 1,311,621; 1,311,622; 2,012,620; 2,026,348 European Patent: 315 296 B1; 329 321 B1; 437 021 B1; 443 695 B1 German Patent: 42 13 270.3 Mexican Patent: 16208 OTHER U.S. AND FOREIGN PATENTS PENDING. Mfd. by Robinair, SPX Corporation, Montpelier, OH 43543

CONVERSION TABLE

OZ.	LBS.
0.5	0.03
1.0	0.06
1.5	0.09
2.0	0.13
2.5	0.16
3.0	0.19
3.5	0.22
4.0	0.25
4.5	0.28
5.0	0.31
5.5	0.34
6.0	0.38
6.5	0.41
7.0	0.44
7.5	0.47
8.0	0.50
8.5	0.53
9.0	0.56
9.5	0.59
10.0	0.63
10.5	0.69
11.0	0.69
11.5	0.72
12.0	0.75
12.5	0.78
13.0	0.81
13.5	0.84
14.0	0.88
14.5	0.91
15.0	0.94
15.5	0.97
16.0	1 lb.



Call toll-free

Technical Support Line

800-822-5561

in the continental U.S. or Canada.

In all other locations, contact your local distributor. To help us serve you better, please be prepared to provide the model number, serial number, and date of purchase.

To validate your warranty, you must complete the warranty card attached to your unit and return it within ten days from date of purchase.

• **Nationwide Network of Authorized Service Centers**

If your unit needs repairs or replacement parts, you should contact the service center in your area. For help in locating a service center, call the toll free technical support line.

Due to ongoing product improvements,
we reserve the right to change design,
specifications and materials without notice.

ROBINAIR
SPX Corporation

1224 Robinair Way
Montpelier, OH 43543-9905 USA
Phone 419-485-5561
FAX 419-485-8300